

# HORNET

T7  
T8-RR

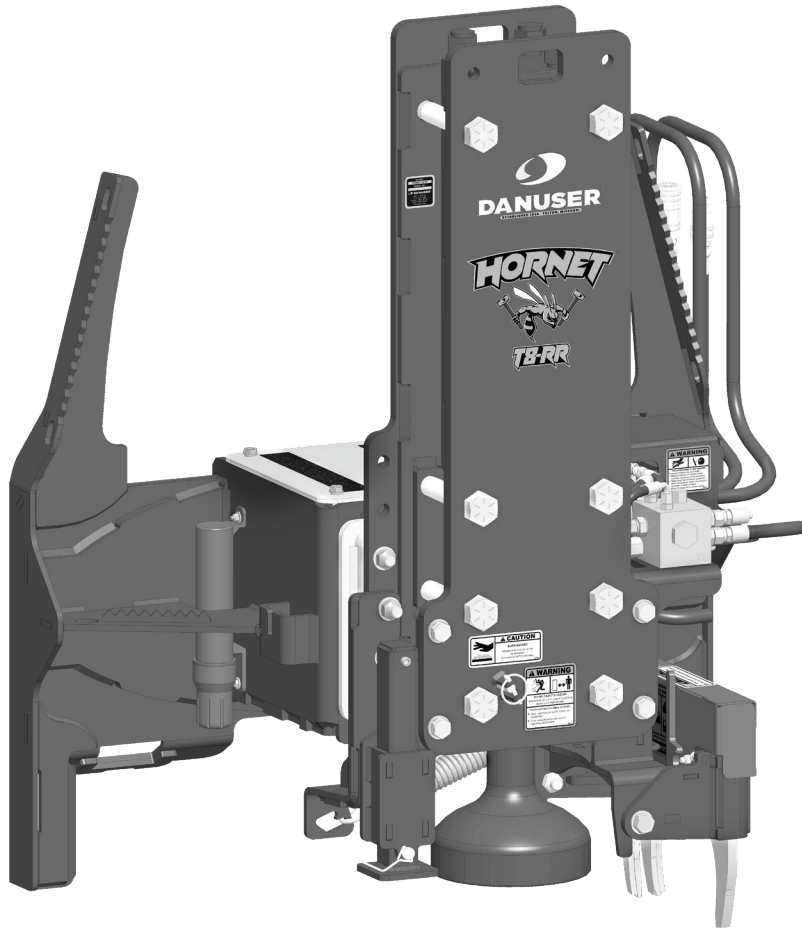

**!** Read this entire manual. This safety alert symbol is used throughout this manual to call your attention to messages involving your personal safety and the safety of others. Failure to follow these instructions can result in injury or death.

## **!** WARNING

*Si no entiende ingles, se prefiere que busque a alguien que interprete las instrucciones para usted.*

Owner: \_\_\_\_\_

Date Purchased: \_\_\_\_\_

Model #: \_\_\_\_\_ Serial #: \_\_\_\_\_

Manual #: 9MHORNETT7T82460690

## Operator's Manual

Danuser Machine Company, LLC  
500 E. 3rd St.  
P.O. Box 368

Fulton, MO 65251

Tel: (573) 642-2246

E-mail: sales@danuser.com

Website: www.danuser.com



Dear Owner/Operator,

Thank you for purchasing this Danuser Hornet. We appreciate your business.

The Hornet is designed to drive posts. With the hydraulic grapple option, one person can pick up, load, and drive posts. The tilt option allows up to a 20° tilt left or right.

Your safety as an operator of our product is very important to us. Therefore, *before* you assemble, install, operate, maintain, service, remove, or move your Danuser Hornet, read and understand this manual thoroughly. If there is anything you do not understand, immediately contact your dealer, or contact our factory direct.

Tel: (573) 642-2246  
E-mail: [sales@danuser.com](mailto:sales@danuser.com)

Your satisfaction in the performance and longevity of our product is also very important to us and can be prolonged by proper assembly, installation, operation, and maintenance as instructed in this manual.

Thank you again for your business and for your trust in our product. Please feel free to contact us at any time for further assistance.

Sincerely,

Danuser Machine Company, LLC  
500 E. 3rd St.  
P.O. Box 368  
Fulton, MO 65251

Tel: (573) 642-2246  
E-mail: [sales@danuser.com](mailto:sales@danuser.com) Website: [www.danuser.com](http://www.danuser.com)

Danuser provides this manual “as is” without warranty of any kind, either expressed or implied. Danuser assumes no responsibility for errors or omissions. Danuser assumes no liability for damages resulting from the use of the information contained herein. Danuser reserves the right to revise and improve its products as it sees fit. This manual describes the state of this product at the time of its publication and may not reflect the product in the future.

Danuser is a registered trademark.

# Foreword

*Please read this manual thoroughly!*





**Before** you assemble, install, operate, maintain, service, remove, or move your Danuser Hornet, read this manual thoroughly. If there is anything you do not understand, immediately contact your dealer, or call our factory direct at (573) 642-2246. Powered equipment can be dangerous if not assembled, installed, operated, maintained, serviced, removed, or moved properly.

### Warranty Registration

To activate your warranty coverage and to provide you with efficient customer service, please fill out your WARRANTY REGISTRATION FORM. This form is included in your unit's paperwork package. If you did not complete a WARRANTY REGISTRATION FORM or did not receive one, please call Danuser. Or, register online at [www.danuser.com](http://www.danuser.com). Your satisfaction with our product and your safety as a user of our product are both very important to us.

# Symbols

 This SAFETY ALERT symbol identifies important safety messages. Carefully read each safety message that follows. Failure to understand and obey a safety message, or recognize a safety hazard, could result in injury or death to you or others around you. The operator is ultimately responsible for the safety of himself, as well as others, in the operating area of the Hornet.

<i>Symbol</i>	<i>Meaning</i>
	Indicates an imminently hazardous situation which, if not avoided, <b>will</b> result in death or serious injury.
	Indicates a potentially hazardous situation which, if not avoided, <b>could</b> result in death or serious injury, including hazards that are exposed when guards are removed.
	Indicates a potentially hazardous situation which, if not avoided, <b>may</b> result in minor or moderate injury. It may also be used to alert against unsafe practices.
	This is important information for proper use of this equipments. Failure to comply may lead to premature equipment failure.

# Table of Contents

	Page
Letter to Owner/Operator .....	2
Foreword .....	3
Symbols .....	3
Safety .....	4
Decals & Safety Signs .....	8
Specifications .....	12
Hydraulic/ Nitrogen/ Power Cell Grease Requirements .....	16
Assembly & Installation .....	17
Operation .....	30
Removal & Storage .....	39
Troubleshooting .....	41
Maintenance & Lubrication .....	43
Service .....	46
Torque Values Chart .....	51
Parts .....	52
Accessories .....	82
Warranty .....	5003B



## Hornet

Working with unfamiliar equipment can lead to careless injuries. Read and understand this manual and the manual for your vehicle before assembling, installing, operating, maintaining, servicing, removing, or moving this Danuser Hornet. If there is anything in this manual you do not understand, contact your dealer or Danuser. The safe use of this attachment is strictly up to you, the operator. If this attachment is used, loaned, or rented by any other person, it is the owner's responsibility to make certain that the operator prior to operating:

- Reads and understands the Operator's Manual
  - Is instructed in safe and proper use
- The Hornet is designed to be operated from the vehicle seat. Keep bystanders away from the work area. Do not operate with another person in contact with any part of the Hornet.
  - All operators of this attachment must read and understand this entire manual, paying particular attention to safety messages and operation instructions, prior to assembling, installing, operating, maintaining, servicing, removing, or moving the Hornet.
  - Please remember it is also important that you read, understand, and follow safety signs on the attachment. Clean or replace all safety signs if they cannot be clearly read and understood. They are there for your safety as well as the safety of others. Danuser will furnish new safety signs upon request at no charge.
  - All things with moving parts are potentially hazardous. There is no substitute for a cautious, safe-minded operator who recognizes potential hazards and follows reasonable safety practices.
  - Personal protection equipment including hard hat, safety glasses, safety shoes, gloves, and hearing protection are recommended during assembly, installation, operation, maintenance, service, removal, or movement of the attachment.
  - Exposure to silica dust and other dust hazards can cause serious or fatal respiratory disease. Use appropriate respiratory protection.
  - When the use of hand tools is required to perform any part of assembly, installation, operation, maintenance, or service of the attachment, be sure the tools used are designed and recommended by the tool manufacturer for that specific task.
  - Never check pressurized system for leaks with your bare hand. Wear proper hand and eye protection and use wood or cardboard when searching for suspected leaks. Oil escaping from pinhole leaks under pressure can penetrate skin and create a serious medical emergency. If any fluid is injected into the skin, gangrene, blood poisoning, even death may result. Obtain medical attention immediately.
  - Always use two people to handle heavy, unwieldy components during assembly, installation, maintenance, service, removal, or movement of the attachment.
  - Never place any part of your body where it would be in danger if movement should occur during assembly, installation, operation, maintenance, service, removal, or movement of the Hornet.
  - Only properly trained people should operate this equipment. Do not allow anyone who has not read this entire manual and understands the safety rules, safety signs, and operation instructions to use this attachment.
  - Never allow children to operate or be around the Hornet.
  - Never use alcoholic beverages or drugs which can hinder alertness or coordination while operating this equipment. Consult your doctor about operating this equipment while taking prescription or over-the-counter medications.

# Safety

(continued)

- Do not allow riders on the equipment at any time. There is no safe place for any riders.
- Safe operation of equipment requires the operator's full attention. Avoid distractions such as radio headphones, cell phones, etc. while operating.
- Contact with underground gas lines or electrical cables may result in serious injury or death from explosion or electrical shock. Before operating, call 811 or the local number to locate underground utilities.
- Do not drive posts or operate near underground utility lines.
- Stay away from power lines when transporting, raising, or operating the attachment. Electrocutation can occur without direct contact.
- The Hornet must be securely latched to the vehicle. Ensure both locking handles are in the locked position with pins fully seated. An improperly latched Hornet can fall without warning.
- Before you operate the attachment, check over pins and connections to be sure all are securely in place.
- Make sure all guards are in place and secure before operating equipment.
- Keep hands, feet, hair, jewelry, and clothing away from all moving and/or rotating parts.
- Never place yourself between the vehicle and the attachment.
- Never allow anyone under the attachment at any time.
- Keep clear of the Hornet while in operation. Never position, align, or support the post by hand or with any tool when the Hornet is in operation.
- Prolonged driving of a post can generate sufficient heat to ignite combustible posts. If this occurs, stop post driving operations and immediately extinguish.
- Driving tool can become hot while operating and remain hot after shutdown. Do not touch. Allow to cool before servicing.
- Do not exceed the vehicle's rated operating load. Use sufficient counterweights. Move the vehicle slowly when the attachment is raised.
- Carry the load low. A heavy load can cause instability of the vehicle. Use extreme care during travel. Slow down on turns and watch out for bumps. Use all safety devices, including a seat belt, as recommended in the vehicle operator's manual.
- Do not operate the Hornet on steep hillsides. When operating the Hornet on uneven or hilly terrain, position the vehicle with the attachment uphill. With the attachment downhill, the vehicle could tip when attempting to raise the Hornet. Consult your vehicle operator's manual for maximum incline allowable.
- Always shut off the vehicle engine, remove the key, lower vehicle arms, and relieve all hydraulic pressure before dismounting the vehicle. Never leave equipment unattended with the vehicle running.
- Never attempt adjustments, service, or repairs while the equipment is in operation.
- Never work under equipment supported by hydraulics. Even with the vehicle shut off, equipment can suddenly drop if controls are actuated or if hydraulic lines burst.
- Before servicing or adjusting attachment, relieve all stored energy.
- Release power cell nitrogen gas pressure and hydraulic oil pressure before disassembling power cell.

## Safety

(continued)

- Before connecting or disconnecting hydraulic lines or fittings, be sure to relieve all pressure by cycling all hydraulic controls after shutdown. Remember hydraulic systems are under pressure whenever the engine is running and may hold pressure after shutdown.
- Store the attachment on a flat, level surface in an area where children do not play. Securely block and support the attachment.
- Do not modify the attachment. Modifications may weaken the integrity of the attachment and may impair the safety, function, life, and performance of the Hornet.
- When making repairs or servicing the Hornet, use only parts that meet original equipment manufacturer's standards and requirements.
- Always use care when operating the Hornet. Most accidents occur because of neglect or carelessness.

## Safety

### Nitrogen Cylinder

Nitrogen is odorless, tasteless, and nonirritating. Although it is nontoxic and largely inert, it can act as a simple asphyxiant by displacing the oxygen in air to levels below that required to support life. Inhalation of nitrogen in excessive amounts can cause dizziness, nausea, vomiting, loss of consciousness, and death. The nitrogen cylinder is a potential hazard due to the energy it contains at high pressure. Improper handling can result in a high-pressure energy release. The nitrogen cylinder should be handled only by someone familiar with the hazards of compressed gases.

- Follow all national, state, and local regulations pertaining to the storage, use, and disposal of compressed nitrogen gas.
- Personal protection equipment including safety glasses, safety shoes, and gloves is recommended when handling nitrogen cylinder.
- Do not remove product label from nitrogen cylinder.
- Nitrogen cylinder protective cap must be installed at all times when cylinder is not in use.
- Do not interchange protective caps between cylinders.
- Never lift nitrogen cylinder by its protective cap or valve.
- When moving nitrogen cylinder, never drop, drag, roll, slide, or carry nitrogen cylinder in a horizontal position as the cylinder valve may be broken off.
- Subjecting nitrogen cylinder to mechanical shocks may cause damage to valve.
- Do not use nitrogen cylinder as a roller to move material or other equipment.
- Never allow any part of the nitrogen cylinder to be exposed to temperatures exceeding 125°F.
- Never permit nitrogen cylinder to become part of an electrical circuit.
- Never strike an arc on, allow sparks to contact, or flames to contact nitrogen cylinder.
- Do not discharge the contents from the nitrogen cylinder directly towards a person.
- Never use a damaged or leaking nitrogen cylinder. If cylinder is leaking, move to a well-ventilated area if it can be done safely. Contact a qualified supplier of compressed gases for repairs.
- If the protective cap becomes stuck, use an adjustable strap wrench to loosen. Never stick anything into the protective cap holes in an attempt to loosen the cap. Doing so may result in damage to valve.

# Safety

(continued)

- Never use a wrench to open or close the nitrogen cylinder valve. If the valve is difficult to operate, discontinue use and contact a qualified supplier of compressed gases for repairs.
- Do not attempt to tighten or loosen nitrogen cylinder valve into or out of the cylinder.
- Never adjust or tamper with bonnet nut on nitrogen cylinder valve.
- The nitrogen cylinder is equipped with a pressure relief device. Do not tamper or modify this pressure relief device.
- Servicing of nitrogen cylinder pressure relief device is only to be performed by a qualified supplier of compressed gases.
- Do not obstruct nitrogen cylinder pressure relief device. Dirt, paint, corrosion, or other materials can prevent device from functioning properly.
- Always close nitrogen cylinder valve completely and install protective cap when not in use.
- Secure nitrogen cylinder when in storage, transit, or use.
- When transporting nitrogen cylinder, use an open or well-ventilated vehicle.
- Store nitrogen cylinder upright, with protective cap installed, and secure to a wall or vertical support by means of restraining straps or chains.
- Store nitrogen cylinder in a dry, cool, well-ventilated, secure area protected from the weather.
- Never expose nitrogen cylinder to corrosive materials such as ice melting compounds.
- Protect nitrogen cylinder from wet or damp ground.
- Never attempt to mix different gases in nitrogen cylinder or use nitrogen cylinder to store a different gas.
- Refilling of nitrogen cylinder is only to be performed by a qualified supplier of compressed gases.

Safety is a primary concern in the design, manufacture, sale, and use of the Hornet. Danuser confirms to you, our customer, our concern for safety.

## **DANGER**

**Improper operation of this Hornet can cause serious personal injury or death. Operation of this attachment should only be done by a competent adult acting in compliance with the Operator's Manual. Since Hornet operations are beyond our control, we disclaim all liability for any damages, injuries, or death which may result.**

## **WARNING**

**This product can expose you to chemicals known to the State of California to cause cancer and birth defects or other reproductive harm. For more information go to [www.P65Warnings.ca.gov/product](http://www.P65Warnings.ca.gov/product).**

# Decals & Safety Signs

## Hornet Skid-Steer Mount

The Hornet comes equipped with all safety signs in place. Their locations are shown in this section. Read and follow their instructions and ensure their care:

- Keep safety signs clean and legible at all times.
- Replace safety signs that are missing, illegible, or damaged.
- Ensure replacement parts installed during repair have safety signs attached.

To install new safety signs, follow these steps:

1. Clean the area where the safety sign is to be placed.
2. Spray a little soapy water on the surface where the safety sign is to be placed.
3. Peel the backing from the safety sign, and apply it in the position shown.
4. Firmly press the safety sign, and squeeze out the air bubbles with a straight edge (e.g., a credit card).

**Model No. & Serial No.**  
Location: Unit, right side

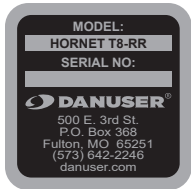

**PART NO. CA65**  
Location: Unit, right side



**PART NO. DANUSER107**  
Location: Unit, front



**PART NO. 216040 - T7**  
**PART NO. 216053 -T8-RR**  
Location: Unit, front

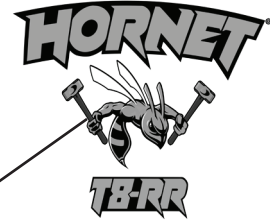

**PART NO. DIG13**  
Location: Unit, right side

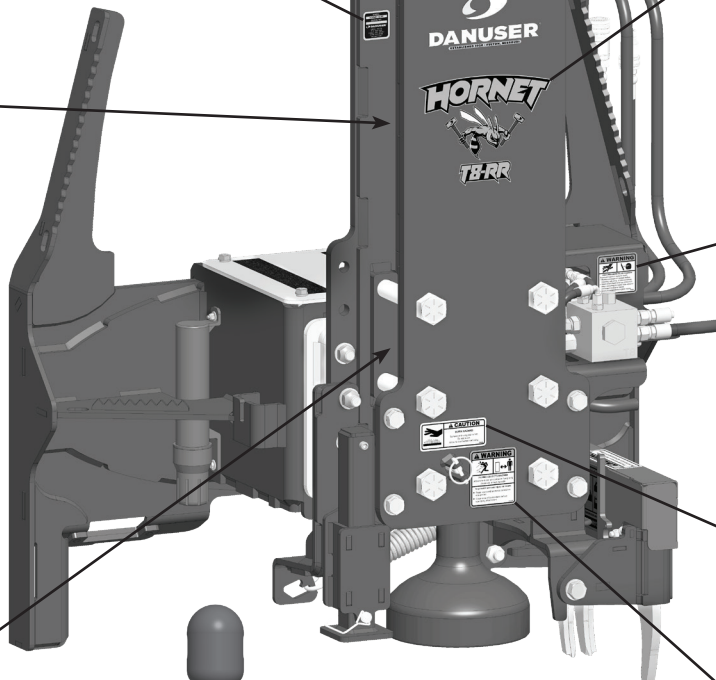

**PART NO. DIG5**  
Locations: Manifold cover; Tilt, diverter cover



**PART NO. DIG64**  
Location: Unit, front

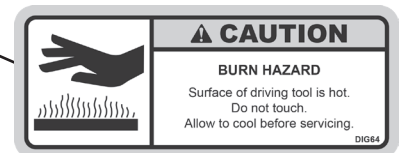

**PART NO. DIG65**  
Location: Unit, right side

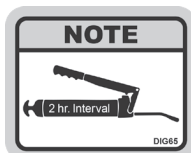

**PART NO. 236003**  
Location: Nitrogen cylinder

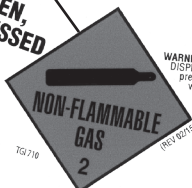

**WARNING: CONTAINS GAS UNDER PRESSURE. MAY EXPLODE IF HEATED. MAY DISPLACE OXYGEN AND CAUSE RAPID SUFFOCATION. Do not handle until all safety precautions have been read and understood. Use and store only outdoors in a well-ventilated place. Use a back flow prevention device in the piping. Use only equipment rated for cylinder pressure. Close valve after each use and when empty. Protect from sunlight when ambient temperature exceeds 52 °C (125 °F). Read and follow the Safety Data Sheet (SDS) before use.**  
Follow the **FIRST AID: IF INHALED:** Remove person to fresh air and keep comfortable for breathing. Get medical advice/attention. CAS 7727-37-9. Return with CG page. (REV 02/20)

**PART NO. DIG61**  
Location: Unit, front



**WARNING**  
Clean or replace all safety signs if they cannot be clearly read and understood.

# Decals & Safety Signs

(continued)

PART NO. 196047  
Location: Unit, rear

PART NO. DQR01  
Location: Unit, rear

PART NO. DIG60  
Location: Unit, rear

PART NO. DIG14  
Location: Unit, rear



PART NO. DIG63  
Location: Unit, rear



PART NO. DIG30  
Location: Unit, rear (only provided with concrete breaking tools)

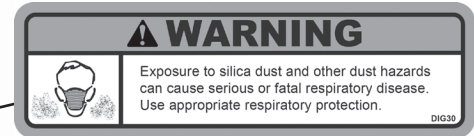

PART NO. DIG16  
Location: Unit, rear

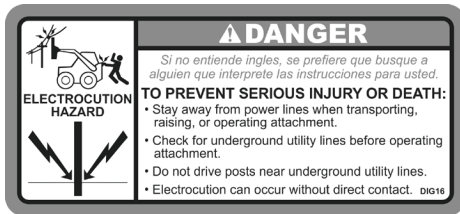

PART NO. DIG62  
Location: Unit, left side

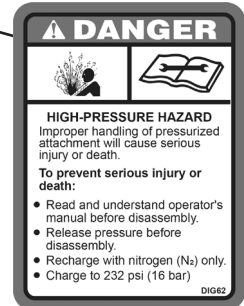

PART NO. DIG22  
Location: Grapple cover, top

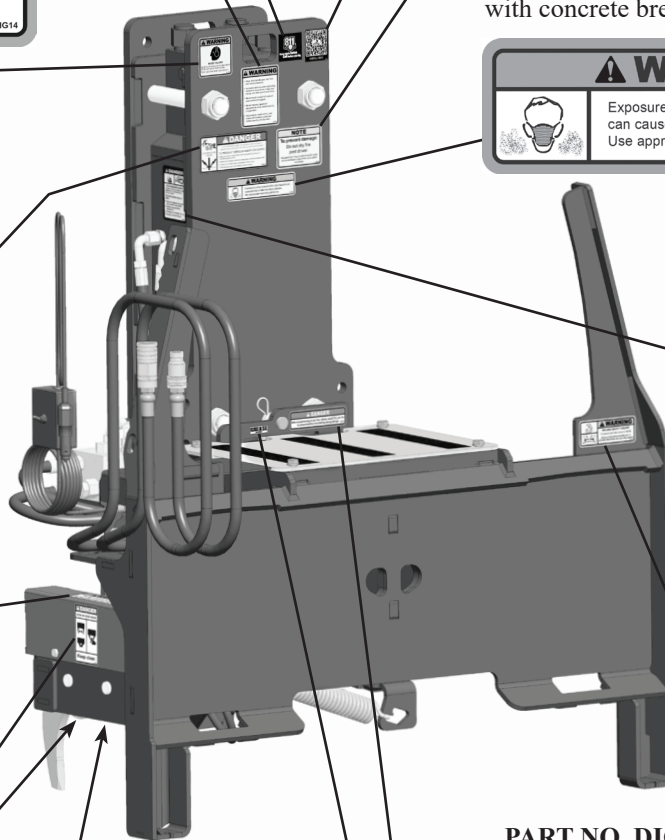

PART NO. DIG26  
Locations: Grapple cover, right; Grapple cover, left

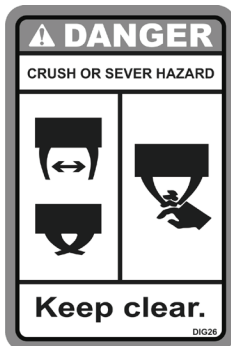

PART NO. PHDC6  
Location: Grapple cylinder, top



PART NO. 206035  
Location: Tilt quick attach plate, rear center



PART NO. DIG35  
Location: Quick attach plate, rear right

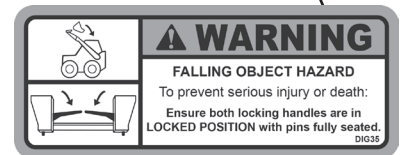

PART NO. DIG25  
Location: Tilt quick attach plate, rear right



# Decals & Safety Signs

## Hornet Backhoe & Excavator Mount

The Hornet comes equipped with all safety signs in place. Their locations are shown in this section. Read and follow their instructions and ensure their care:

- Keep safety signs clean and legible at all times.
- Replace safety signs that are missing, illegible, or damaged.
- Ensure replacement parts installed during repair have safety signs attached.

To install new safety signs, follow these steps:

1. Clean the area where the safety sign is to be placed.
2. Spray a little soapy water on the surface where the safety sign is to be placed.
3. Peel the backing from the safety sign, and apply it in the position shown.
4. Firmly press the safety sign, and squeeze out the air bubbles with a straight edge (e.g., a credit card).

**PART NO. 216040 - T7**  
**PART NO. 216053 -T8-RR**  
 Location: Unit, front

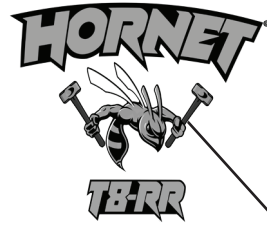

**PART NO. DANUSER107**  
 Location: Unit, front



**PART NO. DIG62**  
 Location: Unit, left side



**PART NO. DIG5**  
 Location: Intermediate, front



**PART NO. DIG64**  
 Location: Unit, front

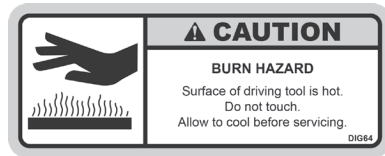

**PART NO. DIG22**  
 Location: Grapple cover, top



**PART NO. DIG61**  
 Location: Unit, front



**PART NO. PHDC6**  
 Location: Grapple cylinder, top

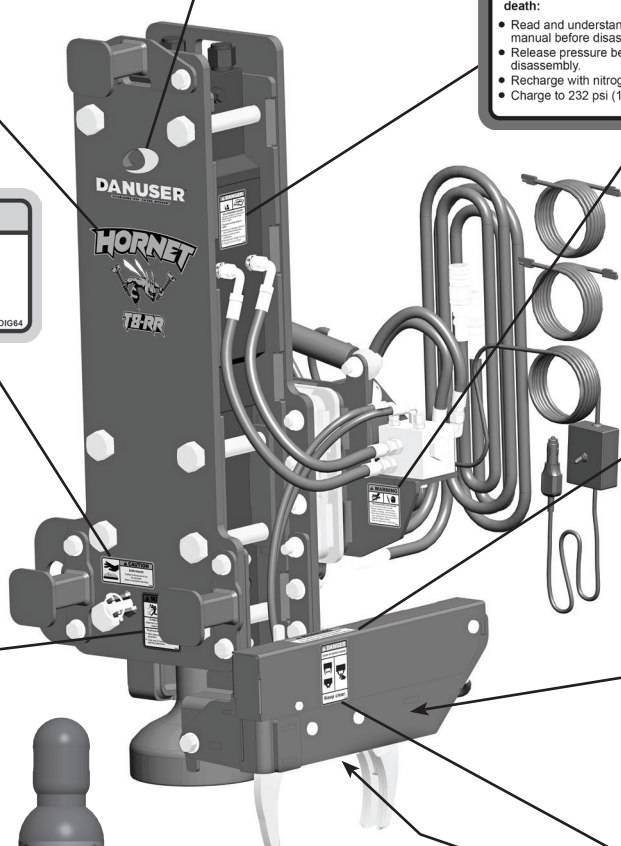

**PART NO. DIG26**  
 Locations: Grapple cover, right; Grapple cover, left

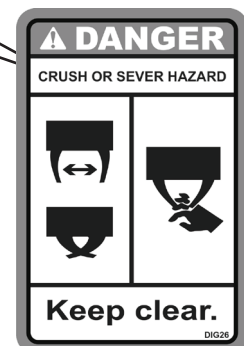

**PART NO. 236003**  
 Location: Nitrogen cylinder



**Clean or replace all safety signs if they cannot be clearly read and understood.**

**NITROGEN, COMPRESSED**

**UN1066**  
 DO NOT REMOVE THIS PRODUCT LABEL.

**NON-FLAMMABLE GAS**  
 2

**WARNING: CONTAINS GAS UNDER PRESSURE. MAY EXPLODE IF HEATED. MAY DISPLACE OXYGEN AND CAUSE RAPID SUFFOCATION. Do not handle until all safety precautions have been read and understood. Use and store only outdoors in a well-ventilated place. Use a back flow preventive device in the piping. Use only with equipment rated for cylinder pressure. Close valve after each use and strip empty. Protect from sunlight when ambient temperature exceeds 52 °C (125 °F). Seal and follow the Safety Data Sheet (SDS) before use.**

**FIRST AID: IF INHALED:** Remove person to fresh air and keep comfortable for breathing. Get medical attention. CAS 7727-37-9. Return with SDS.

# Decals & Safety Signs

(continued)

**PART NO. 196047**  
Location: Unit, rear



**PART NO. DQR01**  
Location: Unit, rear



**PART NO. CA65**  
Location: Unit, right side



**PART NO. DIG63**  
Location: Unit, rear



**PART NO. DIG14**  
Location: Unit, rear

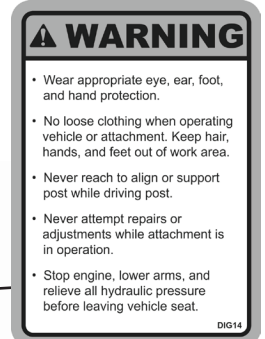

**PART NO. DIG16**  
Location: Unit, rear

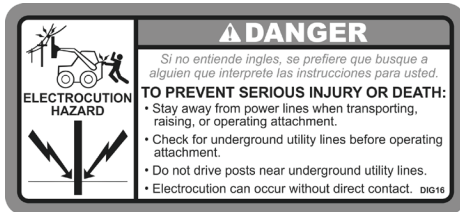

**Model No. & Serial No.**  
Location: Unit, right side

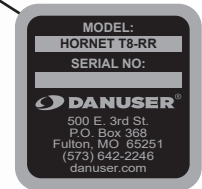

**PART NO. DIG30**  
Location: Unit, rear (only provided with concrete breaking tools)

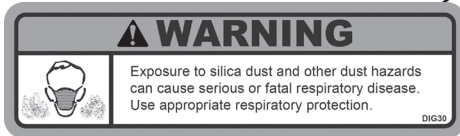

**PART NO. 206034**  
Locations: Intermediate, back; Tilt, stop plate



**PART NO. DIG59**  
Location: Intermediate, right side



**PART NO. DIG60**  
Location: Unit, rear



**PART NO. DIG65**  
Location: Unit, right side

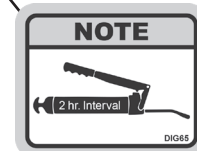

**PART NO. DIG13**  
Location: Unit, right side



**Clean or replace all safety signs if they cannot be clearly read and understood.**

# Specifications

## Hornet Skid-Steer Mount

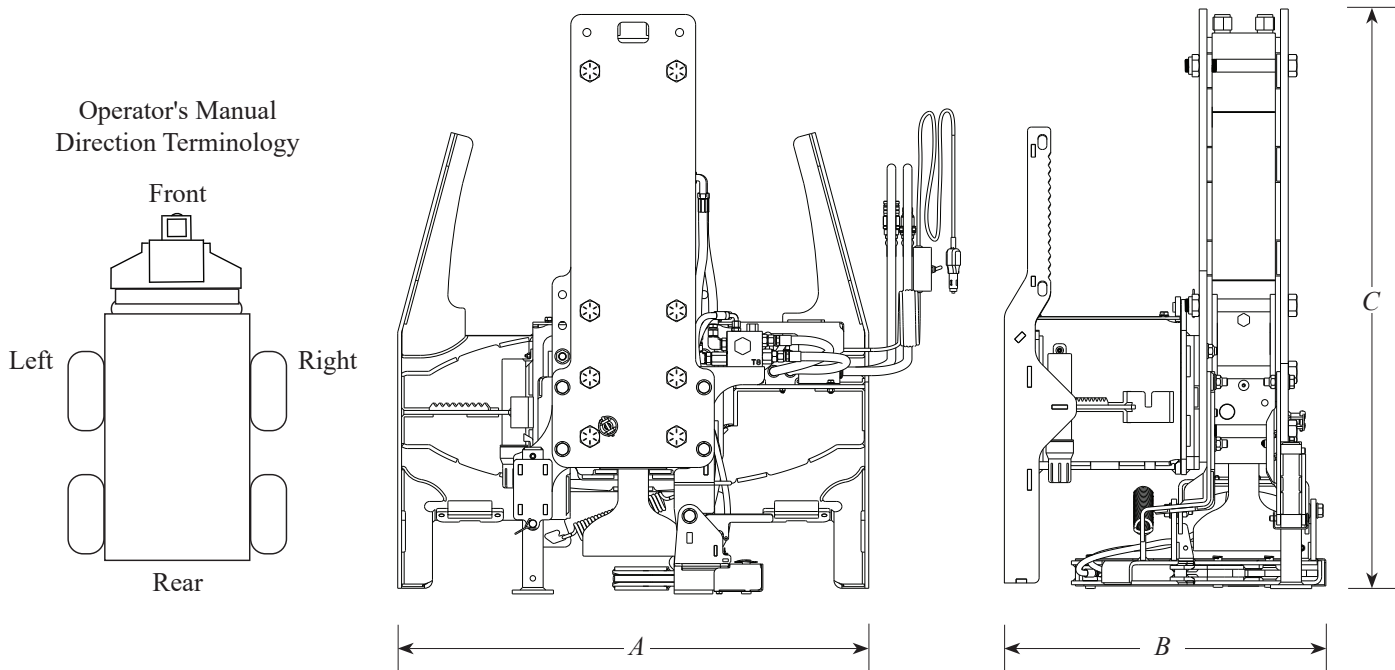

Hornet	Model T7	Model T7 w/ Grapple	Model T7 w/ Tilt	Model T7 w/ Grapple & Tilt
Overall Width (A)	45.75"			
Overall Length (B)	27"	29.2"	28.8"	31"
Overall Height (C)	46"	48.8"	46"	48.8"
Base Weight	1,241 lb.	1,361 lb.	1,376 lb.	1,486 lb.
Optional Weight Kit	Up to 616 lb., 14 weight plates (44 lb. each)		Up to 484 lb., 11 weight plates (44 lb. each)	
Max. Strikes per Minute	500-900			
Hydraulic Requirements	2,000-3,500 PSI 10-30 GPM			
Driving Tool Shaft Diameter	2.7"			
Driving Tool Inside Diameter (Max Post Size)	Domed: 7.27" Flat: 7.27"			
Energy Class	750 ft.-lb.			
Mount	Skid-Steer Quick Attach (not for front-end loaders)			

# Specifications

(continued)

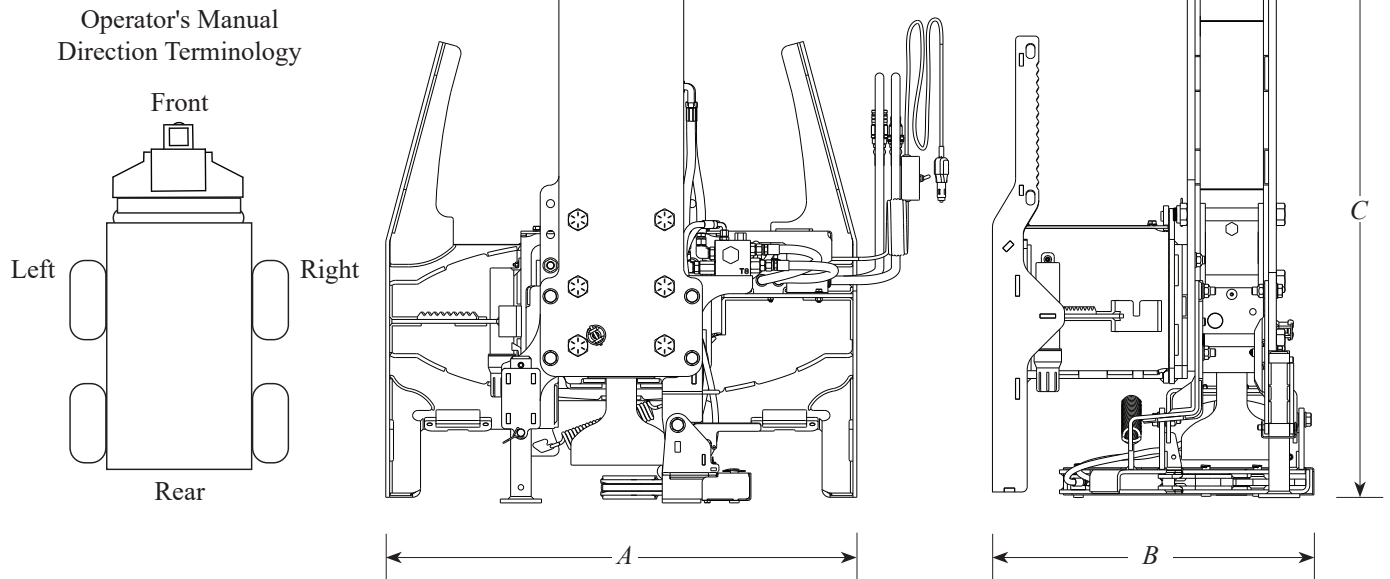

Hornet	Model T8-RR	Model T8-RR w/ Grapple	Model T8-RR w/ Tilt	Model T8-RR w/ Grapple & Tilt
Overall Width (A)	45.75"			
Overall Length (B)	27.4"	29.4"	29.2"	31.2"
Overall Height (C)	52.8"	56.3"	52.8"	56.3"
Base Weight	1,454 lb.	1,584 lb.	1,559 lb.	1,679 lb.
Optional Weight Kit	Up to 616 lb., 14 weight plates (44 lb. each)		Up to 484 lb., 11 weight plates (44 lb. each)	
Max. Strikes per Minute	400-800			
Hydraulic Requirements	2,200-3,500 PSI 13-30 GPM			
Driving Tool Shaft Diameter	3.0"			
Driving Tool Inside Diameter (Max Post Size)	Domed: 8.27" Flat: 8.27" Railroad Tie (Flat): 12.3"			
Energy Class	1,150 ft.-lb.			
Mount	Skid-Steer Quick Attach (not for front-end loaders)			

# Specifications

## Hornet Backhoe & Excavator Mount

Operator's Manual  
Direction Terminology

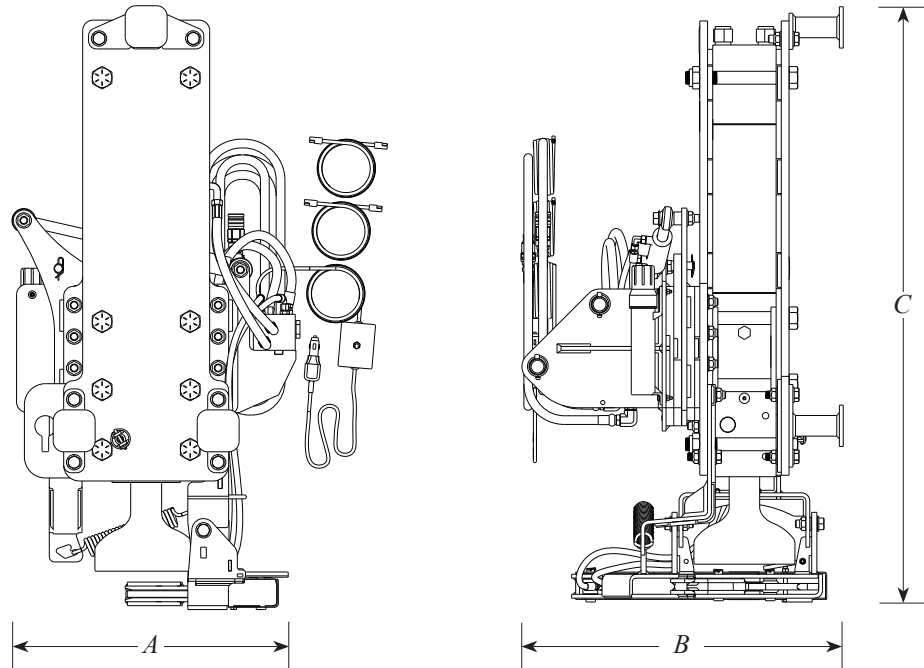
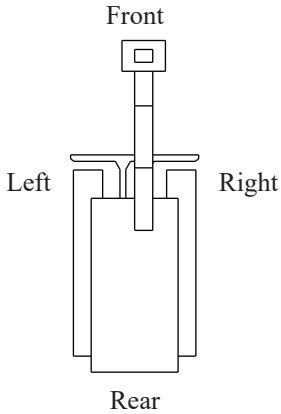

Hornet	Model T7	Model T7 w/ Grapple	Model T7 w/ Tilt	Model T7 w/ Grapple & Tilt
Overall Width (A)	27"			
Overall Length (B)	29"	29"	31"	31"
Overall Height (C)	46.5"	50.3"	46.5"	50.3"
Base Weight	926 lb.	1,051 lb.	1,061 lb.	1,186 lb.
Max. Strikes per Minute	500-900			
Hydraulic Requirements	2,000-3,500 PSI 10-30 GPM			
Driving Tool Shaft Diameter	2.7"			
Driving Tool Inside Diameter (Max Post Size)	Domed: 7.27" Flat: 7.27"			
Excavator Weight*	9,000 lb. and over			
Energy Class	750 ft.-lb.			
Mount	Backhoe & Excavator			

\*Do not exceed the rated operating capacity of your vehicle. The addition of a Hornet and its mount adds up to 1,600 lb. of additional weight. Verify that the vehicle has sufficient lifting capacity in each of the different vehicle positions. On Hornets with a grapple, the post weight will need to be considered as additional weight for lifting capacity considerations.

# Specifications

(continued)

Operator's Manual  
Direction Terminology

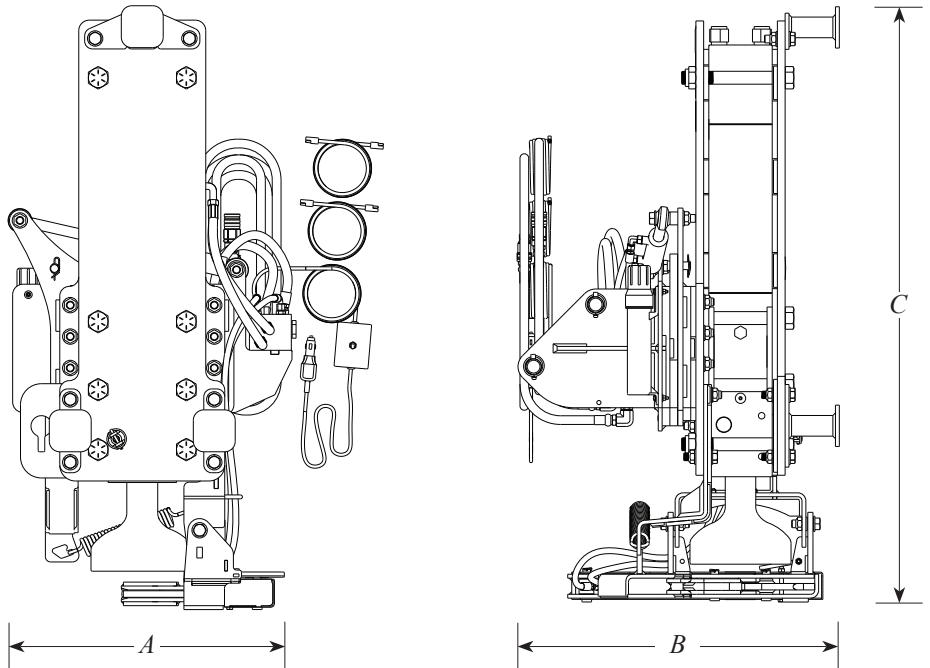
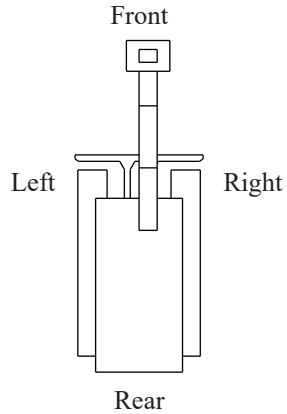

Hornet	Model T8-RR	Model T8-RR w/ Grapple	Model T8-RR w/ Tilt	Model T8-RR w/ Grapple & Tilt
Overall Width (A)	27"			
Overall Length (B)	29.5"	29.5"	31.2"	31.2"
Overall Height (C)	53.5"	57.7"	53.5"	57.7"
Base Weight	1,119 lb.	1,244 lb.	1,254 lb.	1,379 lb.
Max. Strikes per Minute	400-800			
Hydraulic Requirements	2,200-3,500 PSI 13-30 GPM			
Driving Tool Shaft Diameter	3.0"			
Driving Tool Inside Diameter (Max Post Size)	Domed: 8.27" Flat: 8.27" Railroad Tie (Flat): 12.3"			
Excavator Weight*	13,500 lb. and over			
Energy Class	1,150 ft.-lb.			
Mount	Backhoe & Excavator			

\*Do not exceed the rated operating capacity of your vehicle. The addition of a Hornet and its mount adds up to 1,600 lb. of additional weight. Verify that the vehicle has sufficient lifting capacity in each of the different vehicle positions. On Hornets with a grapple, the post weight will need to be considered as additional weight for lifting capacity considerations.

## Hydraulic Requirements

---

### Filtration Requirements:

- A filter of, at least, 10 micron filtration is required.

#### NOTE

The life of the hydraulic componentry is almost entirely dependent upon cleanliness of the oil. Instructions in your vehicle operator's manual regarding filter and oil changes should be carefully followed. Even small amounts of dirt in the hydraulic oil can cause premature hydraulic componentry failure that is not covered by warranty.

### Pressure and Flow Requirements:

- The Hornet T7 is designed to operate from 10-30 GPM and 2,000-3,500 PSI.
- The Hornet T8-RR is designed to operate from 13-30 GPM and 2,200-3,500 PSI.

### Hydraulic Fluid Selection Requirements:

- Premium grade petroleum-based fluids will provide the best performance.
- Fluids that contain anti-wear agents, rust inhibitors, anti-foaming agents, and oxidation inhibitors are recommended.
- The power cell is to be charged with nitrogen (N<sub>2</sub>) with a minimum purity of 99.98%.
- The nitrogen charge pressure is to be 232 PSI (16 bar).
- For detailed instruction on how to charge the power cell, see *Service* section, *Recharging Nitrogen*.

## Nitrogen Requirements

---

## Power Cell Grease Requirements

---

- The life of the equipment is heavily dependent upon the type of grease used and the frequency of greasing.
- Hydraulic breaker grease will provide the best performance.
- Greases that contain molybdenum disulfide, graphite, and/or copper are recommended.
- The following requirements must be met:
  - Dropping point must exceed 480°F
  - Minimum working temperature must be less than ambient temperature
  - Maximum working temperature must exceed 300°F
  - Grade NLGI 2
  - Water resistant

# Assembly & Installation

## Hornet Skid-Steer Mount

### **WARNING**

Personal protection equipment including hard hat, safety glasses, safety shoes, gloves, and hearing protection are recommended during assembly, installation, operation, maintenance, service, removal, or movement of the attachment.

### Prepare the Vehicle

Read and understand the manual for your vehicle before assembling or installing the Hornet. The vehicle must be equipped with a skid-steer quick attach mount and auxiliary hydraulics. The use of the Hornet may require the addition of counterweights to ensure the combined weight of the attachment and load does not exceed the rated capacity of your vehicle.

### **WARNING**

**Do not exceed the vehicle's rated operating load. If necessary, use sufficient counterweights.**

The use of a helper is recommended when assembling and installing the Hornet.

#### *Recommended Tools*

- 9/16" wrench
- Band cutter
- Grease gun

STEP 1: Place the pallet containing the Hornet on level ground.

STEP 2: Using a 9/16" wrench, remove the bolts securing the Hornet to the pallet. With the band cutter, remove banding from nitrogen cylinder, wiring harness (for tilt models), and box containing the post pulling chain and nitrogen gas charging kit. Attach the post pulling chain to the post pulling bracket. Store nitrogen cylinder and charging kit in an accessible location, not attached to the Hornet.

### **WARNING**

**The nitrogen cylinder is a potential hazard due to the energy it contains at high pressure. Improper handling can result in a high pressure energy release. The nitrogen cylinder should be handled by someone familiar with the hazards of compressed gas.**

- Do not store nitrogen cylinder on or in Hornet.
- Never lift nitrogen cylinder by its protective cap or valve.
- When moving nitrogen cylinder, never drop, drag, roll, slide, or carry nitrogen cylinder in a horizontal position as the cylinder valve may be broken off.
- Subjecting nitrogen cylinder to mechanical shocks may cause damage to valve.
- Never allow any part of the nitrogen cylinder to be exposed to temperatures exceeding 125°F.
- Store nitrogen cylinder upright, with protective cap installed, and secure to a wall or vertical support by means of restraining straps or chains.
- Store nitrogen cylinder in a dry, cool, well-ventilated, secure area protected from the weather.
- Never expose nitrogen cylinder to corrosive materials such as ice melting compounds.
- Protect nitrogen cylinder from wet or damp ground.

# Assembly & Installation

(continued)

## ⚠️ WARNING

Never place any part of your body where it would be in danger if movement should occur during assembly, installation, operation, maintenance, service, removal, or movement of the Hornet.

STEP 3: Park the vehicle on level ground, and install the Hornet by following your vehicle operator's manual for installing an attachment.

## ⚠️ WARNING

The Hornet must be securely latched to the vehicle. Ensure both locking handles are in the locked position with pins fully seated. An improperly latched Hornet can fall without warning.

STEP 4: If equipped with grapple, raise the Hornet slightly, pin the parking stand (1) into the up position, and disengage the grapple lock (2). The grapple lock can be disengaged by rotating the yellow grapple lock handle clockwise while pressing down on the grapple cover. The grapple lock handle should rest against the grapple case when not in use.

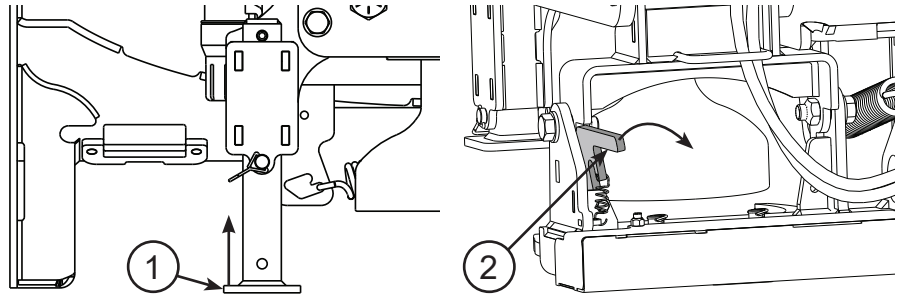

STEP 5: Have the helper remove the klik pin as well as the small retention pin on the front of the unit.

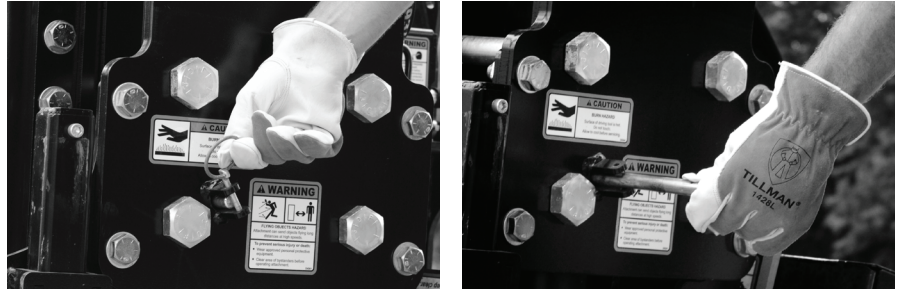

STEP 6: Have the helper remove the large retention pin from the right side of the Hornet by using the smaller retention pin to push the larger retention pin out until it can be grasped and pulled by hand.



STEP 7: If attached to the pallet, remove the driving tool. Place the driving tool on an elevated platform such as a trailer bed.

# Assembly & Installation

(continued)

## DANGER

Never allow anyone under the attachment at any time.

STEP 8: Move the vehicle to the elevated platform and have the helper orient the driving tool so that the retention pin slot is facing the vehicle. When using the Hornet equipped with a grapple, blocking may be necessary.



## WARNING

**Never work under equipment supported by hydraulics. Even with the vehicle shut off, equipment can suddenly drop if controls are actuated or hydraulic lines burst.**

STEP 9: Pull the vehicle forward until the driving tool is aligned with the bushing on the bottom of the driver. Once the tool is aligned, slowly lower the driver onto the tool. Pay careful attention to the tilt angle of the driver.

STEP 10: Lower the driver until the retention pin slot can be seen through the retention pin hole.



STEP 11: Have the helper reinstall the large retention pin with the groove oriented to the right of the Hornet. (When the large retention pin is properly installed, the ends of the pin will be flush with the power cell on both sides.)



STEP 12: Have the helper reinstall the small retention pin and secure with klik pin.

STEP 13: Using a grease gun, grease zerk on the right-hand side of the power cell. If equipped with tilt, grease the three (3) zerks on the top front side of the weight box. For more information, see *Maintenance & Lubrication*.

# Assembly & Installation

(continued)

STEP 14: Using the band cutter, remove zip-ties from hydraulic lines.

STEP 15: Connect the hydraulic hoses to the vehicle's auxiliary hydraulics.

## **WARNING**

**Before connecting or disconnecting hydraulic lines or fittings, be sure to relieve all pressure by cycling all hydraulic controls after shutdown. Remember hydraulic systems are under pressure whenever the engine is running and may hold pressure after shutdown.**

**NOTE** Ensure quick couplers are clean prior to connection

**NOTE** Hose routing is the responsibility of the operator. Pinched and/or stretched hoses are not covered under the warranty.

*If the Hornet is equipped with tilt, follow Steps 16-18.*

STEP 16: Connect the wiring harness to the diverter valve, and route the wires along the hydraulic hoses to the vehicle. Secure wires with zip-ties.

STEP 17: Route the control portion of the wiring harness along the loader arm of the vehicle and into the cab. Secure wires with zip-ties. Mount the switch out of the way of other controls.

**NOTE** Keep wiring a safe distance from hot components such as heater or exhaust.

STEP 18: Connect the wiring harness to a 12-volt auxiliary power outlet. If necessary, consult your dealer.

# Assembly & Installation

(continued)

## **⚠️ WARNING**

Personal protection equipment including hard hat, safety glasses, safety shoes, gloves, and hearing protection are recommended during assembly, installation, operation, maintenance, service, removal, or movement of the attachment.

## **⚠️ CAUTION**

Always use two people to handle heavy, unwieldy components during assembly, installation, maintenance, service, removal, or movement of the attachment.

### Installation of Additional Weight Kit

For reduced vibration, and more efficient driving, additional weight can be added by installing an additional weight kit, PN 200076 or PN 214201 (for tilt models).

#### *Recommended Tools*

- 3/4" wrench

STEP 1: With the driver on a level surface, use a 3/4" wrench to remove the four (4) cover plate bolts and lock washers. Remove the cover plate.

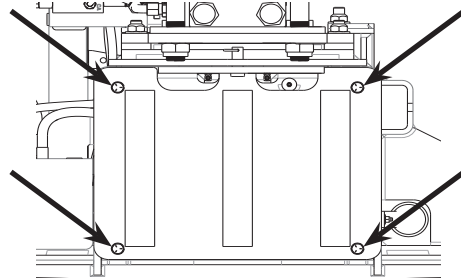

STEP 2: Starting at the front of the weight box, insert ballast plates as shown.

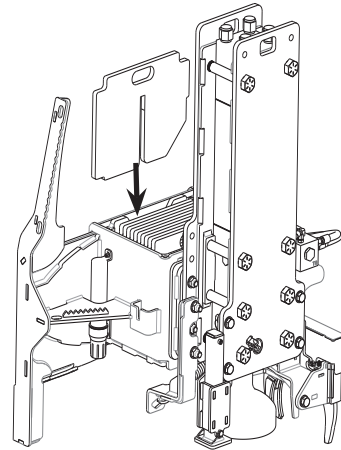

STEP 3: Reinstall the cover plate and secure with the four (4) bolts and lock washers.

# Assembly & Installation

## Hornet Backhoe & Excavator Mount

### WARNING

Personal protection equipment including hard hat, safety glasses, safety shoes, gloves, and hearing protection are recommended during assembly, installation, operation, maintenance, service, removal, or movement of the attachment.

### Prepare the Vehicle

Read and understand the manual for your vehicle before assembling or installing the Hornet. The vehicle must be equipped with auxiliary hydraulics. The use of the Hornet may require the addition of counterweights to ensure the combined weight of the attachment and load does not exceed the rated capacity of your vehicle.

### WARNING

**Do not exceed the vehicle's rated operating load. If necessary, use sufficient counterweights.**

The use of a helper is recommended when assembling and installing the Hornet.

#### *Recommended Tools*

- 9/16" wrench
- Band cutter
- Grease gun

STEP 1: Place the pallet containing the Hornet on level ground. With the band cutter, remove banding from nitrogen cylinder, wiring harness (for tilt models), and box containing the post pulling chain and nitrogen gas charging kit. Attach the post pulling chain to the post pulling bracket. Store nitrogen cylinder and charging kit in an accessible location, not attached to the Hornet.

### WARNING

**The nitrogen cylinder is a potential hazard due to the energy it contains at high pressure. Improper handling can result in a high pressure energy release. The nitrogen cylinder should be handled by someone familiar with the hazards of compressed gas.**

- Do not store nitrogen cylinder on or in Hornet.
- Never lift nitrogen cylinder by its protective cap or valve.
- When moving nitrogen cylinder, never drop, drag, roll, slide, or carry nitrogen cylinder in a horizontal position as the cylinder valve may be broken off.
- Subjecting nitrogen cylinder to mechanical shocks may cause damage to valve.
- Never allow any part of the nitrogen cylinder to be exposed to temperatures exceeding 125°F.
- Store nitrogen cylinder upright, with protective cap installed, and secure to a wall or vertical support by means of restraining straps or chains.
- Store nitrogen cylinder in a dry, cool, well-ventilated, secure area protected from the weather.
- Never expose nitrogen cylinder to corrosive materials such as ice melting compounds.
- Protect nitrogen cylinder from wet or damp ground.

# Assembly & Installation

(continued)

## **⚠ WARNING**

Never place any part of your body where it would be in danger if movement should occur during assembly, installation, operation, maintenance, service, removal, or movement of the Hornet.

STEP 2: Before removing the Hornet from the pallet, attach the vehicle mount. Remove the two vehicle mount pins (1) by removing the klik pins (2) from one side. Insert the vehicle mount (3) into the intermediate mount (4). Reinstall the two vehicle mount pins (1), one in the top set of holes and the other in the bottom middle set of holes in the mount. Reinstall the two klik pins (2).

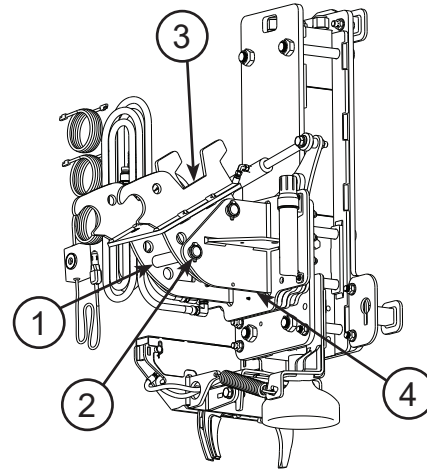

STEP 3: With the Hornet still secured to the pallet, park the vehicle on level ground, and install the Hornet by following your vehicle operator's manual for installing an attachment.

## **⚠ WARNING**

**The Hornet must be securely latched to the vehicle. Ensure quick attach latching method is properly secured. An improperly latched Hornet can fall without warning.**

STEP 4: With the driver secured to the vehicle, use a 9/16" wrench to remove the bolts securing the Hornet to the pallet. Using the band cutter, remove the bands attaching the Hornet to the pallet.

STEP 5: Lift the driver off the pallet and test the range of motion. Watch for potential contact between the driver and the vehicle or vehicle's arm. If necessary, adjust the mounting location to improve the range of motion or to avoid contact between the vehicle and the Hornet. To adjust the mount, lay the driver down on the ground with its weight fully supported. Referencing the image from Step 2, remove the lower klik pin (2) and vehicle mount pin (1), and rotate the mount up or down as required. Reinstall the vehicle mount pin (1) and klik pin (2). Re-test the range of motion.

STEP 6: If equipped with grapple, raise the Hornet slightly and disengage the grapple lock. The grapple lock can be disengaged by rotating the yellow grapple lock handle clockwise while pressing down on the grapple cover. The grapple lock handle should rest against the grapple case when not in use.

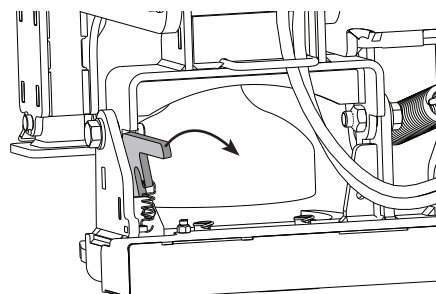

# Assembly & Installation

(continued)

STEP 7: Have the helper remove the klik pin as well as the small retention pin on the front of the unit.

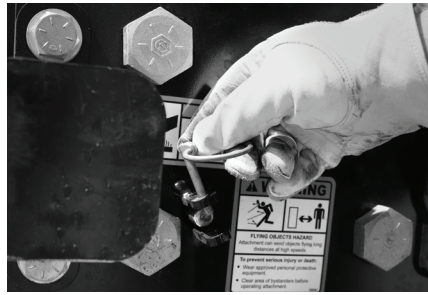

STEP 8: Have the helper remove the large retention pin from the right side of the Hornet by using the smaller retention pin to push the larger retention pin out until it can be grasped and pulled by hand.



STEP 9: If attached to the pallet, remove the driving tool. Place the driving tool on an elevated platform such as a trailer bed.

STEP 10: Move the vehicle to the elevated platform and have the helper orient the driving tool so that the retention pin slot is facing the vehicle. When using the Hornet equipped with a grapple, blocking may be necessary.



## ! WARNING

**Never work under equipment supported by hydraulics. Even with the vehicle shut off, equipment can suddenly drop if controls are actuated or hydraulic lines burst.**

STEP 11: Pull the vehicle forward until the driving tool is aligned with the bushing on the bottom of the driver. Once the tool is aligned, slowly lower the driver onto the tool. Pay careful attention to the tilt angle of the driver.

## ! DANGER

**Never allow anyone under the attachment at any time.**

# Assembly & Installation

(continued)

STEP 12: Lower the driver until the retention pin slot can be seen through the retention pin hole.

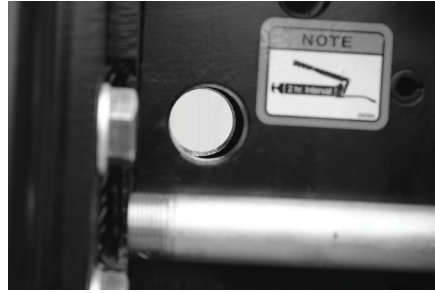

STEP 13: Have the helper reinstall the large retention pin with the groove oriented to the right of the Hornet. (When the large retention pin is properly installed, the ends of the pin will be flush with the power cell on both sides.)



STEP 14: Have the helper reinstall the small retention pin and secure with klik pin.

STEP 15: Using a grease gun, grease zerk on the right-hand side of the power cell. If equipped with tilt, grease the three (3) zerks on the back of the intermediate mount. For more information, see *Maintenance & Lubrication*.

STEP 16: Using the band cutter, remove zip-ties from the hydraulic lines.

STEP 17: Connect the hydraulic hoses to the vehicle's auxiliary hydraulics.

## **! WARNING**

**Before connecting or disconnecting hydraulic lines or fittings, be sure to relieve all pressure by cycling all hydraulic controls after shutdown. Remember hydraulic systems are under pressure whenever the engine is running and may hold pressure after shutdown.**

**NOTE** Ensure quick couplers are clean prior to connection.

**NOTE** Hose routing is the responsibility of the operator. Pinched and/or stretched hoses are not covered under the warranty.

*If the Hornet is equipped with tilt, follow Steps 18-20.*

STEP 18: Connect the wiring harness to the diverter valve, and route the wires along the hydraulic hoses to the vehicle. Secure wires with zip-ties.

# Assembly & Installation

---

(continued)

STEP 19: Route the control portion of the wiring harness along the loader arm of the vehicle and into the cab. Secure wires with zip-ties. Mount the switch out of the way of other controls.

**NOTE**

Keep wiring a safe distance from hot components such as heater or exhaust.

STEP 20: Connect the wiring harness to a 12-volt auxiliary power outlet. If necessary, consult your dealer.

# Assembly & Installation

## Changing Driving Tool

### **⚠️ WARNING**

Personal protection equipment including hard hat, safety glasses, safety shoes, gloves, and hearing protection are recommended during assembly, installation, operation, maintenance, service, removal, or movement of the attachment.

The use of a helper is recommended when installing and changing driving tools.

If a tilt option is installed, make sure the lock pin is inserted.

#### **NOTE**

Only use Danuser driving tools with the Hornet. Using a non-Danuser driving tool could cause serious damage to the power cell and will void the warranty.

#### *Recommended Tools*

- Grease gun

**STEP 1:** Park the vehicle on level ground, and install the Hornet by following your vehicle operator's manual for installing an attachment. Do not connect the hydraulic hoses to the vehicle.

### **⚠️ WARNING**

**The Hornet must be securely latched to the vehicle. Ensure quick attach latching method is properly secured. An improperly latched Hornet can fall without warning.**

**STEP 2:** If equipped with grapple, raise the Hornet slightly, pin the parking stand (1) into the up position (skid-steer mounted Hornet), and disengage the grapple lock (2). The grapple lock can be disengaged by rotating the yellow grapple lock handle clockwise while pressing down on the grapple cover. The grapple lock handle should rest against the grapple case when not in use.

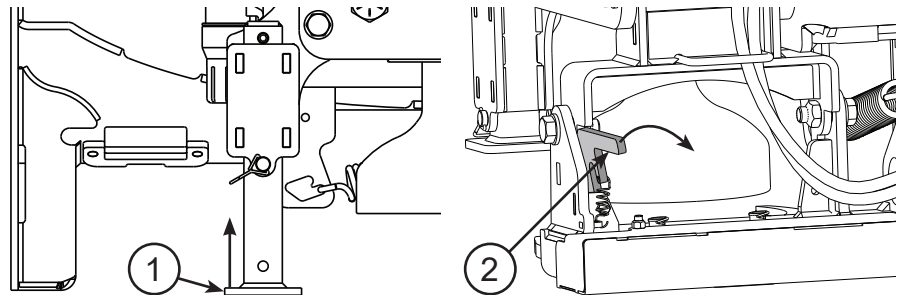

**STEP 3:** Move the Hornet to an elevated platform, such as a trailer bed, lowering the Hornet onto the platform until the driving tool is supported. When using a Hornet equipped with a grapple, blocking may be necessary.

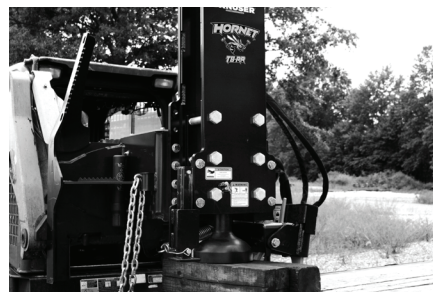

### **⚠️ WARNING**

**Never work under equipment supported by hydraulics. Even with the vehicle shut off, equipment can suddenly drop if controls are actuated or hydraulic lines burst.**

# Assembly & Installation

(continued)

## ⚠ WARNING

Never place any part of your body where it would be in danger if movement should occur during assembly, installation, operation, maintenance, service, removal, or movement of the Hornet.

STEP 4: Have the helper remove the klik pin as well as the small retention pin on the front of the unit.

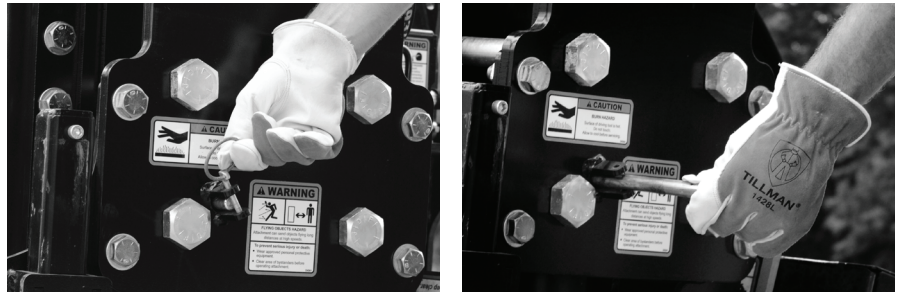

STEP 5: Have the helper remove the large retention pin from the right side of the Hornet. Use the smaller retention pin to push the larger retention pin out until it can be grasped and pulled by hand. If the driving tool is properly supported, the large retention pin should slide out with ease.



STEP 6: Using the vehicle, raise the Hornet off the driving tool.



STEP 7: Back the vehicle away from the platform.

STEP 8: Have the helper set the new driving tool on the platform with the retention pin slot facing the vehicle.

STEP 9: Pull the vehicle forward until the driving tool is aligned with the bushing on the bottom of the driver. Once the tool is aligned, slowly lower the driver onto the tool. Pay careful attention to the tilt angle of the driver.

## ⚠ DANGER

Never allow anyone under the attachment at any time.

# Assembly & Installation

---

(continued)

STEP 10: Lower the driver until the retention pin slot can be seen through the retention pin hole.

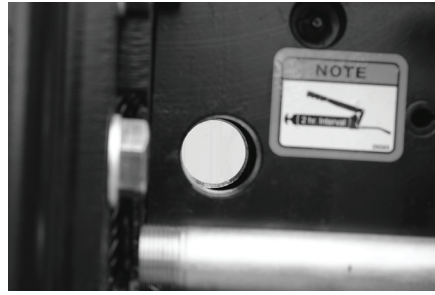

STEP 11: Have the helper reinstall the large retention pin with the groove oriented to the right of the Hornet. (When the large retention pin is properly installed, the ends of the pin will be flush with the power cell on both sides.)



STEP 12: Have the helper reinstall the small retention pin and secure with klik pin.

STEP 13: Using a grease gun, grease the zerk on the right-hand side of the power cell. For more information, see *Maintenance & Lubrication*.

## Operation

Hornet Non-Grapple  
Skid-Steer Mount

### **! DANGER**

The Hornet is designed to be operated from the vehicle seat. Keep bystanders away from the work area. Do not operate with another person in contact with any part of the Hornet.

### **! DANGER**

Do not allow riders on the equipment at any time. There is no safe place for any riders.

### **! WARNING**

Personal protection equipment including hard hat, safety glasses, safety shoes, gloves, and hearing protection are recommended during assembly, installation, operation, maintenance, service, removal, or movement of the attachment.

### **! WARNING**

Safe operation of equipment requires the operator's full attention. Avoid distractions such as radio headphones, cell phones, etc. while operating.

### **! WARNING**

Never place yourself between the vehicle and the attachment. Never allow anyone under the attachment at any time.

### **! WARNING**

Carry the load low. A heavy load can cause instability of the vehicle. Use extreme care during travel. Slow down on turns and watch out for bumps. Use all safety devices, including a seat belt, as recommended in the vehicle operator's manual.

### **! DANGER**

Contact with underground gas lines or electrical cables may result in serious injury or death from explosion or electrical shock. Before operating, call 811 or the local number to locate underground utilities. Do not drive near underground utility lines.

### **! DANGER**

Stay away from power lines when transporting, raising, or operating the attachment. Electrocutation can occur without direct contact.

### **! WARNING**

Before you operate the attachment, check over pins and connections to be sure all are securely in place. Make sure the Hornet is securely latched to the vehicle.

STEP 1: If the Hornet is equipped with tilt, remove the tilt lock pin (1) and store in the designated location (2).

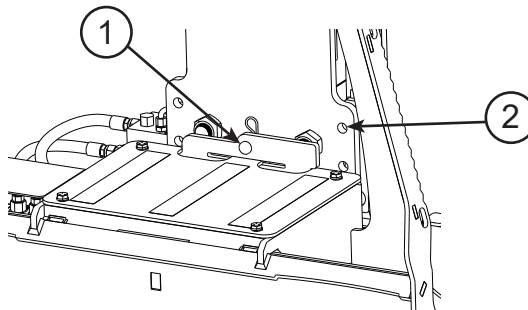

STEP 2: If using the post pulling chain as a plumb bob and/or depth gauge, attach the post pulling chain to the post pulling bracket.

#### NOTE

To use post pulling chain as a depth gauge, adjust the length of the chain in the post pulling bracket so that the hook end touches the ground as the post reaches the desired depth.

## Operation

(continued)

### **WARNING**

Keep hands, feet, hair, jewelry, and clothing away from all moving and/or rotating parts.

STEP 3: Without the grapple, the Hornet requires a second person to position the post. This person will set the post at the desired location and grasp the post securely, making sure their hands are at least thirty inches (30") from the top of the post.

### **DANGER**

**When using a second person, do not activate the auxiliary hydraulics until the second person is clear from the work area.**

STEP 4: After the post is in position, move the vehicle with the arms raised, and position the Hornet directly over the top of the post.

### **DANGER**

**Never allow anyone under the attachment at any time.**

STEP 5: Lower the Hornet onto the top of the post, ensuring the post is inside the lower portion of the driving tool. Continue lowering the Hornet until the driving tool has moved up inside the power cell, and the weight of the Hornet is supported by the post.

### **DANGER**

**After the post is in position, the second person must move away from the Hornet and vehicle.**

STEP 6: After the second person has cleared the area, place the loader arms in the float position. If the vehicle is not equipped with float, the loader arms should be lowered, applying down force to the post.

*If the Hornet is equipped with tilt, follow Steps 7-9. If not, skip to Step 10.*

STEP 7: Activate the electrical control switch.

STEP 8: Tilt the Hornet to a vertical position. Activate the auxiliary hydraulics in the forward direction to tilt the Hornet clockwise up to 20 degrees (20°). Activating the auxiliary hydraulics in reverse will tilt the Hornet counterclockwise up to 20 degrees (20°).

STEP 9: Deactivate the electrical control switch.

STEP 10: Move the vehicle slowly left, right, forward, or backward as needed until the post is vertical to the ground.

STEP 11: The Hornet can now be activated by turning the auxiliary hydraulics to the forward position. If you are not using the loader float position, the loader arms should be lowered as the post is driven into the ground.

#### **NOTE**

Maintain pressure on top of the post at all times while driving to prevent dry firing. Repeated dry firing of the Hornet will cause severe damage to the attachment and void all warranties.

STEP 12: Drive the post to the desired depth, and deactivate the auxiliary hydraulics. Raise the Hornet until the post is cleared, and move to the next post.

## Operation

Hornet w/ Grapple  
Skid-Steer Mount

### **! DANGER**

The Hornet is designed to be operated from the vehicle seat. Keep bystanders away from the work area. Do not operate with another person in contact with any part of the Hornet.

### **! DANGER**

Do not allow riders on the equipment at any time. There is no safe place for any riders.

### **! WARNING**

Personal protection equipment including hard hat, safety glasses, safety shoes, gloves, and hearing protection are recommended during assembly, installation, operation, maintenance, service, removal, or movement of the attachment.

### **! WARNING**

Safe operation of equipment requires the operator's full attention. Avoid distractions such as radio headphones, cell phones, etc. while operating.

### **! WARNING**

Never place yourself between the vehicle and the attachment. Never allow anyone under the attachment at any time.

### **! WARNING**

Carry the load low. A heavy load can cause instability of the vehicle. Use extreme care during travel. Slow down on turns and watch out for bumps. Use all safety devices, including a seat belt, as recommended in the vehicle operator's manual.

### **! DANGER**

Contact with underground gas lines or electrical cables may result in serious injury or death from explosion or electrical shock. Before operating, call 811 or the local number to locate underground utilities. Do not drive near underground utility lines.

### **! DANGER**

Stay away from power lines when transporting, raising, or operating the attachment. Electrocution can occur without direct contact.

### **! WARNING**

Before you operate the attachment, check over pins and connections to be sure all are securely in place. Make sure the Hornet is securely latched to the vehicle.

STEP 1: If the Hornet is equipped with tilt, remove the tilt lock pin (1) and store in the designated location (2).

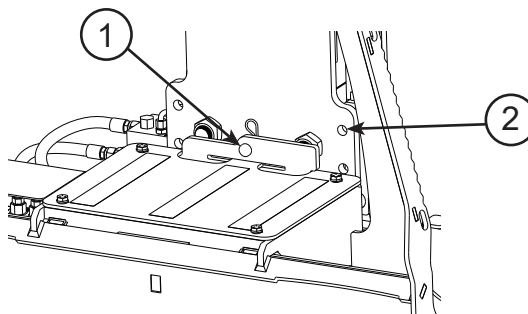

STEP 2: Raise the Hornet slightly, pin the parking stand (1) into the up position, and disengage the grapple lock (2). The grapple lock can be disengaged by rotating the yellow grapple lock handle clockwise while pressing down on the grapple cover. The grapple lock handle should rest against the grapple case when not in use.

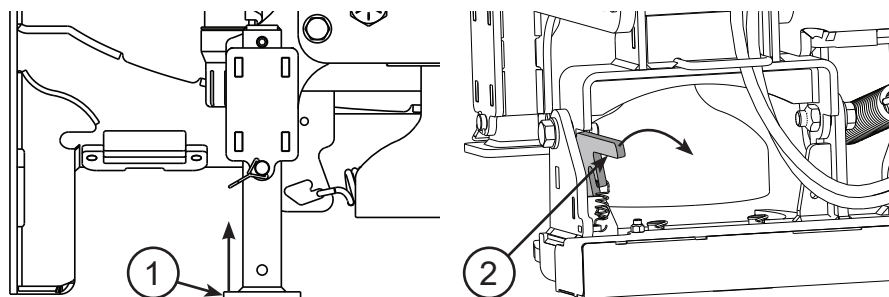

# Operation

(continued)

## **WARNING**

**Keep hands, feet, hair, jewelry, and clothing away from all moving and/or rotating parts.**

STEP 3: If using the post pulling chain as a plumb bob and/or depth gauge, attach the post pulling chain to the post pulling bracket.

### NOTE

To use the post pulling chain as a depth gauge, adjust the length of the chain in the post pulling bracket so that the hook end touches the ground as the post reaches the desired depth.

STEP 4: Position the Hornet approximately two feet (2') off the ground with the Hornet tilted slightly forward so the grapple jaws are visible.

STEP 5: Drive the vehicle forward and position the grapple jaws around the post approximately one to two inches (1-2") from the top of the post.

### NOTE

If the grapple jaws are positioned too far down the post, the top of the post will contact the outside edge of the driving tool. This will keep the post from properly feeding into the driving tool and could cause damage to the top of the post.

STEP 6: Activate the auxiliary hydraulics in the reverse direction for two (2) seconds or until the grapple jaws are firmly clamped around the post.

STEP 7: Raise the loader arms until the bottom of the post is above the ground.

STEP 8: Position the post in the desired location and lower the Hornet until the post is inside the lower portion of the driving tool.

STEP 9: Intermittently activate auxiliary hydraulics in the forward direction to release the grapple jaws from the post. The grapple will rotate up and away from the post.

STEP 10: Lower the Hornet onto the top of the post, ensuring the post is inside the lower portion of the driving tool. Continue lowering the Hornet until the driving tool has moved up inside the power cell, and the weight of the Hornet is supported by the post.

STEP 11: Place the loader arms in the float position. If the vehicle is not equipped with float, the loader arms should be lowered, applying down force to the post.

*If the Hornet is equipped with tilt, follow Steps 12-14. If not, skip to Step 15.*

STEP 12: Activate the electrical control switch.

STEP 13: Tilt the Hornet to a vertical position. Activate the auxiliary hydraulics in the forward direction to tilt the Hornet clockwise up to 20 degrees (20°). Activating the auxiliary hydraulics in reverse will tilt the Hornet counterclockwise up to 20 degrees (20°).

STEP 14: Deactivate the electrical control switch.

STEP 15: Move the vehicle slowly left, right, forward, or backward as needed until the post is vertical to the ground.

STEP 16: The Hornet can now be activated by turning the auxiliary hydraulics to the forward position. If you are not using the loader float position, the loader arms should be lowered as the post is driven into the ground.

### NOTE

Maintain pressure on top of the post at all times while driving to prevent dry firing. Repeated dry firing of the Hornet will cause severe damage to the attachment and void all warranties.

STEP 17: Drive the post to the desired depth, and deactivate the auxiliary hydraulics. Raise the Hornet until the post is cleared, and move to the next post.

## Operation

Hornet Non-Grapple  
Backhoe & Excavator  
Mount

### **⚠ DANGER**

The Hornet is designed to be operated from the vehicle seat. Keep bystanders away from the work area. Do not operate with another person in contact with any part of the Hornet.

### **⚠ DANGER**

Do not allow riders on the equipment at any time. There is no safe place for any riders.

### **⚠ WARNING**

Personal protection equipment including hard hat, safety glasses, safety shoes, gloves, and hearing protection are recommended during assembly, installation, operation, maintenance, service, removal, or movement of the attachment.

### **⚠ WARNING**

Safe operation of equipment requires the operator's full attention. Avoid distractions such as radio headphones, cell phones, etc. while operating.

### **⚠ WARNING**

Never place yourself between the vehicle and the attachment. Never allow anyone under the attachment at any time.

### **⚠ WARNING**

Carry the load low. A heavy load can cause instability of the vehicle. Use extreme care during travel. Slow down on turns and watch out for bumps. Use all safety devices, including a seat belt, as recommended in the vehicle operator's manual.

### **⚠ DANGER**

Contact with underground gas lines or electrical cables may result in serious injury or death from explosion or electrical shock. Before operating, call 811 or the local number to locate underground utilities. Do not drive near underground utility lines.

### **⚠ DANGER**

Stay away from power lines when transporting, raising, or operating the attachment. Electrocutation can occur without direct contact.

### **⚠ WARNING**

Before you operate the attachment, check over pins and connections to be sure all are securely in place. Make sure the Hornet is securely latched to the vehicle.

STEP 1: If the Hornet is equipped with tilt, remove the tilt lock pin (1) and store in the designated location (2).

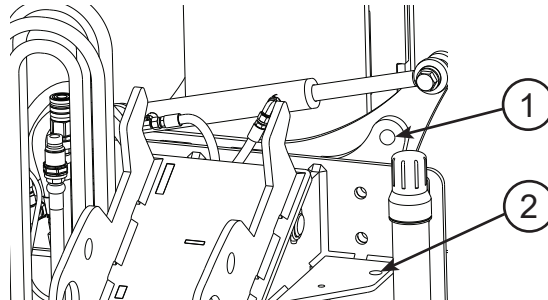

STEP 2: If using the post pulling chain as a plumb bob and/or depth gauge, attach the post pulling chain to the post pulling bracket.

#### NOTE

To use post pulling chain as a depth gauge, adjust the length of the chain in the post pulling bracket so that the hook end touches the ground as the post reaches the desired depth.

## Operation

(continued)

### WARNING

Keep hands, feet, hair, jewelry, and clothing away from all moving and/or rotating parts.

STEP 3: Without the grapple, the Hornet requires a second person to position the post. This person will set the post at the desired location and grasp the post securely, making sure their hands are at least thirty inches (30") from the top of the post.

### DANGER

**When using a second person, do not activate the auxiliary hydraulics until the second person is clear from the work area.**

STEP 4: After the post is in position, move the vehicle in position. It is recommended that the vehicle's blade faces the post. With the blade lowered, raise the Hornet and place directly over the top of the post.

### DANGER

**Never allow anyone under the attachment at any time.**

### WARNING

**Do not exceed the vehicle's rated operating load. If necessary, use sufficient counterweights.**

STEP 5: Lower the Hornet onto the top of the post, ensuring the post is inside the lower portion of the driving tool. Continue lowering the Hornet until the driving tool has moved up inside the power cell, and the weight of the Hornet is supported by the post.

### DANGER

**After the post is in position, the second person must move away from the Hornet and vehicle.**

STEP 6: After the second person has cleared the area, the vehicle's arm should be lowered, applying down force to the post.

*If the Hornet is equipped with tilt, follow Steps 7-9. If not, skip to Step 10.*

STEP 7: Activate the electrical control switch.

STEP 8: Tilt the Hornet to a vertical position. Activate the auxiliary hydraulics in the forward direction to tilt the Hornet clockwise up to 20 degrees (20°). Activating the auxiliary hydraulics in reverse will tilt the Hornet counterclockwise up to 20 degrees (20°).

STEP 9: Deactivate the electrical control switch.

STEP 10: Move the vehicle slowly left, right, forward, or backward as needed until the post is vertical to the ground.

## Operation

(continued)

## Operation

Hornet w/ Grapple  
Backhoe & Excavator  
Mount

### ! DANGER

The Hornet is designed to be operated from the vehicle seat. Keep bystanders away from the work area. Do not operate with another person in contact with any part of the Hornet.

### ! DANGER

Do not allow riders on the equipment at any time. There is no safe place for any riders.

### ! WARNING

Personal protection equipment including hard hat, safety glasses, safety shoes, gloves, and hearing protection are recommended during assembly, installation, operation, maintenance, service, removal, or movement of the attachment.

STEP 11: The Hornet can now be activated by turning the auxiliary hydraulics to the forward position. The vehicle's arm should be lowered as the post is driven into the ground.

#### NOTE

Maintain pressure on top of the post at all times while driving to prevent dry firing. Repeated dry firing of the Hornet will cause severe damage to the attachment and void all warranties.

STEP 12: Drive the post to the desired depth, and deactivate the auxiliary hydraulics. Raise the Hornet until the post is cleared, and move to the next post.

### ! WARNING

Carry the load low. A heavy load can cause instability of the vehicle. Use extreme care during travel. Slow down on turns and watch out for bumps. Use all safety devices, including a seat belt, as recommended in the vehicle operator's manual.

### ! DANGER

Contact with underground gas lines or electrical cables may result in serious injury or death from explosion or electrical shock. Before operating, call 811 or the local number to locate underground utilities. Do not drive near underground utility lines.

### ! DANGER

Stay away from power lines when transporting, raising, or operating the attachment. Electrocutation can occur without direct contact.

### ! WARNING

Before you operate the attachment, check over pins and connections to be sure all are securely in place. Make sure the Hornet is securely latched to the vehicle.

STEP 1: If the Hornet is equipped with tilt, remove the tilt lock pin (1) and store in the designated location (2).

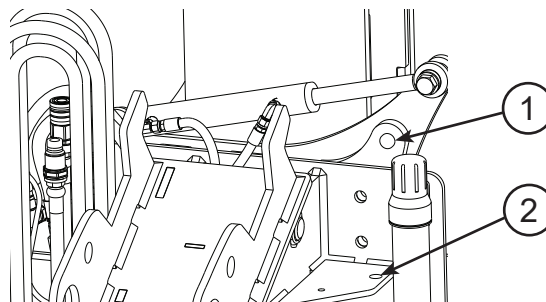

# Operation

(continued)

## ⚠ WARNING

Safe operation of equipment requires the operator's full attention. Avoid distractions such as radio headphones, cell phones, etc. while operating.

## ⚠ WARNING

Never place yourself between the vehicle and the attachment. Never allow anyone under the attachment at any time.

## ⚠ WARNING

Keep hands, feet, hair, jewelry, and clothing away from all moving and/or rotating parts.

STEP 2: Raise the Hornet slightly and disengage the grapple lock. The grapple lock can be disengaged by rotating the yellow grapple lock handle clockwise while pressing down on the grapple cover. The grapple lock handle should rest against the grapple case when not in use.

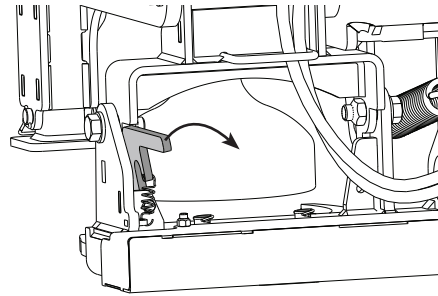

STEP 3: If using the post pulling chain as a plumb bob and/or depth gauge, attach the post pulling chain to the post pulling bracket.

### NOTE

To use the post pulling chain as a depth gauge, adjust the length of the chain in the post pulling bracket so that the hook end touches the ground as the post reaches the desired depth.

STEP 4: With the Hornet positioned over the top of the vehicle's blade and the blade lowered, position the Hornet approximately two feet (2') off the ground. Tilt the Hornet slightly forward so the grapple jaws are visible.

STEP 5: Move the vehicle and/or its arm to position the grapple jaws around the post approximately one to two inches (1-2") from the top of the post.

## ⚠ WARNING

**Do not exceed the vehicle's rated operating load. If necessary, use sufficient counterweights.**

### NOTE

If the grapple jaws are positioned too far down the post, the top of the post will contact the outside edge of the driving tool. This will keep the post from properly feeding into the driving tool and could cause damage to the top of the post.

STEP 6: Activate the auxiliary hydraulics in the reverse direction for two (2) seconds or until the grapple jaws are firmly clamped around the post.

STEP 7: Raise the vehicle's arm until the bottom of the post is above the ground.

STEP 8: Position the post in the desired location and lower the Hornet until the post is inside the lower portion of the driving tool.

STEP 9: Intermittently activate auxiliary hydraulics in the forward direction to release the grapple jaws from the post. The grapple will rotate up and away from the post.

STEP 10: Lower the Hornet onto the top of the post, ensuring the post is inside the lower portion of the driving tool. Continue lowering the Hornet until the driving tool has moved up inside the power cell, and the weight of the Hornet is supported by the post.

STEP 11: Lower the vehicle's arm to apply down force to the post.

# Operation

(continued)

*If the Hornet is equipped with tilt, follow Steps 12-14. If not, skip to Step 15.*

STEP 12: Activate the electrical control switch.

STEP 13: Tilt the Hornet to a vertical position. Activate the auxiliary hydraulics in the forward direction to tilt the Hornet clockwise up to 20 degrees (20°). Activating the auxiliary hydraulics in reverse will tilt the Hornet counterclockwise up to 20 degrees (20°).

STEP 14: Deactivate the electrical control switch.

STEP 15: Move the vehicle slowly left, right, forward, or backward as needed until the post is vertical to the ground.

STEP 16: The Hornet can now be activated by turning the auxiliary hydraulics to the forward position. The vehicle's arm should be lowered as the post is driven into the ground.

**NOTE**

Maintain pressure on top of the post at all times while driving to prevent dry firing. Repeated dry firing of the Hornet will cause severe damage to the attachment and void all warranties.

STEP 17: Drive the post to the desired depth, and deactivate the auxiliary hydraulics. Raise the Hornet until the post is cleared, and move to the next post.

# Operation

## Pulling Posts

The Hornet is capable of pulling posts. To use the post pulling feature on the Hornet, follow the instructions below.

**NOTE**

Do not use grapple to pull posts, as it may damage the attachment and void all warranties.

STEP 1: Remove the post pulling chain from the Hornet.

STEP 2: Wrap the hook end of the post pulling chain twice around the base of the post, and secure the hook back to the chain.

STEP 3: Position the Hornet so that the post pulling bracket is near the post. On excavator models, it is recommended that the tilt lock pin is installed (if applicable), the vehicle's arm is positioned over the blade, the blade is in the down position, and the Hornet is retracted as close to the vehicle as possible to maximize pulling performance.

STEP 4: Lower the Hornet to the ground.

STEP 5: Pull the chain tight. Pass the end of the chain through the post pulling bracket and secure by placing a link in the slot.



Skid-steer mounted Hornet post pulling bracket



Backhoe & excavator mounted Hornet post pulling bracket

## Operation

(continued)

## Removal & Storage

Hornet Skid-Steer Mount

### DANGER

Never allow anyone under the attachment at any time.

### WARNING

Personal protection equipment including hard hat, safety glasses, safety shoes, gloves, and hearing protection are recommended during assembly, installation, operation, maintenance, service, removal, or movement of the attachment.

STEP 6: Raise the Hornet to remove the post.

### WARNING

Reduce lifting force once the post starts to loosen from the ground. Large or deeply set posts that require high pulling force can cause the vehicle to become unstable if the post suddenly breaks loose or the chain slips.

### WARNING

Do not exceed the vehicle's rated operating load. If necessary, use sufficient counterweights.

STEP 7: Slowly lower the Hornet to the ground while moving the vehicle, or vehicle's arm, forward, backward, left, or right as needed to guide the post down to the ground to the front and right of the Hornet.

STEP 8: Remove the post pulling chain from the post.

Before storage, the Hornet should be thoroughly cleaned, washing off all dirt and grime. Make sure the hydraulic system is properly sealed against contaminants entering the unit. Always store the Hornet in a dry, covered location.

STEP 1: Remove and store the post pulling chain.

STEP 2: If equipped with tilt, install the tilt lock pin in the lock out position.

STEP 3: If equipped with a grapple, lower the parking stand by pulling the square wire lock pin and repositioning it in the top hole of the leg. Rotate the grapple underneath the power unit, then rotate the grapple lock counterclockwise to lock the grapple in the storage position.

**NOTE** Always store the Hornet with the grapple horizontal.

STEP 4: Lower the Hornet onto a flat, level surface in an area where children do not play.

STEP 5: Disconnect the hydraulic hoses from the vehicle's auxiliary hydraulics.

### WARNING

Before connecting or disconnecting hydraulic lines or fittings, be sure to relieve all pressure by cycling all hydraulic controls after shutdown. Remember hydraulic systems are under pressure whenever the engine is running and may hold pressure after shutdown.

**NOTE** Connect the quick couplers together to prevent contaminants from entering the Hornet hydraulic system.

STEP 6: If equipped with tilt, disconnect the tilt wiring harness.

STEP 7: Follow your vehicle operator's manual for removing an attachment.

## Removal & Storage

(continued)

### CAUTION

Always use two people to handle heavy, unwieldy components during assembly, installation, maintenance, service, removal, or movement of the attachment.

## Removal & Storage

Hornet Excavator & Backhoe Mount

### DANGER

Never allow anyone under the attachment at any time.

### WARNING

Personal protection equipment including hard hat, safety glasses, safety shoes, gloves, and hearing protection are recommended during assembly, installation, operation, maintenance, service, removal, or movement of the attachment.

### CAUTION

Always use two people to handle heavy, unwieldy components during assembly, installation, maintenance, service, removal, or movement of the attachment.

STEP 8: Tighten any loose nuts, bolts, and hydraulic components.

STEP 9: Replace any damaged or missing safety signs.

STEP 10: Using a grease gun, grease the zerk on the right-hand side of the power cell. If equipped with tilt, grease the three (3) zerks on the top front of the weight box. For more information, see *Maintenance & Lubrication*.

Before storage, the Hornet should be thoroughly cleaned, washing off all dirt and grime. Make sure the hydraulic system is properly sealed against contaminants entering the unit. Always store the Hornet in a dry, covered location.

STEP 1: Remove and store the post pulling chain.

STEP 2: With the Hornet in the horizontal position, lower it onto a flat, level surface in an area where children do not play.

STEP 3: Disconnect the hydraulic hoses from the vehicle's auxiliary hydraulics.

### WARNING

**Before connecting or disconnecting hydraulic lines or fittings, be sure to relieve all pressure by cycling all hydraulic controls after shutdown. Remember hydraulic systems are under pressure whenever the engine is running and may hold pressure after shutdown.**

#### NOTE

Connect the quick couplers together to prevent contaminants from entering the Hornet hydraulic system.

STEP 4: If equipped with tilt, disconnect the tilt wiring harness.

STEP 5: Follow your vehicle operator's manual for removing an attachment.

STEP 6: Tighten any loose nuts, bolts, and hydraulic components.

STEP 7: Replace any damaged or missing safety signs.

STEP 8: Using a grease gun, grease the zerk on the right-hand side of the power cell. If equipped with tilt, grease the three (3) zerks on the back of the intermediate mount. For more information, see *Maintenance & Lubrication*.

# Troubleshooting

Problem	Possible Cause	Solution
Smaller post/pipe not driving straight	Post/pipe not centered in driving tool	Install domed driving tool if applicable.
Post splintering	Improper driving tool usage	Install flat driving tool if applicable.
	Post is too large to fit inside driving tool	Use proper sized posts.
Vehicle battery is dead	Tilt switch was activated too long	Deactivate tilt switch when Hornet is not in use.
Retaining pins stuck in power cell	Lack of grease	Drive pins out, inspect for wear (replace if necessary), and follow proper greasing interval.
Power cell will not operate	Incorrect hose routing	Refer to <i>Parts</i> for proper hose routing.
	Lack of hydraulic pressure	Verify vehicle is producing the minimum hydraulic pressure requirement for the power cell.
	Power cell damaged	Contact Danuser.
	Hydraulic oil temperature too low	Hydraulic oil temperature should be at least 86°F.
Power cell firing, but driving tool is not moving	Broken driving tool	Remove driving tool and inspect.
Poor driving performance	Low nitrogen pressure	Check nitrogen pressure. Refer to <i>Service</i> .
	Broken driving tool	Remove driving tool and inspect.
Operational sound change	Broken driving tool	Remove driving tool and inspect.
	Nitrogen pressure not set properly	Check nitrogen pressure. Refer to <i>Service</i> .
	Internal damage to the power cell	Contact Danuser.
Excessive vibration	Not operating in float mode	Use float mode if applicable.
	Not applying enough down force on post	Ensure the driving tool is fully seated on the post.
	No additional ballast plates added	Refer to <i>Installation of Additional Weight Kit</i>
Oil over heating	High flow activated	Ensure vehicle is not in high flow mode.
	Low oil level	Fill reservoir to proper level.
	Dirty oil or oil filter	Change oil and filter.
Tilt not working	No power to solenoid	Check electrical connections. Ensure switch is activated.
	Tilt lock pin in place	Remove tilt lock pin. Refer to <i>Operation</i> .
	Solenoid not working	Contact Danuser.
	Air in hydraulic system	Cycle hydraulics tilting Hornet fully left and right.
	Incorrect hose routing	Refer to <i>Parts</i> for proper hose routing.
	Tilt obstruction	Ensure tilt mechanism can move freely.
	Cylinder damaged	Contact Danuser.
Grapple not working	Air in hydraulic system	Cycle hydraulics until grapple jaws fully close and open.
	Incorrect hose routing	Refer to <i>Parts</i> for proper hose routing.
	Grapple obstruction	Ensure grapple mechanism can move freely.
	Cylinder damaged	Contact Danuser.
Power cell hydraulic leak	Internal seals damaged	Contact Danuser.
	Loose power cell tie rods/nuts	Tighten in a diagonal sequence as necessary.
Broken driving tool	See image on next page for location of failure and possible cause.	

For additional assistance, please call your dealer or contact Danuser direct:

Tel: (573) 642-2246  
E-mail: sales@danuser.com

# Troubleshooting

## Broken Driving Tool

(continued)

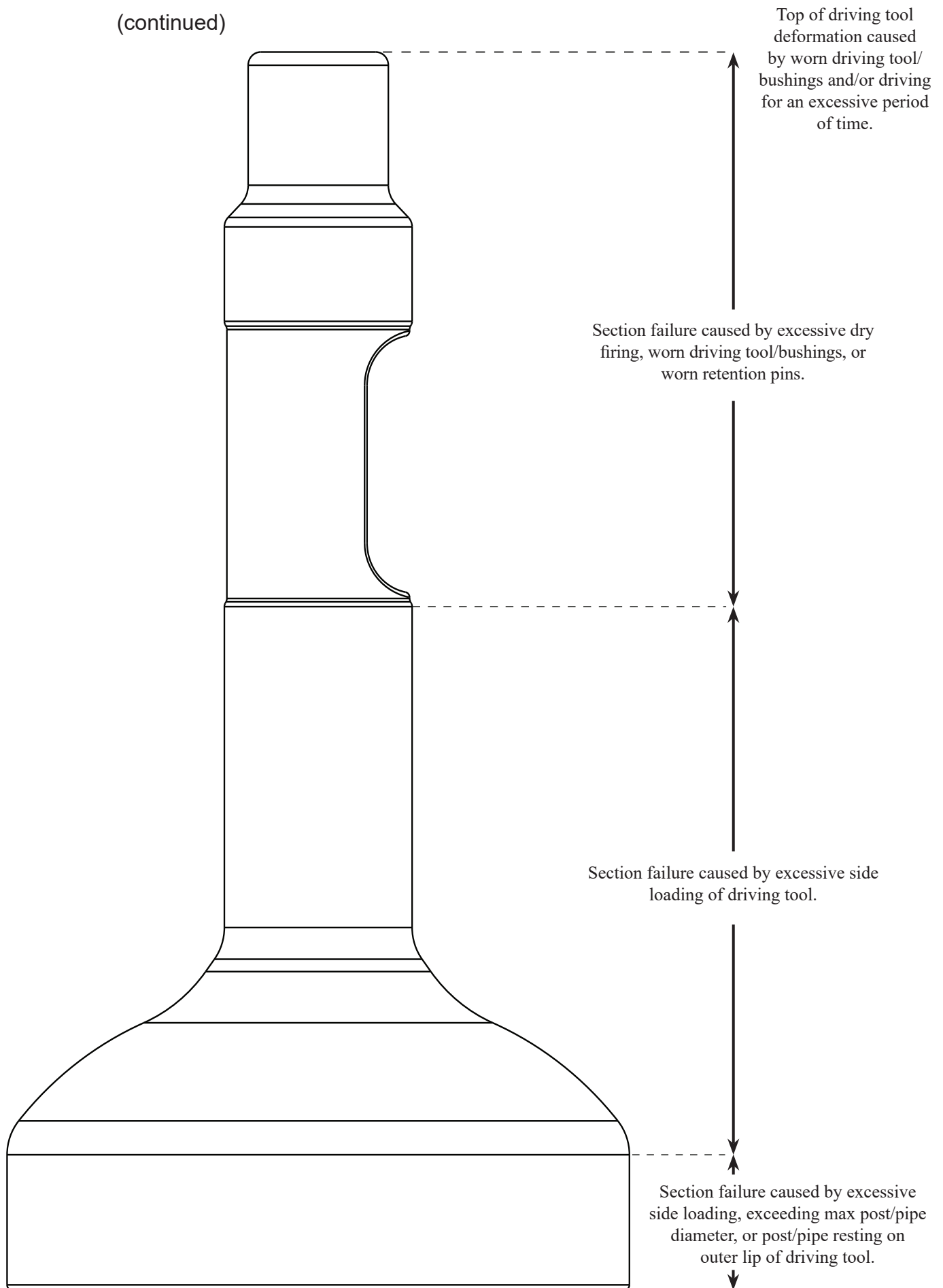

## Maintenance & Lubrication

### DANGER

Never attempt adjustments, service, or repairs while the equipment is in operation.

### DANGER

Never allow anyone under the attachment at any time.

### DANGER

Never work under equipment supported by hydraulics. Even with the vehicle shut off, equipment can suddenly drop if controls are actuated or hydraulic lines burst.

### WARNING

Personal protection equipment including hard hat, safety glasses, safety shoes, gloves, and hearing protection are recommended during assembly, installation, operation, maintenance, service, removal, or movement of the attachment.

### WARNING

Before servicing or adjusting attachment, relieve all stored energy.

Proper servicing and maintenance are key to the long life of any attachment. Careful inspection and routine maintenance helps avoid costly downtime and repair. Do not use the Hornet with any damaged parts.

### WARNING

Never check pressurized system for leaks with your bare hand. Wear proper hand and eye protection and use wood or cardboard when searching for suspected leaks. Oil escaping from pinhole leaks under pressure can penetrate skin and create a serious medical emergency. If any fluid is injected into the skin, gangrene, blood poisoning, even death may result. Obtain medical attention immediately.

### WARNING

Do not modify the attachment. Modifications may weaken the integrity of the attachment and may impair the safety, function, life, and performance of the Hornet.

### CAUTION

When making repairs or servicing the Hornet, use only parts that meet original equipment manufacturer's standards and requirements.

Maintenance	Interval
Inspect the attachment for any damage, worn parts, or cracked welds. Repair or replace as necessary.	Before each use
Check for damaged or missing safety signs. Replace as necessary.	Before each use
Check all fasteners. Ensure they are tight and secure. (Refer to <i>Torque Values Chart</i> .) Replace as necessary.	Daily
Check all hydraulic components for leaks or wear. Repair or replace as necessary.	Daily
Check for clean hydraulic oil. At all times, keep dirt and other contaminants from entering the hydraulic system during connecting and disconnecting the hydraulic system. Always use dust caps and plugs on all quick disconnects or connect couplers together when not in use.	Daily
Check nitrogen charge pressure. Refer to <i>Service</i> .	Every 50 hours or annually

# Maintenance & Lubrication

(continued)

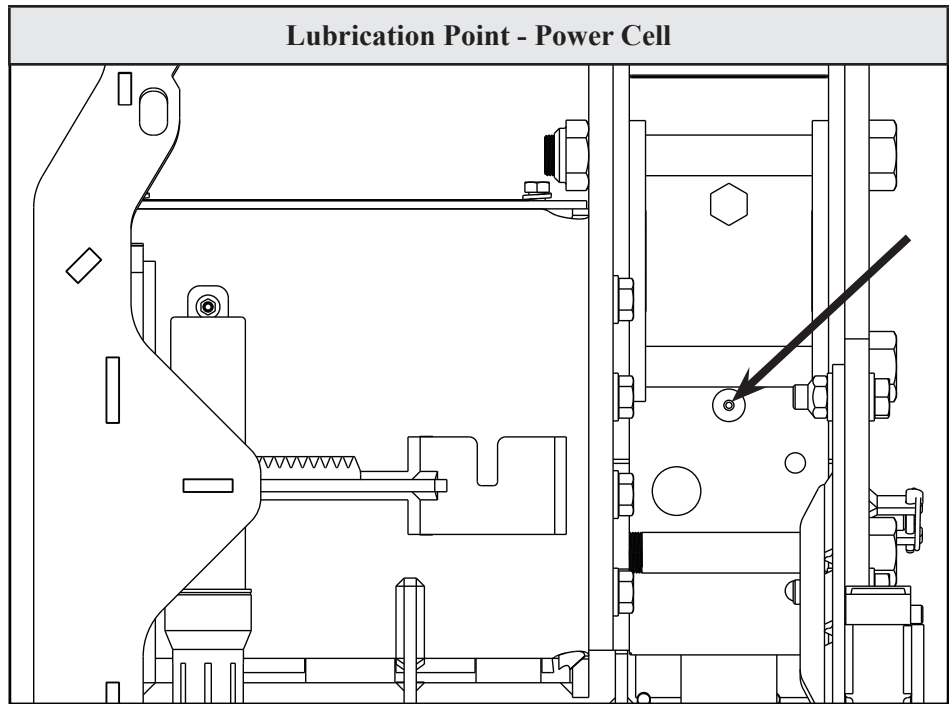

**Power Cell - 1 Zerk**

Reference *Power Cell Grease Requirements* section.

Add grease, five to seven (5-7) pumps

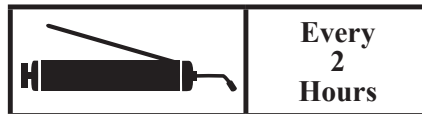

### Grease Interval:

- The power cell should be greased every two (2) hours of use. Generally, five to seven (5-7) pumps from a grease gun is sufficient.
- The number of pumps from a grease gun may vary slightly depending on grease selection, working conditions, and rate of bushing/driving tool wear.
- When changing driving tools, the power cell should also be greased.
- Insufficient greasing can cause rapid wear of driving tool, bushings, and/or retention pins.

# Maintenance & Lubrication

(continued)

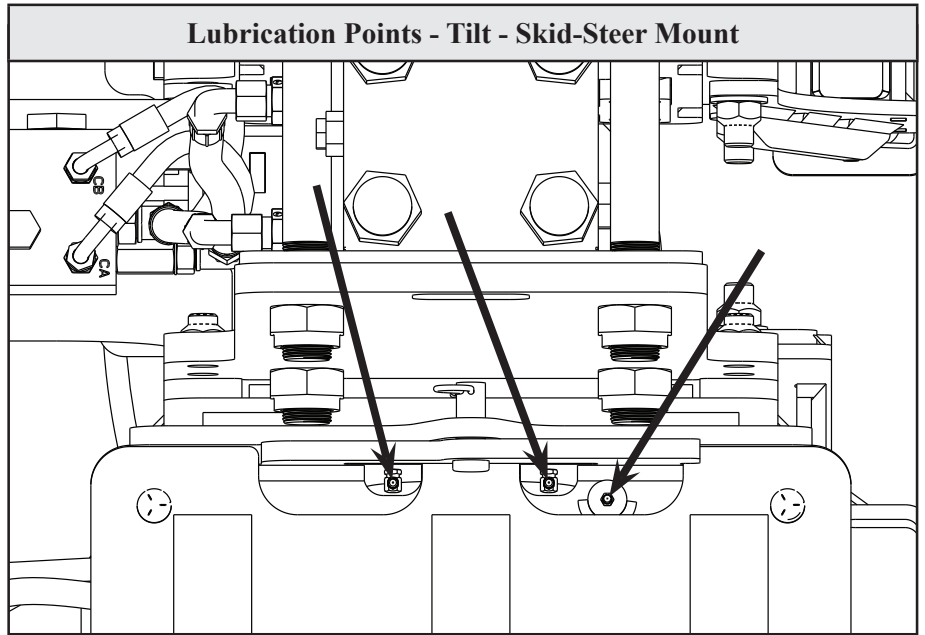

**Tilt Plate - 2 Zerks**  
**Tilt Shaft - 1 Zerk**

Add multi-purpose grease until grease emerges

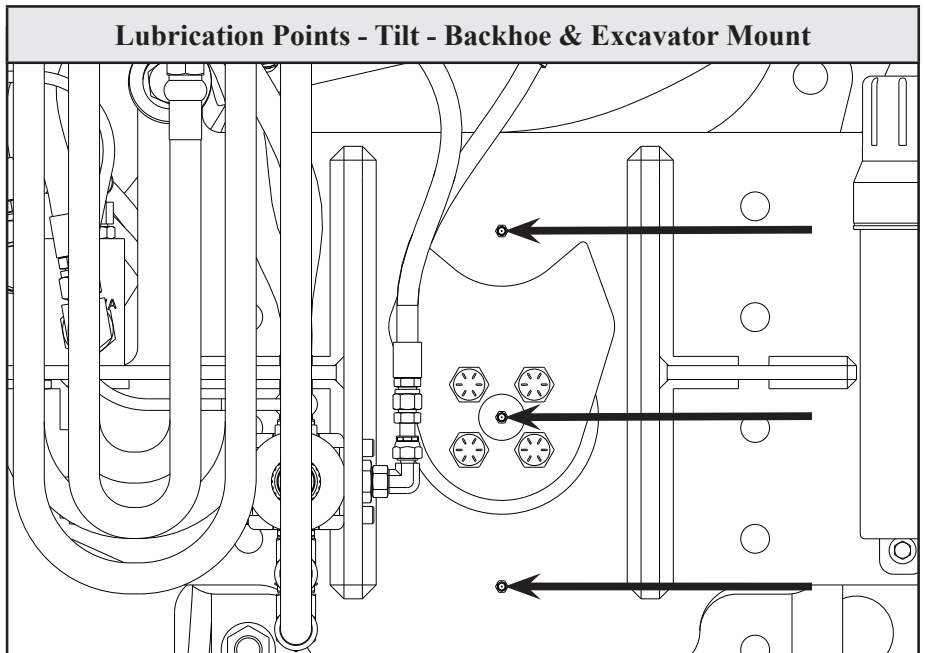
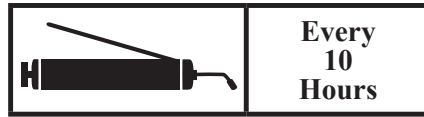

**Tilt Plate - 2 Zerks**  
**Tilt Shaft - 1 Zerk**

Add multi-purpose grease until grease emerges

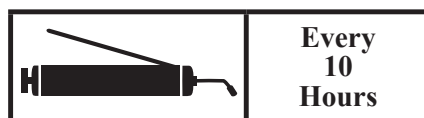

## Service

### Power Cell Nitrogen

## ! DANGER

Never attempt adjustments, service, or repairs while the equipment is in operation.

## ! DANGER

Never allow anyone under the attachment at any time.

## ! DANGER

Never work under equipment supported by hydraulics. Even with the vehicle shut off, equipment can suddenly drop if controls are actuated or hydraulic lines burst.

## ! WARNING

Personal protection equipment including hard hat, safety glasses, safety shoes, gloves, and hearing protection are recommended during assembly, installation, operation, maintenance, service, removal, or movement of the attachment.

## ! WARNING

Before servicing or adjusting attachment, relieve all stored energy.

## ! WARNING

Nitrogen is odorless, tasteless, and nonirritating. Although it is nontoxic and largely inert, it can act as a simple asphyxiant by displacing the oxygen in air to levels below that required to support life. Inhalation of nitrogen in excessive amounts can cause dizziness, nausea, vomiting, loss of consciousness, and death. The nitrogen cylinder is a potential hazard due to the energy it contains at a high pressure. Improper handling can result in high-pressure energy release. Nitrogen cylinder should be handled only by someone familiar with the hazards of compressed gases.

### Pressure Inspection

#### *Recommended Tools*

- Nitrogen fill gauge assembly (supplied with unit)
- Adjustable wrench

STEP 1: Using an adjustable wrench, remove the hex cap plug from the top left-hand side of the power cell.

STEP 2: Remove the nitrogen fill gauge assembly from its case, retract the plunger fully, and hand tighten both the pressure adjusting knob and the fill port cap.

STEP 3: Attach the nitrogen fill gauge to the power cell by hand tightening the boss directly behind the plunger.

#### **NOTE**

Ensure all fittings are clean prior to connection.

STEP 4: Push the plunger inward.

STEP 5: The pressure gauge indicates the power cell internal nitrogen pressure.

#### **NOTE**

The pressure should be set at 232 PSI (16 bar). If the pressure is correct, proceed to Step 6. If not, proceed to the *Recharging Nitrogen* section.

STEP 6: Retract the plunger.

STEP 7: Slowly unscrew the pressure adjusting knob until a short burst is heard. If nitrogen continues to be released, the plunger is not retracted all the way, and the unit will need to be recharged.

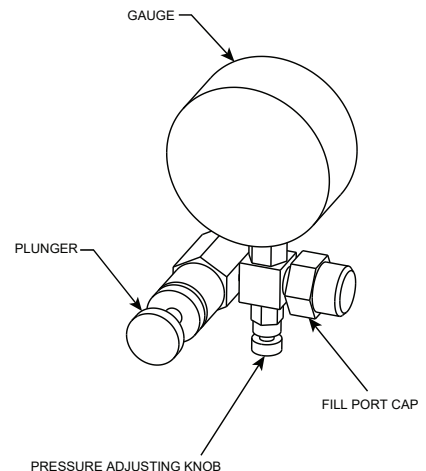

## ! WARNING

Do not discharge the contents of the nitrogen fill gauge directly towards a person.

STEP 8: With the plunger retracted, verify the pressure gauge reads zero.

STEP 9: Remove the nitrogen fill gauge assembly from the power cell.

STEP 10: Reinstall the hex cap plug.

# Service

(continued)

## Recharging Nitrogen

### Recommended Tools

- Nitrogen cylinder (supplied with unit)
- Nitrogen fill hose (supplied with unit)
- Nitrogen fill gauge assembly (supplied with unit)
- Adjustable wrench
- Strap, chain, or bungee cord

STEP 1: With the Hornet in a vertical position for skid-steer mounted versions or a horizontal position for backhoe & excavator mounted versions, lower the Hornet onto a flat, level surface.

STEP 2: Follow Steps 1-6 from the *Pressure Inspection* section.

STEP 3: Verify that the plunger is retracted and remove the fill port cap.

STEP 4: Using an adjustable wrench, attach the nitrogen fill hose to the fill gauge assembly

**NOTE** Ensure all fittings are clean prior to connection.

STEP 5: Place the nitrogen cylinder as shown below and secure using a strap, chain, or bungee cord.

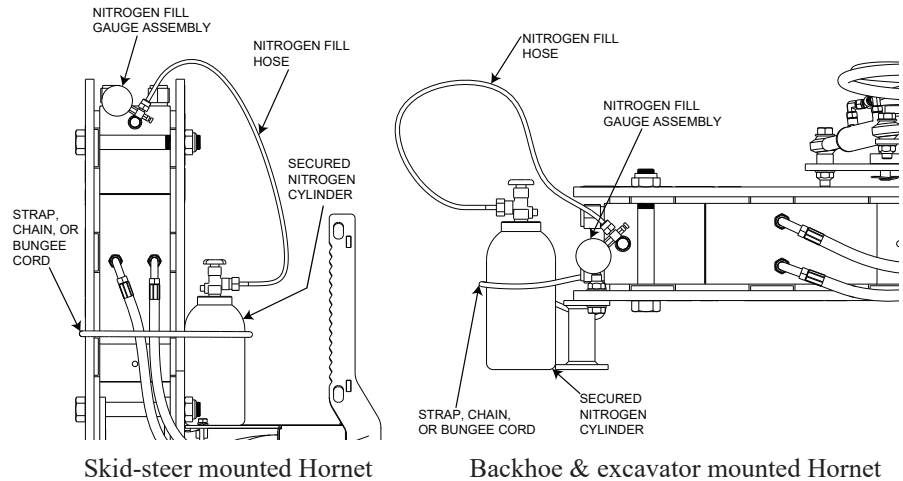

## ⚠ WARNING

- Never lift nitrogen cylinder by its protective cap or valve.
- When moving nitrogen cylinder, never drop, drag, roll, slide, or carry nitrogen cylinder in a horizontal position as the cylinder valve may be broken off.
- Secure nitrogen cylinder when in storage, transit, or use.

STEP 6: Remove the protective cap from the nitrogen cylinder.

## ⚠ WARNING

If the protective cap becomes stuck, use an adjustable strap wrench to loosen. Never stick anything into the protective cap holes in an attempt to loosen the cap. Doing so may result in damage to the valve.

## Service

(continued)

STEP 7: Using an adjustable wrench, attach the other end of the nitrogen fill hose to the nitrogen cylinder valve.

**NOTE** Ensure all fittings are clean prior to connection.

STEP 8: Push in the plunger on the fill gauge assembly.

STEP 9: With the valve pointed away from any bystanders, **SLOWLY** open the valve on the nitrogen cylinder while carefully watching the pressure gauge. As the pressure approaches 232 PSI (16 bar), close the valve on the cylinder.

### **WARNING**

- **Do not discharge the contents from the nitrogen cylinder directly towards a person.**
- **Never use a wrench to open or close the nitrogen cylinder valve. If the valve is difficult to operate, discontinue use and contact a qualified supplier of compressed gases for repairs.**

**NOTE** Nitrogen cylinder pressure can be as much as 2,200 PSI. This high pressure will damage the pressure gauge. Do not open the valve fully, and quickly close the valve when the pressure approaches 232 PSI (16 bar).

STEP 10: If the pressure slightly exceeds the target, use the pressure adjusting knob to bleed the pressure back down to the proper value.

STEP 11: With pressure set at the proper value and nitrogen cylinder valve closed, retract the plunger to lock the desired pressure in the power cell.

STEP 12: Slowly unscrew the pressure adjusting knob until a short burst is heard. If nitrogen continues to be released, the plunger is not retracted all the way, and the unit will need to be recharged.

### **WARNING**

**Do not discharge the contents of the nitrogen fill gauge directly towards a person.**

STEP 13: Remove the nitrogen fill hose from the fill gauge assembly and from the nitrogen cylinder.

STEP 14: Reinstall the protective cap on the nitrogen cylinder.

### **WARNING**

**Nitrogen cylinder protective cap must be installed at all times when cylinder is not in use.**

STEP 15: Remove the nitrogen cylinder from the driver and store in an accessible location not attached to the Hornet.

## ⚠ WARNING

- **Never lift nitrogen cylinder by its protective cap or valve.**
- **When moving nitrogen cylinder, never drop, drag, roll, slide, or carry nitrogen cylinder in a horizontal position as the cylinder valve may be broken off.**
- **Subjecting nitrogen cylinder to mechanical shocks may cause damage to valve.**
- **Never allow any part of the nitrogen cylinder to be exposed to temperatures exceeding 125°F.**
- **Store nitrogen cylinder upright, with protective cap installed, and secure to a wall or vertical support by means of restraining straps or chains.**
- **Store nitrogen cylinder in a dry, cool, well-ventilated, secure area protected from the weather.**
- **Never expose nitrogen cylinder to corrosive materials such as ice melting compounds.**
- **Protect nitrogen cylinder from wet or damp ground.**

STEP 16: Remove the nitrogen fill gauge from the power cell.

STEP 17: Reinstall the hex cap plug.

### Relieving Nitrogen Pressure

#### *Recommended Tools*

- Nitrogen fill gauge assembly (supplied with unit)
- Adjustable wrench

## ⚠ DANGER

**Release power cell nitrogen gas pressure and hydraulic oil pressure before disassembling power cell.**

STEP 1: Using an adjustable wrench, remove the hex cap plug from the top left-hand side of the power cell.

STEP 2: Remove the nitrogen fill gauge assembly from its case, retract the plunger fully, and hand tighten both the pressure adjusting knob and the fill port cap.

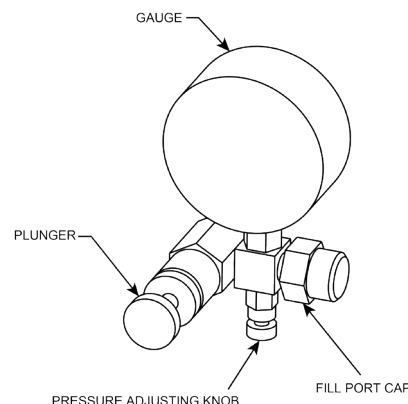

## Service

(continued)

STEP 3: Attach the nitrogen fill gauge to the power cell by hand tightening the boss directly behind the plunger.

**NOTE** Ensure all fittings are clean prior to connection.

STEP 4: Press the plunger inward.

STEP 5: **SLOWLY** open the pressure adjusting knob. The compressed nitrogen will now be released to the atmosphere. Once the pressure gauge reads 0 with the plunger pressed in, the nitrogen chamber is empty.

### **WARNING**

**Do not discharge the contents of the nitrogen fill gauge directly towards a person.**

STEP 6: Remove the nitrogen fill gauge from the power cell.

STEP 7: Reinstall the hex cap plug.

# Torque Values Chart

Torque Values Chart																	
Bolt Size (inches)	Bolt Head Identification								Bolt Size (Metric)	Bolt Head Identification							
	Grade 2		Grade 5		Grade 8		ASTM A574			Class 5.8	Class 8.8		Class 10.9		Class 12.9		
in-tpi	Nm	ft.-lb.	Nm	ft.-lb.	Nm	ft.-lb.	Nm	ft.-lb.	mm x pitch	Nm	ft.-lb.	Nm	ft.-lb.	Nm	ft.-lb.	Nm	ft.-lb.
1/4"-20	7.4	5.6	11	8	16	12	19	14	M5 x 0.8	4	3	6	5	9	7	11	8
1/4"-28	8.5	6	13	10	18	14	22	16	M6 x 1	7	5	11	8	15	11	18	13
5/16"-18	15	11	24	17	33	25	39	29	M8 x 1.25	17	12	26	19	36	27	42	31
5/16"-24	17	13	26	19	37	27	43	32	M8 x 1	18	13	28	21	39	29	46	34
3/8"-16	27	20	42	31	59	44	69	51	M10 x 1.5	33	24	52	39	72	53	84	62
3/8"-24	31	22	47	35	67	49	79	58	M10 x 0.75	39	29	61	45	85	62	98	72
7/16"-14	43	32	67	49	95	70	110	81	M12 x 1.75	58	42	91	67	125	93	148	109
7/16"-20	49	36	75	55	105	78	123	91	M12 x 1.5	60	44	95	70	130	97	153	113
1/2"-13	66	49	105	76	145	105	168	124	M12 x 1	90	66	105	77	145	105	167	123
1/2"-20	75	55	115	85	165	120	190	140	M14 x 2	92	68	145	105	200	150	235	173
9/16"-12	95	70	150	110	210	155	235	173	M14 x 1.5	99	73	155	115	215	160	254	187
9/16"-18	105	79	165	120	235	170	262	193	M16 x 2	145	105	225	165	315	230	365	269
5/8"-11	130	97	205	150	285	210	323	238	M16 x 1.5	155	115	240	180	335	245	388	286
5/8"-18	150	110	230	170	325	240	366	270	M18 x 2.5	195	145	310	230	405	300	504	372
3/4"-10	235	170	360	265	510	375	574	423	M18 x 1.5	220	165	350	260	485	355	561	414
3/4"-16	260	190	405	295	570	420	640	472	M20 x 2.5	280	205	440	325	610	450	712	525
7/8"-9	225	165	585	430	820	605	925	682	M20 x 1.5	310	230	650	480	900	665	1052	776
7/8"-14	250	185	640	475	905	670	1020	752	M24 x 3	480	355	760	560	1050	780	1231	908
1"-8	340	250	875	645	1230	910	1386	1022	M24 x 2	525	390	830	610	1150	845	1337	986
1"-12	370	275	955	705	1350	995	1555	1147	M30 x 3.5	960	705	1510	1120	2100	1550	2447	1805
1-1/8"-7	480	355	1080	795	1750	1290	1971	1454	M30 x 2	1060	785	1680	1240	2320	1710	2706	1996
1-1/8"-12	540	395	1210	890	1960	1440	2202	1624	M36 x 3.5	1730	1270	2650	1950	3660	2700	4272	3151
1-1/4"-7	680	500	1520	1120	2460	1820	2771	2044	M36 x 2	1880	1380	2960	2190	4100	3220	5095	3758
1-1/4"-12	750	555	1680	1240	2730	2010	3068	2263	<b>KEY:</b> in-tpi = nominal thread diameter in inches-threads per inch Nm = Newton-meter ft.-lb. = foot pounds mm x pitch = nominal thread diameter in millimeters by thread pitch								
1-3/8"-6	890	655	1990	1470	3230	2380	3638	2683									
1-3/8"-12	1010	745	2270	1670	3680	2710	4143	3056									
1-1/2"-6	1180	870	2640	1950	4290	3160	4823	3557									
1-1/2"-12	1330	980	2970	2190	4820	3560	5426	4002									

Torque tolerance +0%, -15% of torque values. Unless otherwise specified, use torque values listed above.



# Parts

(continued)

REF. NO.	PART NO.	DESCRIPTION	QTY.	MODEL
1	180054S	Quick Attach Weldment	1	All Models
2	206046	Bolt (1/4"-20 x 1.25", Gr. 5)	1	All Models
3	21258	Operator's Manual Canister	1	All Models
4	10195	Toplock Nut (1/4"-20)	2	All Models
5	21056	1/4" Flat Washer	2	All Models
6	206094	Carriage Bolt (1/4"-20 x 1.25", Gr. 5)	1	All Models
7	10268	Toplock Nut (3/4"-10)	8	All Models
8	200066S	Cover Plate	1	All Models
9	973	1/2" Lock Washer	4	All Models
10	206055	Bolt (1/2"-13 x 2.25", Gr. 5)	4	All Models
11	200535S	Manifold Cover	1	All Models
12	2178	3/8" Flat Washer	1	All Models
13	206012	Hydraulic Manifold	1	T7
	206013	Hydraulic Manifold	1	T8-RR
14	200080	Clamp Plate Assembly	1	T7
	180056	Clamp Plate Assembly	1	T8-RR
15	206088	Bolt (3/4"-10 x 2.5", Gr. 8)	8	All Models
16	10267	3/4" Flat Washer	16	All Models
17	*varies	Driving Tool (see <i>Parts: Driving Tools</i> )		All Models
18	10412	Toplock Nut (3/8"-16)	1	All Models
19	21157	Bolt (3/8"-16 x 1", Gr. 2)	3	All Models
20	216003	Post Pulling Chain	1	All Models
21	206101	Nitrogen Cylinder	1	All Models
22	206102	Nitrogen Gas Charge Kit	1	All Models
23	*200067	Ballast Plate (single ballast plate)	1	All Models

\* Not included with base model.

# Parts

# ! WARNING

Main Assembly w/ Grapple  
Skid-Steer Mount

This product can expose you to chemicals known to the State of California to cause cancer and birth defects or other reproductive harm. For more information go to [www.P65Warnings.ca.gov/product](http://www.P65Warnings.ca.gov/product).

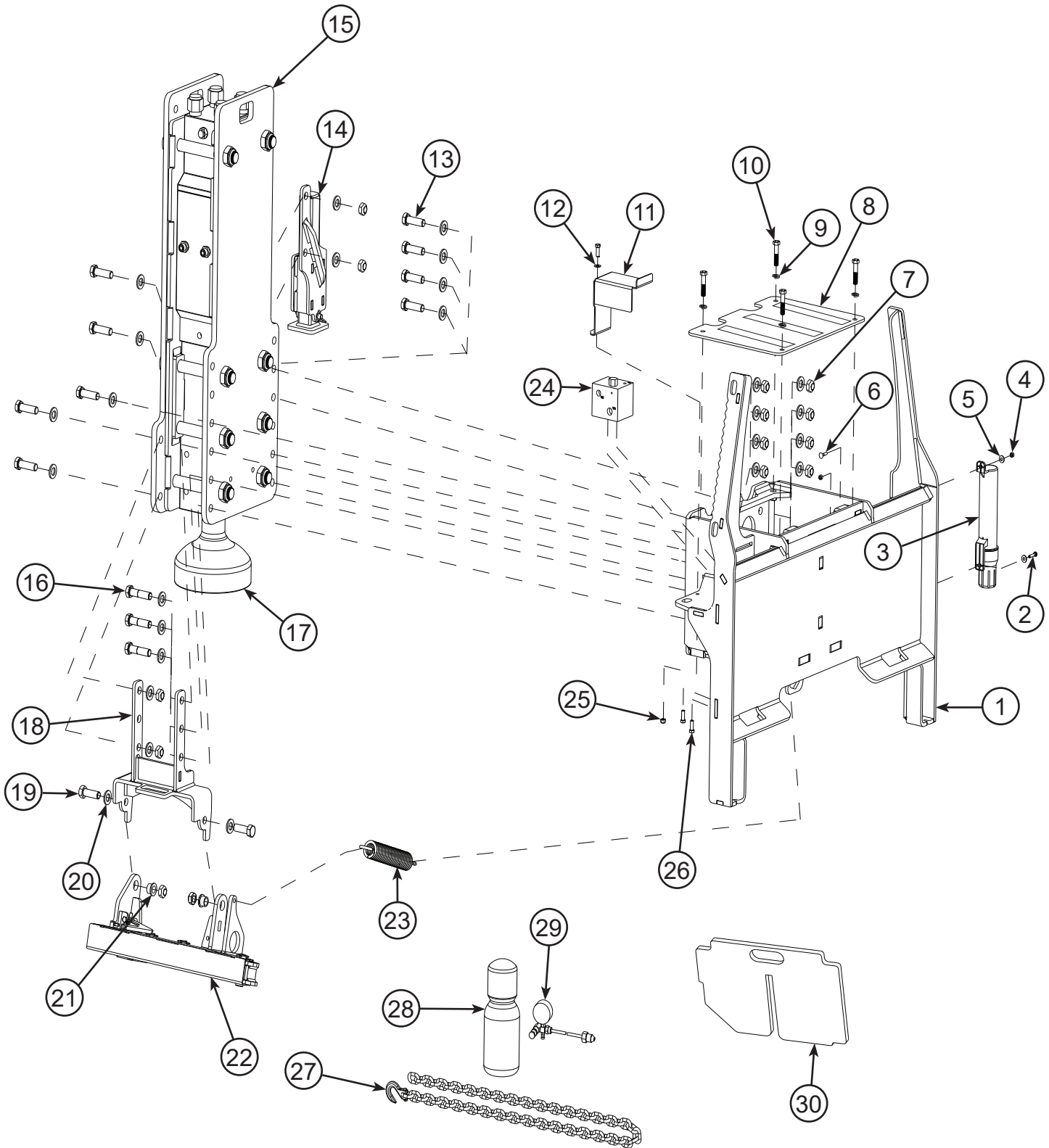

# Parts

(continued)

REF. NO.	PART NO.	DESCRIPTION	QTY.	MODEL
1	180054S	Quick Attach Weldment	1	All Models
2	206046	Bolt (1/4"-20 x 1.25", Gr. 5)	1	All Models
3	21258	Operator's Manual Canister	1	All Models
4	10195	Toplock Nut (1/4"-20)	2	All Models
5	21056	1/4" Flat Washer	2	All Models
6	206094	Carriage Bolt (1/4"-20 x 1.25", Gr. 5)	1	All Models
7	10268	Toplock Nut (3/4"-10)	14	All Models
8	200066S	Cover Plate	1	All Models
9	973	1/2" Lock Washer	4	All Models
10	206055	Bolt (1/2"-13 x 2.25", Gr. 5)	4	All Models
11	200535S	Manifold Cover	1	All Models
12	2178	3/8" Flat Washer	1	All Models
13	206088	Bolt (3/4"-10 x 2.5", Gr. 8)	9	All Models
14	210010	Kick Stand Assembly	1	All Models
15	200080	Clamp Plate Assembly	1	T7
	180056	Clamp Plate Assembly	1	T8-RR
16	206089	Bolt (3/4"-10 x 3", Gr. 8)	3	All Models
17	*varies	Driving Tool (see <i>Parts: Driving Tools</i> )		All Models
18	200565	Grapple Mount	1	T7
	200570	Grapple Mount	1	T8-RR
19	9037	Bolt (3/4"-10 x 2.25", Gr. 8)	2	All Models
20	10267	3/4" Flat Washer	26	All Models
21	206095	Grapple Bushing	2	All Models
22	200221	Grapple Assembly	1	T7
	200220	Grapple Assembly	1	T8-RR
23	206090	Grapple Spring	1	All Models
24	206012	Hydraulic Manifold	1	T7
	206013	Hydraulic Manifold	1	T8-RR
25	10412	Toplock Nut (3/8"-16)	1	All Models
26	21157	Bolt (3/8"-16 x 1", Gr. 2)	3	All Models
27	216003	Post Pulling Chain	1	All Models
28	206101	Nitrogen Cylinder	1	All Models
29	206102	Nitrogen Gas Charge Kit	1	All Models
30	*200067	Ballast Plate (single ballast plate)	1	All Models

\* Not included with base model.

# Parts

# ⚠️ WARNING

Main Assembly w/ Tilt  
Skid-Steer Mount

This product can expose you to chemicals known to the State of California to cause cancer and birth defects or other reproductive harm. For more information go to [www.P65Warnings.ca.gov/product](http://www.P65Warnings.ca.gov/product).

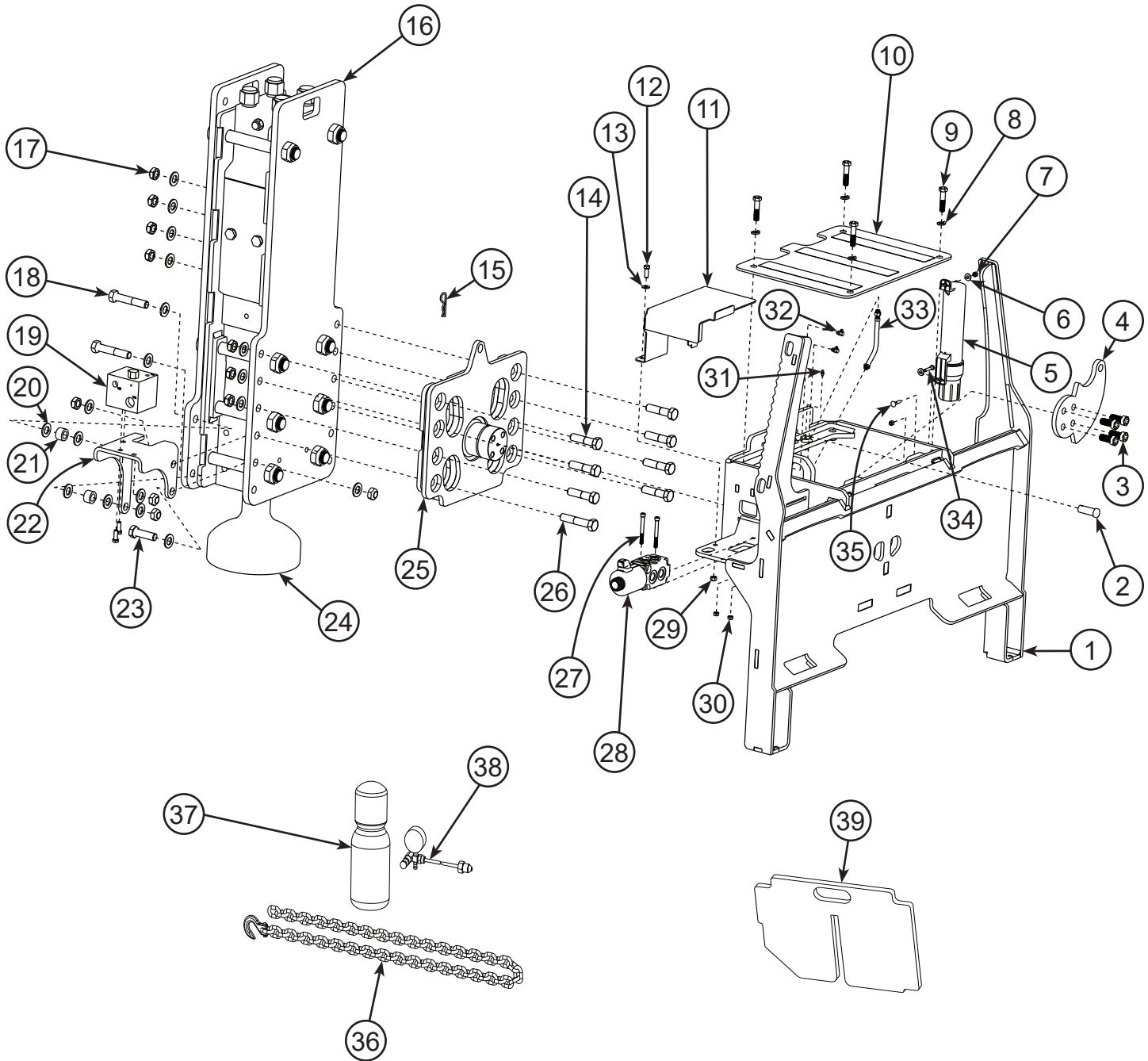

# Parts

(continued)

REF. NO.	PART NO.	DESCRIPTION	QTY.	MODEL
1	200510S	Tilt Quick Attach Weldment	1	All Models
2	21134	Clevis Pin	1	All Models
3	236018	Bolt (5/8"-18 x 1.5", Gr. 8)	4	All Models
4	200517	Tilt Stop Plate	1	All Models
5	21258	Operator's Manual Canister	1	All Models
6	21056	1/4" Flat Washer	2	All Models
7	10195	Toplock Nut (1/4"-20)	2	All Models
8	973	1/2" Lock Washer	4	All Models
9	206055	Bolt (1/2"-13 x 2.25", Gr. 5)	4	All Models
10	200066S	Cover Plate	1	All Models
11	230093S	Diverter Cover	1	All Models
12	21157	Bolt (3/8"-16 x 1", Gr. 2)	3	All Models
13	2178	3/8" Flat Washer	1	All Models
14	206089	Bolt (3/4"-10 x 3", Gr. 8)	7	All Models
15	176028	Hairpin Cotter	1	All Models
16	200080	Clamp Plate Assembly	1	T7
	180056	Clamp Plate Assembly	1	T8-RR
17	10268	Toplock Nut (3/4"-10)	11	All Models
18	216009	Bolt (3/4"-10 x 4", Gr. 8)	2	All Models
19	206012	Hydraulic Manifold	1	T7
	206013	Hydraulic Manifold	1	T8-RR
20	10267	3/4" Flat Washer	18	All Models
21	210062	Boss	1	All Models
22	230092	Manifold Bracket	1	T7
	200519	Manifold Bracket	1	T8-RR
23	206088	Bolt (3/4"-10 x 2.5", Gr. 8)	1	All Models
24	*varies	Driving Tool (see <i>Parts: Driving Tools</i> )		All Models
25	230090	Tilt Plate	1	All Models
26	216011	Bolt (3/4"-10 x 3.75", Gr. 8)	1	All Models
27	21158	Socket Heat Bolt (5/16"-18 x 3")	2	All Models
28	21128	Diverter Valve	1	All Models
29	10412	Toplock Nut (3/8"-16)	1	All Models
30	21159	Toplock Nut (5/16"-18)	2	All Models
31	35220	Grease Fitting	1	All Models
32	246015	Grease Fitting, 90°	2	All Models
33	236066	Grease Whip	1	All Models
34	206046	Bolt (1/4"-20 x 1.25", Gr. 5)	1	All Models
35	206094	Carriage Bolt (1/4"-20 x 1.25", Gr. 5)	1	All Models
36	216003	Post Pulling Chain	1	All Models
37	206101	Nitrogen Cylinder	1	All Models
38	206102	Nitrogen Gas Charge Kit	1	All Models
39	*200067	Ballast Plate (single ballast plate)	1	All Models

\* Not included with base model.

# Parts

# ⚠️ WARNING

Main Assembly w/ Grapple  
& Tilt Skid-Steer Mount

This product can expose you to chemicals known to the State of California to cause cancer and birth defects or other reproductive harm. For more information go to [www.P65Warnings.ca.gov/product](http://www.P65Warnings.ca.gov/product).

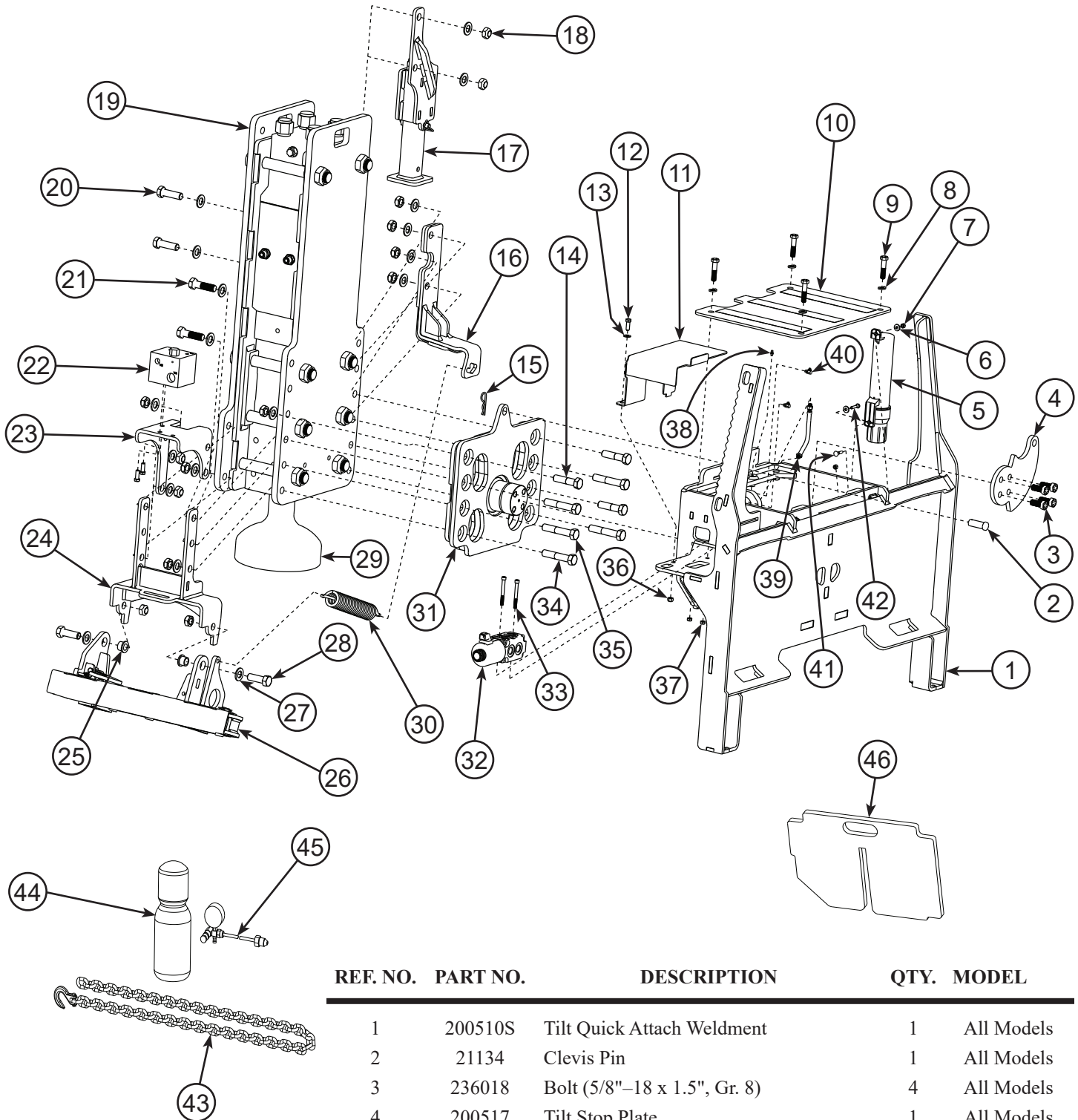

REF. NO.	PART NO.	DESCRIPTION	QTY.	MODEL
1	200510S	Tilt Quick Attach Weldment	1	All Models
2	21134	Clevis Pin	1	All Models
3	236018	Bolt (5/8"-18 x 1.5", Gr. 8)	4	All Models
4	200517	Tilt Stop Plate	1	All Models
5	21258	Operator's Manual Canister	1	All Models
6	21056	1/4" Flat Washer	2	All Models
7	10195	Toplock Nut (1/4"-20)	2	All Models
8	973	1/2" Lock Washer	4	All Models
9	206055	Bolt (1/2"-13 x 2.25", Gr. 5)	4	All Models

# Parts

(continued)

REF. NO.	PART NO.	DESCRIPTION	QTY.	MODEL
10	200066S	Cover Plate	1	All Models
11	230093S	Diverter Cover	1	All Models
12	21157	Bolt (3/8"-16 x 1", Gr. 2)	3	All Models
13	2178	3/8" Flat Washer	1	All Models
14	206089	Bolt (3/4"-10 x 3", Gr. 8)	3	All Models
15	176028	Hairpin Cotter	1	All Models
16	200580	Spring Mount Weldment	1	All Models
17	210010	Kick Stand Assembly	1	All Models
18	10268	Toplock Nut (3/4"-10)	14	All Models
19	200080	Clamp Plate Assembly	1	T7
	180056	Clamp Plate Assembly	1	T8-RR
20	206088	Bolt (3/4"-10 x 2.5", Gr. 8)	2	All Models
21	216008	Bolt (3/4"-10 x 2.75", Gr. 8)	2	All Models
22	206012	Hydraulic Manifold	1	T7
	206013	Hydraulic Manifold	1	T8-RR
23	230092	Manifold Bracket	1	T7
	200519	Manifold Bracket	1	T8-RR
24	200565	Grapple Mount	1	T7
	200570	Grapple Mount	1	T8-RR
25	206095	Grapple Bushing	2	All Models
26	200221	Grapple Assembly	1	T7
	200220	Grapple Assembly	1	T8-RR
27	10267	3/4" Flat Washer	18	All Models
28	9037	Bolt (3/4"-10 x 2.25", Gr. 8)	2	All Models
29	*varies	Driving Tool (see <i>Parts: Driving Tools</i> )		All Models
30	206090	Grapple Spring	1	All Models
31	230090	Tilt Plate	1	All Models
32	21128	Diverter Valve	1	All Models
33	21158	Socket Head Bolt (5/16"-18 x 3")	2	All Models
34	216011	Bolt (3/4"-10 x 3.75", Gr. 8)	1	All Models
35	216009	Bolt (3/4"-10 x 4", Gr. 8)	4	All Models
36	10412	Toplock Nut (3/8"-16)	1	All Models
37	21159	Toplock Nut (5/16"-18)	2	All Models
38	35220	Grease Fitting	1	All Models
39	236066	Grease Whip	1	All Models
40	246015	Grease Fitting, 90°	2	All Models
41	206094	Carriage Bolt (1/4"-20 x 1.25", Gr. 5)	1	All Models
42	206046	Bolt (1/4"-20 x 1.25", Gr. 5)	1	All Models
43	216003	Post Pulling Chain	1	All Models
44	206101	Nitrogen Cylinder	1	All Models
45	206102	Nitrogen Gas Charge Kit	1	All Models
46	*200067	Ballast Plate (single ballast plate)	1	All Models

\* Not included with base model.

# Parts

# ⚠️ WARNING

Main Assembly Backhoe &  
Excavator Mount

This product can expose you to chemicals known to the State of California to cause cancer and birth defects or other reproductive harm. For more information go to [www.P65Warnings.ca.gov/product](http://www.P65Warnings.ca.gov/product).

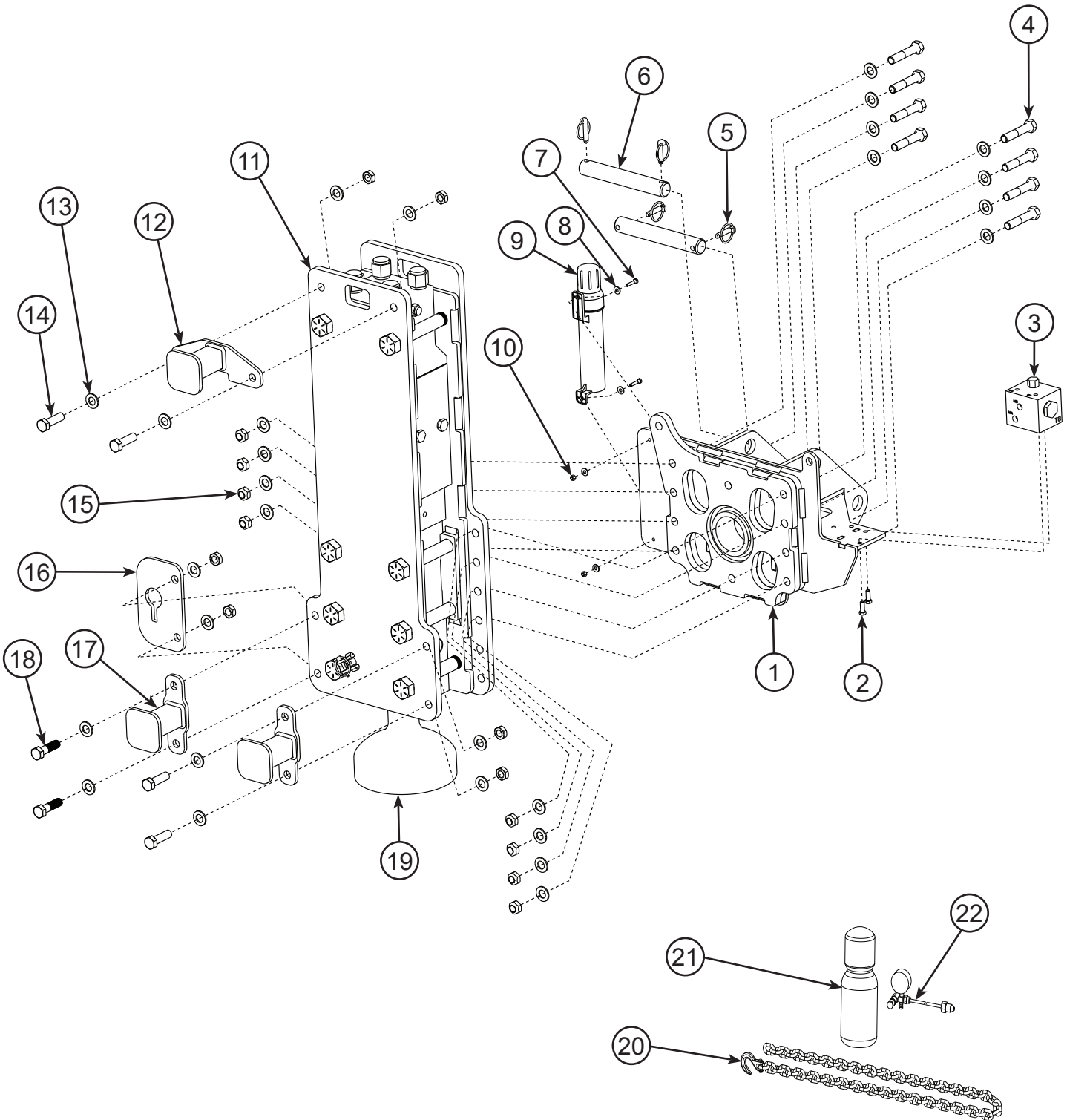

# Parts

(continued)

REF. NO.	PART NO.	DESCRIPTION	QTY.	MODEL
1	210045S	Intermediate Weldment	1	All Models
2	21157	Bolt (3/8"-16 x 1", Gr. 2)	2	All Models
3	206012	Hydraulic Manifold	1	T7
	206013	Hydraulic Manifold	1	T8-RR
4	216011	Bolt (3/4"-10 x 3.75", Gr. 8)	8	All Models
5	7524	Klik Pin Assembly	4	All Models
6	230125	Pin, 1.5" x 10.25"	2	All Models
7	206046	Bolt (1/4"-20 x 1.25", Gr. 5)	2	All Models
8	21056	1/4" Flat Washer	4	All Models
9	21258	Operator's Manual Canister	1	All Models
10	10195	Toplock Nut (1/4"-20)	2	All Models
11	200080	Clamp Plate Assembly	1	T7
	180056	Clamp Plate Assembly	1	T8-RR
12	210060	Upper Foot	1	All Models
13	10267	3/4" Flat Washer	28	All Models
14	206088	Bolt (3/4"-10 x 2.5", Gr. 8)	4	All Models
15	10268	Toplock Nut (3/4"-10)	14	All Models
16	210064	Chain Hook	1	All Models
17	210055	Lower Foot	2	All Models
18	216008	Bolt (3/4"-10 x 2.75", Gr. 8)	2	All Models
19	*varies	Driving Tool (see <i>Parts: Driving Tools</i> )		All Models
20	216003	Post Pulling Chain	1	All Models
21	206101	Nitrogen Cylinder	1	All Models
22	206102	Nitrogen Gas Charge Kit	1	All Models

\* Not included with base model.

# Parts

# ⚠️ WARNING

Main Assembly w/ Grapple  
Backhoe & Excavator  
Mount

This product can expose you to chemicals known to the State of California to cause cancer and birth defects or other reproductive harm. For more information go to [www.P65Warnings.ca.gov/product](http://www.P65Warnings.ca.gov/product).

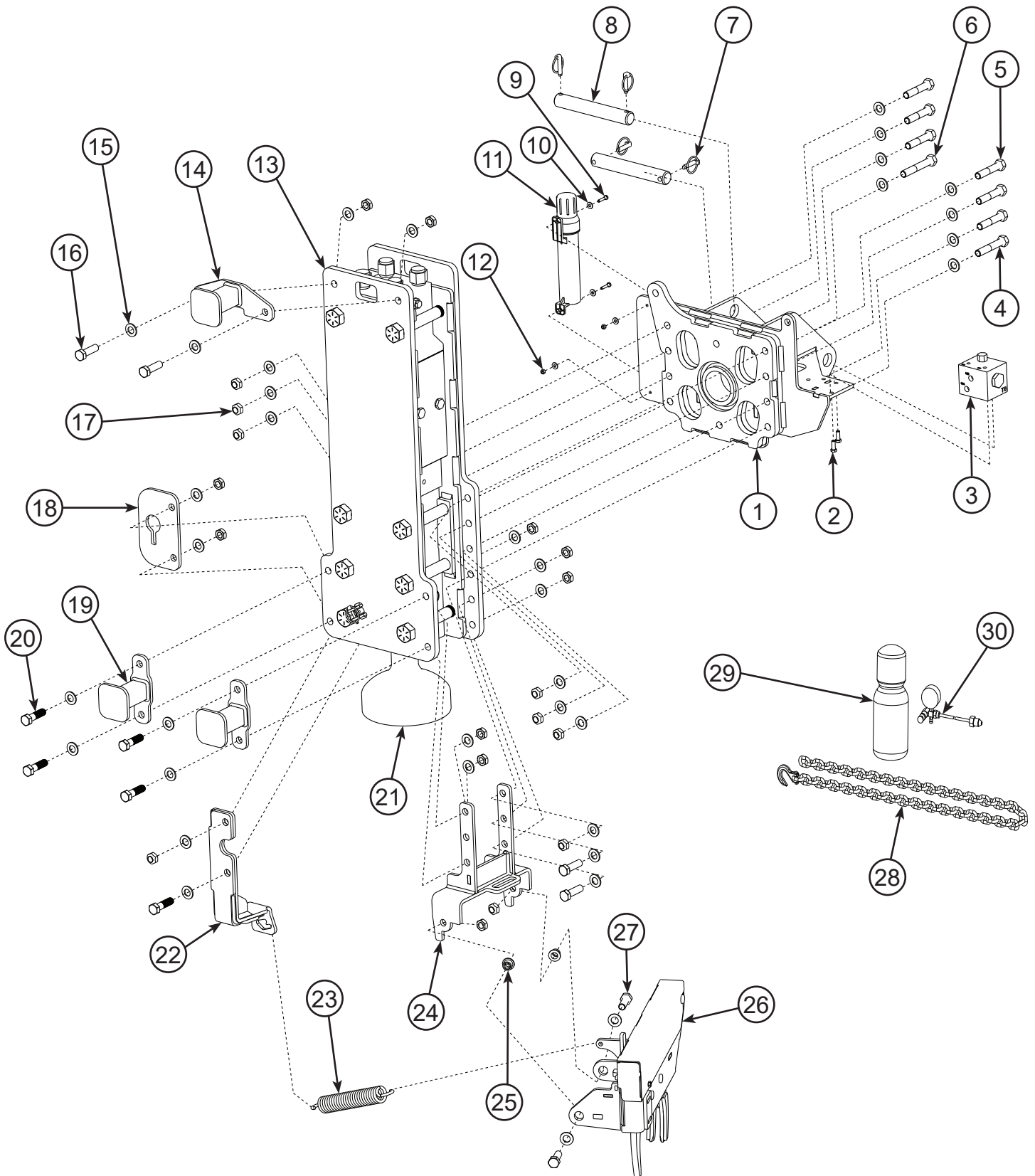

# Parts

(continued)

REF. NO.	PART NO.	DESCRIPTION	QTY.	MODEL	
	1	210045S	Intermediate Weldment	1	All Models
	2	21157	Bolt (3/8"-16 x 1", Gr. 2)	2	All Models
	3	206012	Hydraulic Manifold	1	T7
		206013	Hydraulic Manifold	1	T8-RR
	4	186061	Bolt (3/4"-10 x 4.25", Gr. 8)	1	All Models
	5	216011	Bolt (3/4"-10 x 3.75", Gr. 8)	6	All Models
	6	216010	Bolt (3/4"-10 x 4.75", Gr. 8)	1	All Models
	7	7524	Klik Pin Assembly	4	All Models
	8	230125	Pin, 1.5" x 10.25"	2	All Models
	9	206046	Bolt (1/4"-20 x 1.25", Gr. 5)	2	All Models
	10	21056	1/4" Flat Washer	4	All Models
	11	21258	Operator's Manual Canister	1	All Models
	12	10195	Toplock Nut (1/4"-20)	2	All Models
	13	200080	Clamp Plate Assembly	1	T7
		180056	Clamp Plate Assembly	1	T8-RR
	14	210060	Upper Foot	1	All Models
	15	10267	3/4" Flat Washer	36	All Models
	16	206088	Bolt (3/4"-10 x 2.5", Gr. 8)	4	All Models
	17	10268	Toplock Nut (3/4"-10)	19	All Models
	18	210064	Chain Hook	1	All Models
	19	210055	Lower Foot	2	All Models
	20	216008	Bolt (3/4"-10 x 2.75", Gr. 8)	5	All Models
	21	*varies	Driving Tool (see <i>Parts: Driving Tools</i> )		All Models
	22	200580	Spring Mount Weldment	1	All Models
	23	206090	Grapple Spring	1	All Models
	24	200565	Grapple Mount	1	T7
		200570	Grapple Mount	1	T8-RR
	25	206095	Grapple Bushing	2	All Models
	26	200221	Grapple Assembly	1	T7
		200220	Grapple Assembly	1	T8-RR
	27	9037	Bolt (3/4"-10 x 2.25", Gr. 8)	2	All Models
	28	216003	Post Pulling Chain	1	All Models
	29	206101	Nitrogen Cylinder	1	All Models
	30	206102	Nitrogen Gas Charge Kit	1	All Models

\* Not included with base model.

# Parts

Main Assembly w/ Tilt  
Backhoe & Excavator  
Mount

# ! WARNING

This product can expose you to chemicals known to the State of California to cause cancer and birth defects or other reproductive harm. For more information go to [www.P65Warnings.ca.gov/product](http://www.P65Warnings.ca.gov/product).

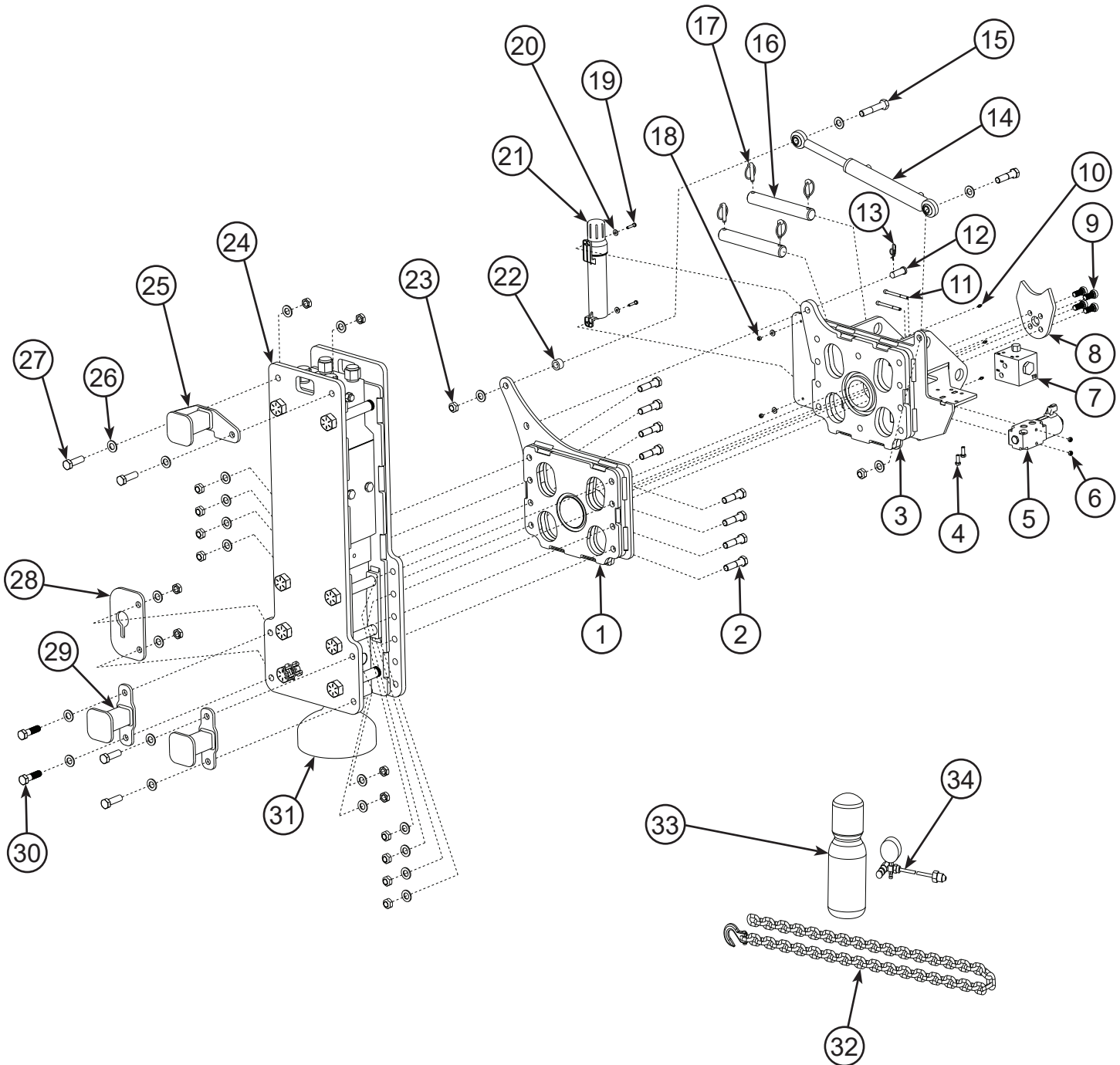

# Parts

(continued)

REF. NO.	PART NO.	DESCRIPTION	QTY.	MODEL	
	1	210065S	Tilt Plate	1	All Models
	2	206089	Bolt (3/4"-10 x 3", Gr. 8)	9	All Models
	3	210045S	Intermediate Weldment	1	All Models
	4	21157	Bolt (3/8"-16 x 1", Gr. 2)	2	All Models
	5	21128	Diverter Valve	1	All Models
	6	21159	Toplock Nut (5/16"-18)	2	All Models
	7	206012	Hydraulic Manifold	1	T7
		206013	Hydraulic Manifold	1	T8-RR
	8	210063S	Tilt Stop Plate	1	All Models
	9	236018	Bolt (5/8"-18 x 1.5", Gr. 8)	4	All Models
	10	35220	Grease Fitting	3	All Models
	11	216028	Socket Head Bolt (5/16"-18 x 3.5")	2	All Models
	12	21134	Clevis Pin	1	All Models
	13	21078	Rue Clip	1	All Models
	14	210074	Tilt Cylinder Weldment	1	All Models
	15	216009	Bolt (3/4"-10 x 4", Gr. 8)	1	All Models
	16	230125	Pin, 1.5" x 10.25"	2	All Models
	17	7524	Klik Pin Assembly	4	All Models
	18	10195	Toplock Nut (1/4"-20)	2	All Models
	19	206046	Bolt (1/4"-20 x 1.25", Gr. 5)	2	All Models
	20	21056	1/4" Flat Washer	4	All Models
	21	21258	Operator's Manual Canister	1	All Models
	22	210062	Boss	1	All Models
	23	10268	Toplock Nut (3/4"-10)	16	All Models
	24	200080	Clamp Plate Assembly	1	T7
		180056	Clamp Plate Assembly	1	T8-RR
	25	210060	Upper Foot	1	All Models
	26	10267	3/4" Flat Washer	24	All Models
	27	206088	Bolt (3/4"-10 x 2.5", Gr. 8)	4	All Models
	28	210064	Chain Hook	1	All Models
	29	210055	Lower Foot	2	All Models
	30	216008	Bolt (3/4"-10 x 2.75", Gr. 8)	2	All Models
	31	*varies	Driving Tool (see <i>Parts: Driving Tools</i> )		All Models
	32	216003	Post Pulling Chain	1	All Models
	33	206101	Nitrogen Cylinder	1	All Models
	34	206102	Nitrogen Gas Charge Kit	1	All Models

\* Not included with base model.

# Parts

Main Assembly  
w/ Grapple & Tilt Backhoe  
& Excavator Mount

# ! WARNING

This product can expose you to chemicals known to the State of California to cause cancer and birth defects or other reproductive harm. For more information go to [www.P65Warnings.ca.gov/product](http://www.P65Warnings.ca.gov/product).

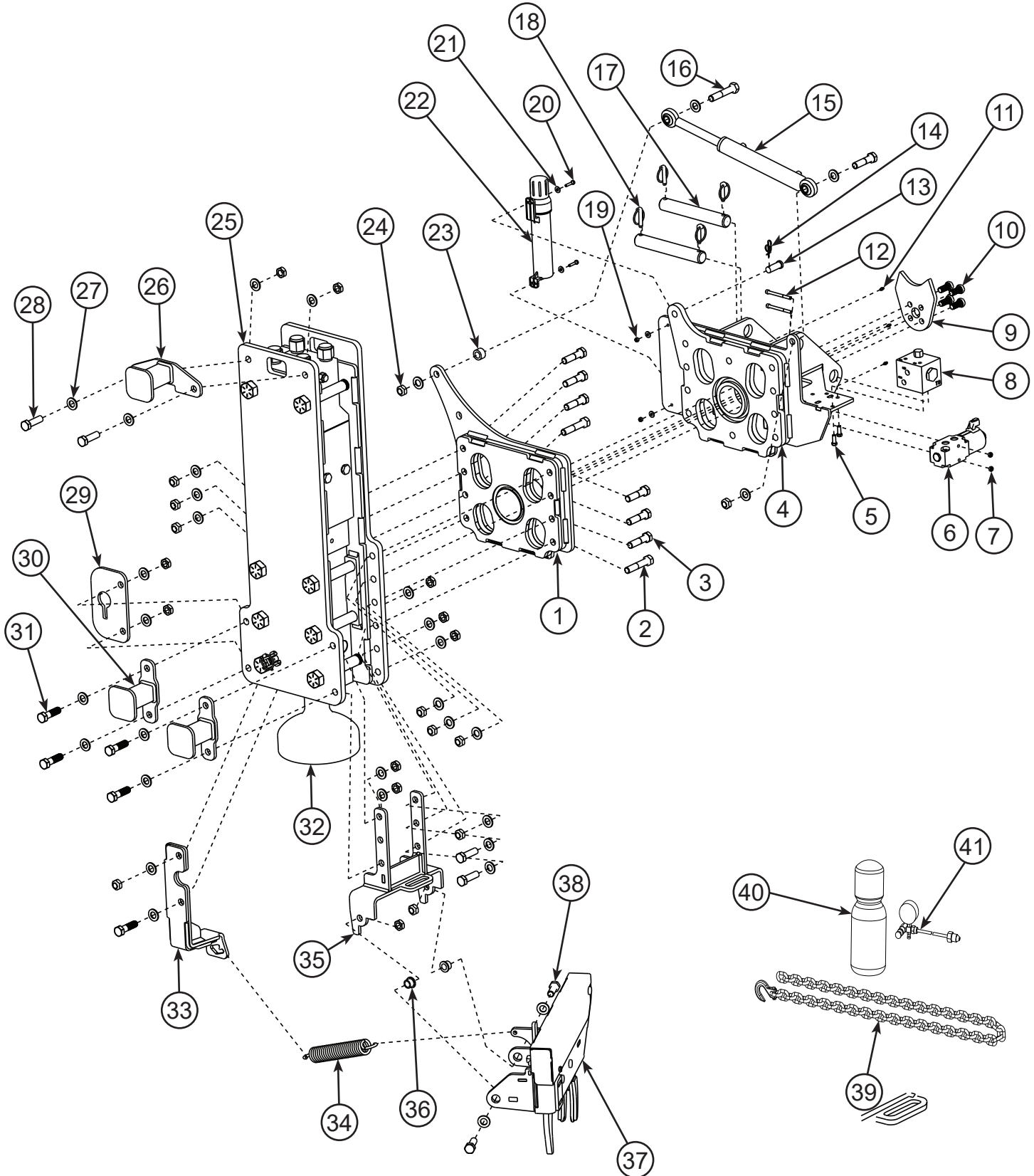

# Parts

(continued)

REF. NO.	PART NO.	DESCRIPTION	QTY.	MODEL
1	210065S	Tilt Plate	1	All Models
2	216011	Bolt (3/4"-10 x 3.75", Gr. 8)	2	All Models
3	206089	Bolt (3/4"-10 x 3", Gr. 8)	7	All Models
4	210045S	Intermediate Weldment	1	All Models
5	21157	Bolt (3/8"-16 x 1", Gr. 2)	2	All Models
6	21128	Diverter Valve	1	All Models
7	21159	Toplock Nut (5/16"-18)	2	All Models
8	206012	Hydraulic Manifold	1	T7
	206013	Hydraulic Manifold	1	T8-RR
9	210063S	Tilt Stop Plate	1	All Models
10	236018	Bolt (5/8"-18 x 1.5", Gr. 8)	4	All Models
11	35220	Grease Fitting	3	All Models
12	216028	Socket Head Bolt (5/16"-18 x 3.5")	2	All Models
13	21134	Clevis Pin	1	All Models
14	21078	Rue Clip	1	All Models
15	210074	Tilt Cylinder Weldment	1	All Models
16	216009	Bolt (3/4"-10 x 4", Gr. 8)	1	All Models
17	230125	Pin, 1.5" x 10.25"	2	All Models
18	7524	Klik Pin Assembly	4	All Models
19	10195	Toplock Nut (1/4"-20)	2	All Models
20	206046	Bolt (1/4"-20 x 1.25", Gr. 5)	2	All Models
21	21056	1/4" Flat Washer	4	All Models
22	21258	Operator's Manual Canister	1	All Models
23	210062	Boss	1	All Models
24	10268	Toplock Nut (3/4"-10)	21	All Models
25	200080	Clamp Plate Assembly	1	T7
	180056	Clamp Plate Assembly	1	T8-RR
26	210060	Upper Foot	1	All Models
27	10267	3/4" Flat Washer	32	All Models
28	206088	Bolt (3/4"-10 x 2.5", Gr. 8)	4	All Models
29	210064	Chain Hook	1	All Models
30	210055	Lower Foot	2	All Models
31	216008	Bolt (3/4"-10 x 2.75", Gr. 8)	5	All Models
32	*varies	Driving Tool (see <i>Parts: Driving Tools</i> )		All Models
33	200580	Spring Mount Weldment	1	All Models
34	206090	Grapple Spring	1	All Models
35	200565	Grapple Mount	1	T7
	200570	Grapple Mount	1	T8-RR
36	206095	Grapple Bushing	2	All Models
37	200221	Grapple Assembly	1	T7
	200220	Grapple Assembly	1	T8-RR
38	9037	Bolt (3/4"-10 x 2.25", Gr. 8)	2	All Models
39	216003	Post Pulling Chain	1	All Models
40	206101	Nitrogen Cylinder	1	All Models
41	206102	Nitrogen Gas Charge Kit	1	All Models

\* Not included with base model.

# Parts

## Clamp Plate Assembly

# ⚠️ WARNING

This product can expose you to chemicals known to the State of California to cause cancer and birth defects or other reproductive harm. For more information go to [www.P65Warnings.ca.gov/product](http://www.P65Warnings.ca.gov/product).

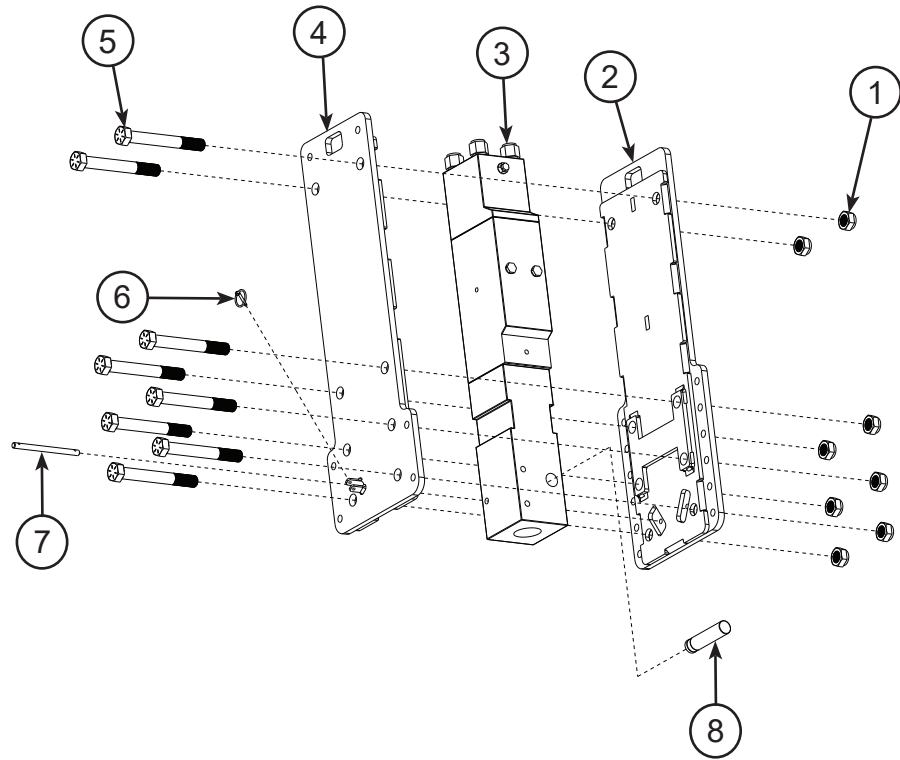

REF NO.	PART NO.	DESCRIPTION	QTY.	MODEL
1	206053	Toplock Nut (1-1/4"-12)	8	All Models
2	200090S	Back Clamp Plate	1	T7
	180057S	Back Clamp Plate	1	T8-RR
3	196068S	Power Cell	1	T7
	196075S	Power Cell	1	T8-RR
4	200085S	Front Clamp Plate	1	T7
	180080S	Front Clamp Plate	1	T8-RR
5	206093	Bolt (1-1/4"-12 x 9.5", Gr. 8)	8	T7
	206052	Bolt (1-1/4"-12 x 10", Gr. 8)	8	T8-RR
6	1185	Klik Pin Assembly	1	All Models
7	200068	Driving Tool Lock Pin	1	T7
	200075	Driving Tool Lock Pin	1	T8-RR
8	216103	Driving Tool Retention Pin	1	T7
	216126	Driving Tool Retention Pin	1	T8-RR

# Parts

## Power Cell

### **⚠ DANGER**

Release power cell nitrogen gas pressure and hydraulic oil pressure before disassembling power cell.

### **⚠ WARNING**

This product can expose you to chemicals known to the State of California to cause cancer and birth defects or other reproductive harm. For more information go to [www.P65Warnings.ca.gov/product](http://www.P65Warnings.ca.gov/product).

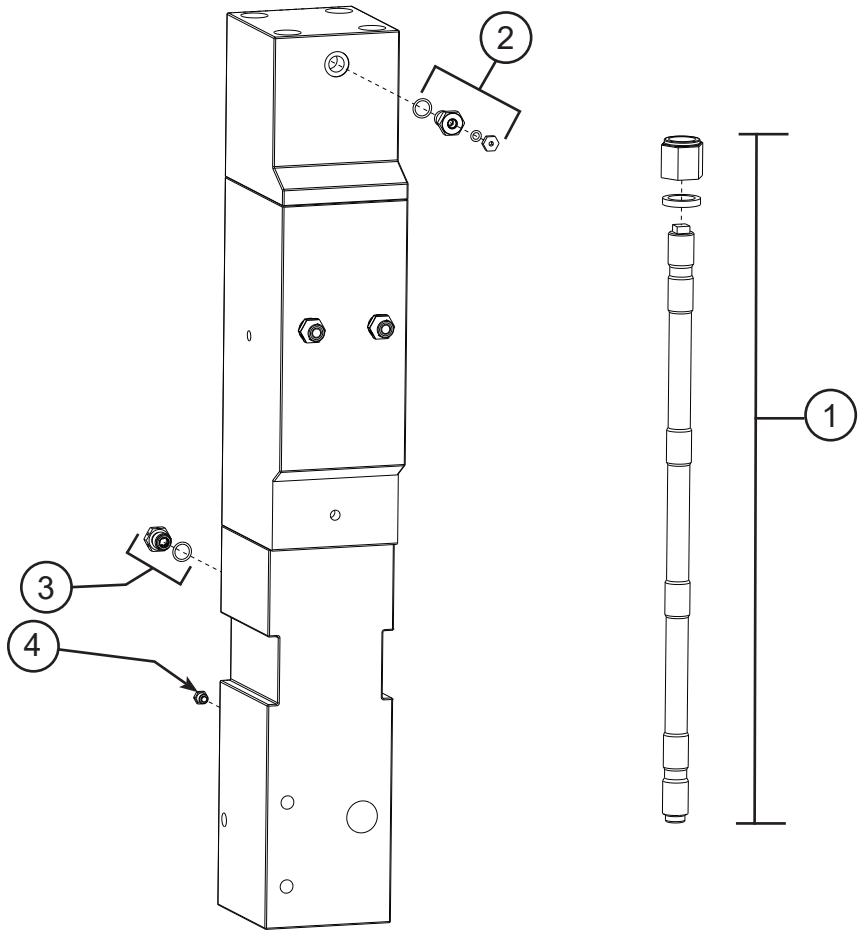

REF. NO.	PART NO.	DESCRIPTION	QTY.	MODEL
1	216087	Thru Bolt Kit	4	T7
	216114	Thru Bolt Kit	4	T8-RR
2	216106	Charging Valve Assembly	1	All Models
3	216100	Air Check Valve	1	All Models
4	216101	Grease Zerk	1	All Models
5	216104	Seal Kit (not pictured)	1	T7
	216127	Seal Kit (not pictured)	1	T8-RR

# Parts

## ⚠️ WARNING

### Grapple

This product can expose you to chemicals known to the State of California to cause cancer and birth defects or other reproductive harm. For more information go to [www.P65Warnings.ca.gov/product](http://www.P65Warnings.ca.gov/product).

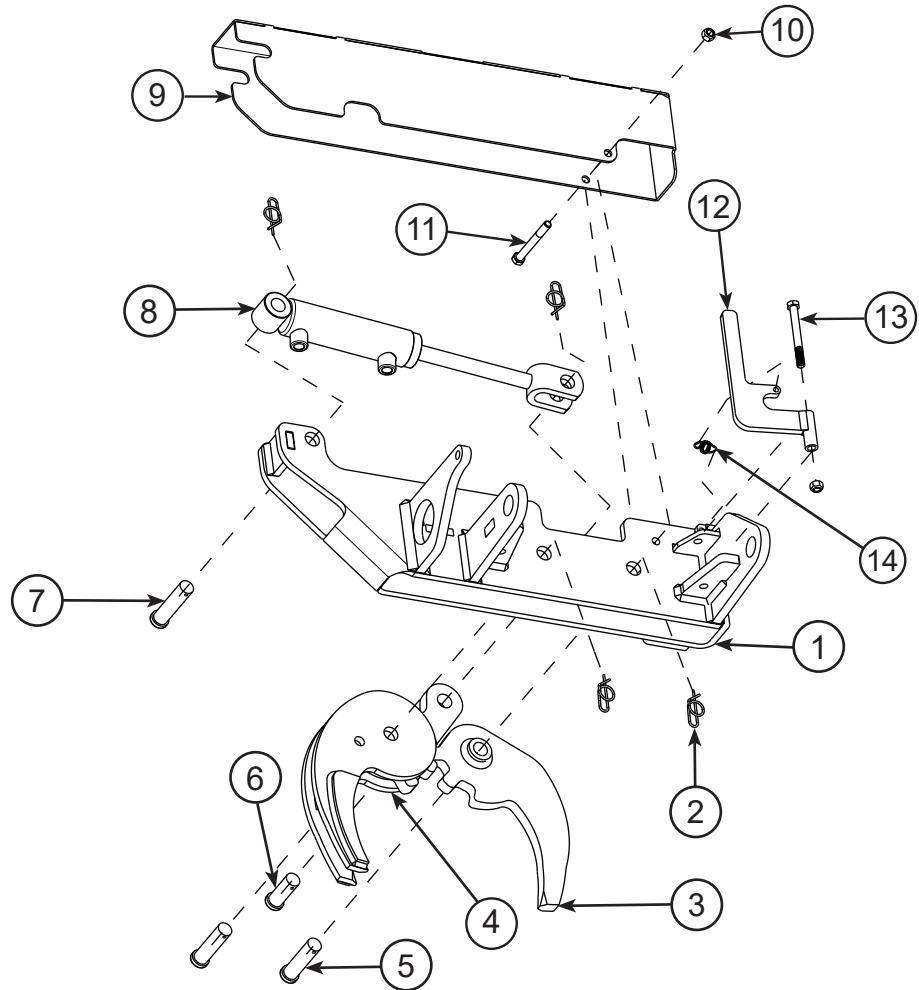

REF. NO.	PART NO.	DESCRIPTION	QTY.	MODEL
1	200585	Grapple Case	1	T7
	200225	Grapple Case	1	T8-RR
2	21078	Rue Clip	4	All Models
3	200230	Male Jaw	1	All Models
4	200232	Female Jaw	1	All Models
5	21077	Clevis Pin	2	All Models
6	21134	Clevis Pin	1	All Models
7	206092	Clevis Pin	1	All Models
8	21167	Hydraulic Cylinder Weldment	1	All Models
9	200550S	Grapple Cover	1	All Models
10	10412	Toplock Nut (3/8"-16)	2	All Models
11	10413	Bolt (3/8"-16 x 3.25", Gr. 5)	1	All Models
12	200545	Grapple Lock	1	All Models
13	3041	Bolt (3/8"-16 x 3.5", Gr. 8)	1	All Models
14	206091	Spring	1	All Models

# Parts

## Driving Tools

# ⚠️ WARNING

This product can expose you to chemicals known to the State of California to cause cancer and birth defects or other reproductive harm. For more information go to [www.P65Warnings.ca.gov/product](http://www.P65Warnings.ca.gov/product).

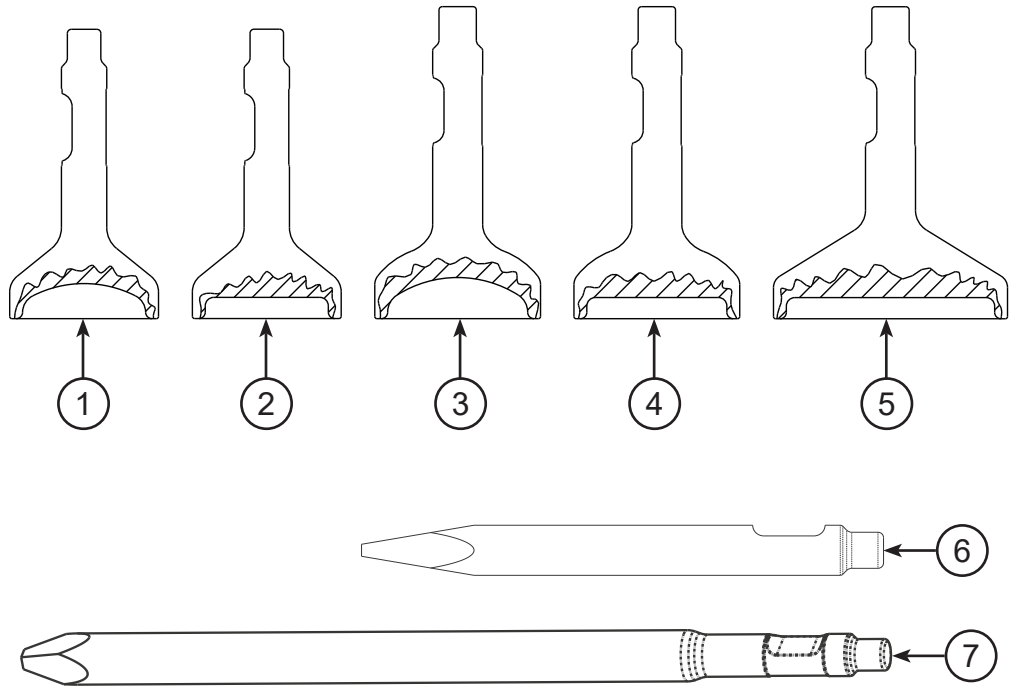

REF. NO.	PART NO.	DESCRIPTION	QTY.	MODEL
1	196067	Domed Driving Tool	1	T7
2	196067F	Flat Driving Tool	1	T7
3	196074	Domed Driving Tool	1	T8-RR
4	196074F	Flat Driving Tool	1	T8-RR
5	196074R	Railroad Tie Flat Driving Tool	1	T8-RR
6	236080	Concrete Breaker Tool	1	T7
	236082	Concrete Breaker Tool	1	T8-RR
7	236090	Rock Spike	1	T8-RR

This page is intentionally blank.

# Parts

Hydraulics  
Skid-Steer Mount

## ⚠️ WARNING

This product can expose you to chemicals known to the State of California to cause cancer and birth defects or other reproductive harm. For more information go to [www.P65Warnings.ca.gov/product](http://www.P65Warnings.ca.gov/product).

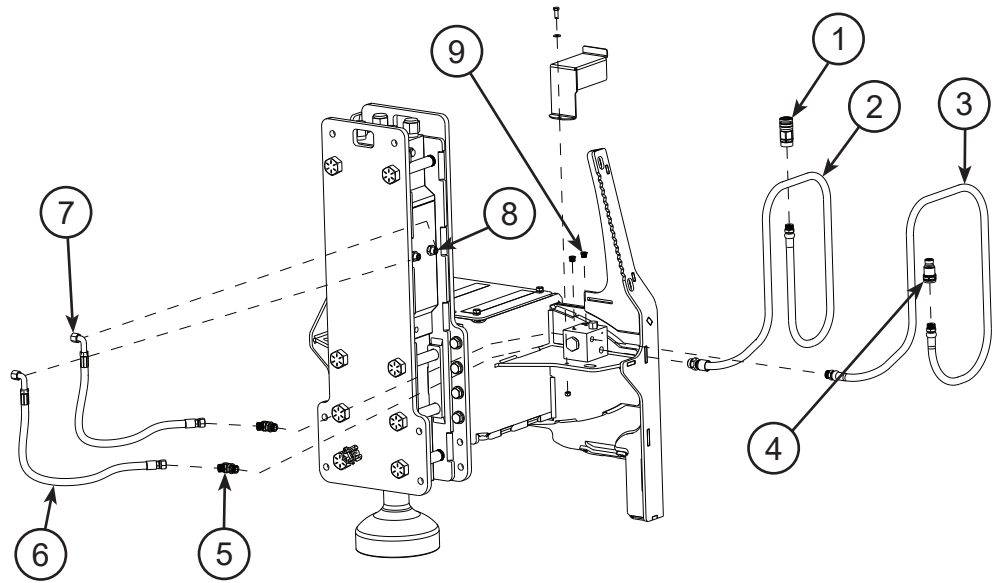

REF. NO.	PART NO.	DESCRIPTION	QTY.	MODEL
1	10049	Female Coupler (1/2" Flush-Face, ISO 16028)	1	All Models
2	206024	1/2" Hose Assembly (#10 ORB M to #12 ORB M)	1	All Models
3	206000	1/2" Hose Assembly (#10 ORB M to #10 ORB M)	1	All Models
4	10048	Male Coupler (1/2" Flush-Face, ISO 16028)	1	All Models
5	196043	Adapter, 45° (#8 ORFS M to #7/8-14 UNF-2A)	2	All Models
6	216007	1/2" Hose Assembly, 90° (#8 ORFS F to #8 ORFS F)	1	T7
	206023	1/2" Hose Assembly, 90° (#8 ORFS F to #8 ORFS F)	1	T8-RR
7	216006	1/2" Hose Assembly, 90° (#8 ORFS F to #8 ORFS F)	1	T7
	206022	1/2" Hose Assembly, 90° (#8 ORFS F to #8 ORFS F)	1	T8-RR
8	206015	Adapter (#8 BSPP M to #8 ORFS M)	2	All Models
9	21141	Plug (#6 ORB)	2	All Models

# Parts

Grapple Hydraulics w/ Tilt  
Skid-Steer Mount

## ⚠️ WARNING

This product can expose you to chemicals known to the State of California to cause cancer and birth defects or other reproductive harm. For more information go to [www.P65Warnings.ca.gov/product](http://www.P65Warnings.ca.gov/product).

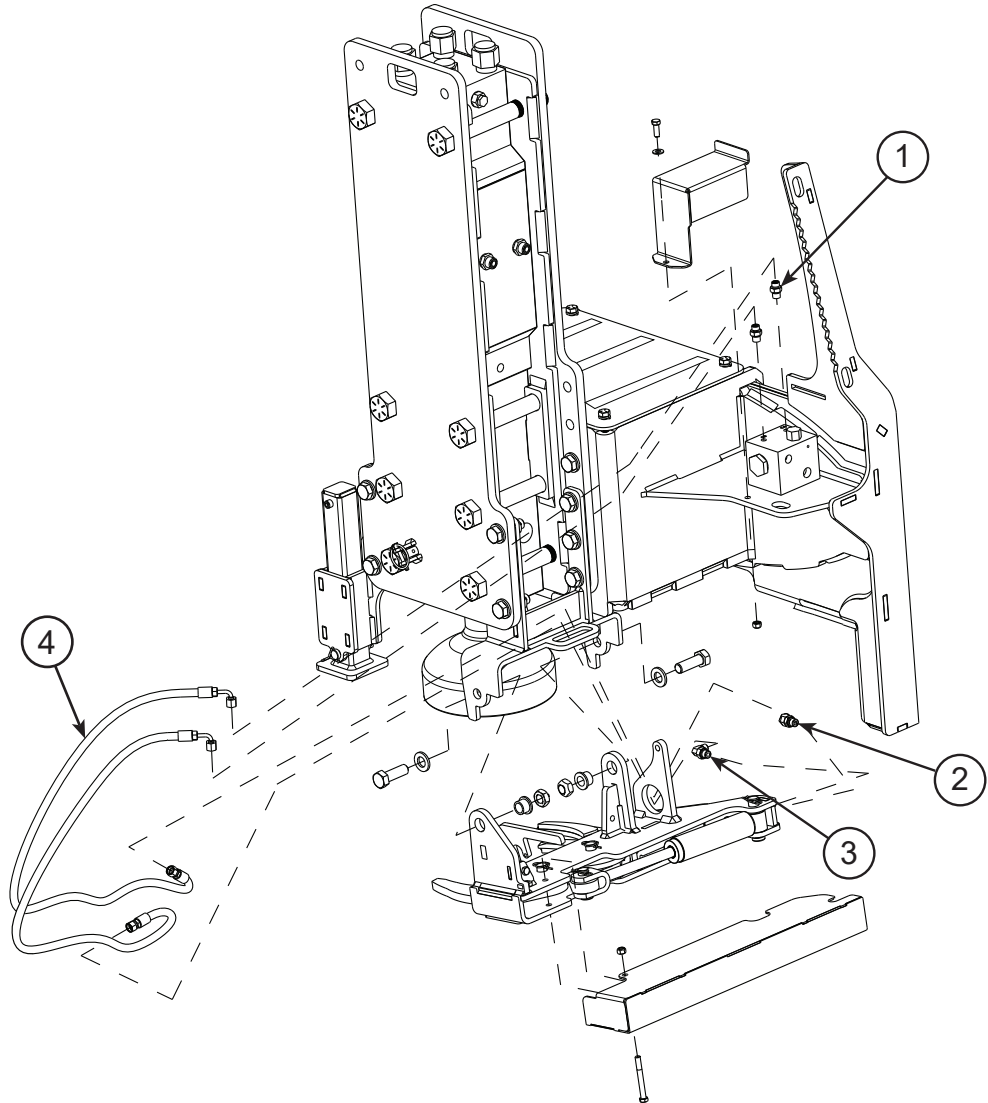

REF. NO.	PART NO.	DESCRIPTION	QTY.	MODEL
1	196045	Adapter (#4 ORFS M to #6 ORB M)	2	All Models
2	206087	Adapter, 45° (#4 ORFS M to #6 ORB M)	1	All Models
3	206014	Adapter, 90° (#4 ORFS M to #6 ORB M)	1	All Models
4	206021	1/4" Hose Assembly, 90° (# 4 ORFS F to #4 ORFS F)	2	All Models

# Parts

Grapple Hydraulics  
Non-Tilt Skid-Steer Mount

## ⚠️ WARNING

This product can expose you to chemicals known to the State of California to cause cancer and birth defects or other reproductive harm. For more information go to [www.P65Warnings.ca.gov/product](http://www.P65Warnings.ca.gov/product).

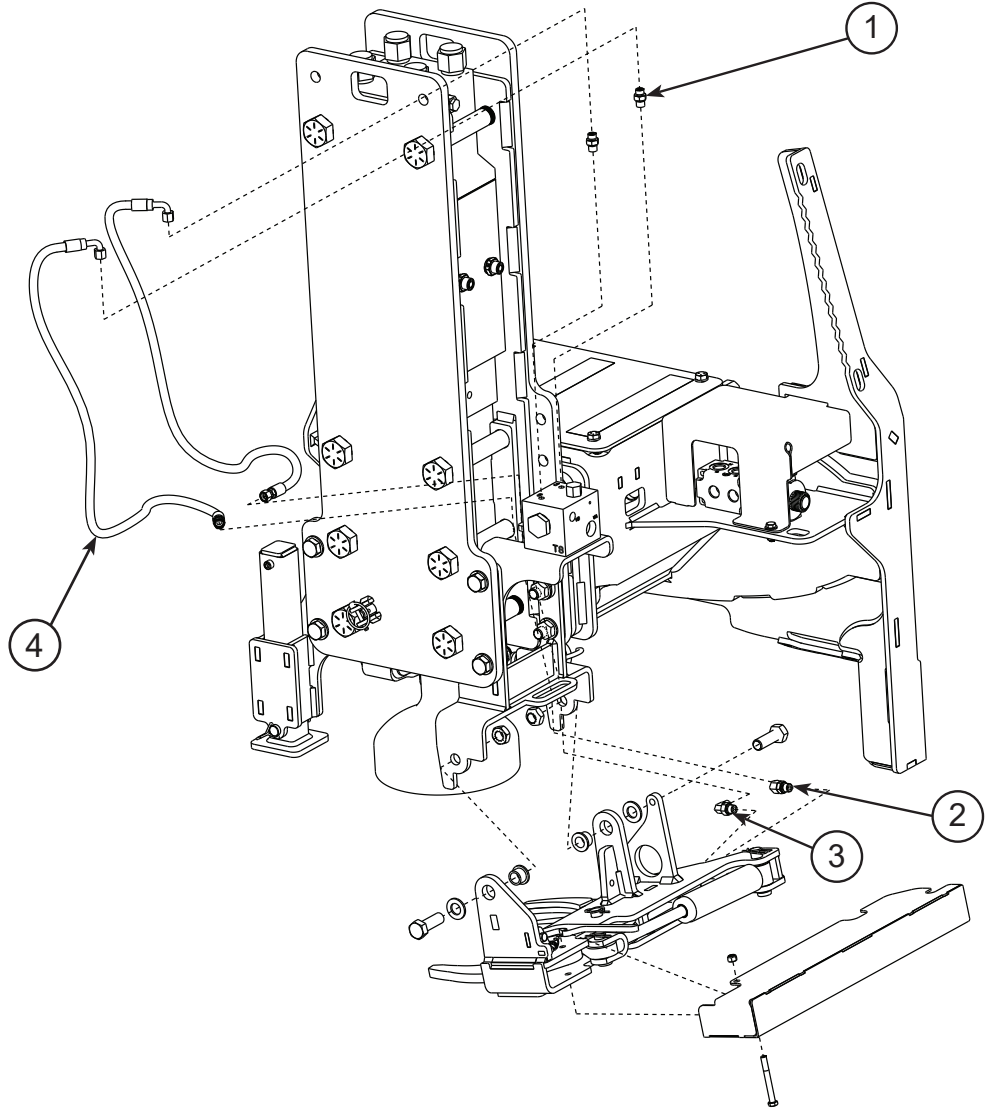

REF. NO.	PART NO.	DESCRIPTION	QTY.	MODEL
1	196045	Adapter (#4 ORFS M to #6 ORB M)	2	All Models
2	206087	Adapter, 45° (#4 ORFS M to #6 ORB M)	1	All Models
3	206014	Adapter, 90° (#4 ORFS M to #6 ORB M)	1	All Models
4	206021	1/4" Hose Assembly, 90° (# 4 ORFS F to #4 ORFS F)	2	All Models

# Parts

Tilt Hydraulics  
Skid-Steer Mount

## ⚠️ WARNING

This product can expose you to chemicals known to the State of California to cause cancer and birth defects or other reproductive harm. For more information go to [www.P65Warnings.ca.gov/product](http://www.P65Warnings.ca.gov/product).

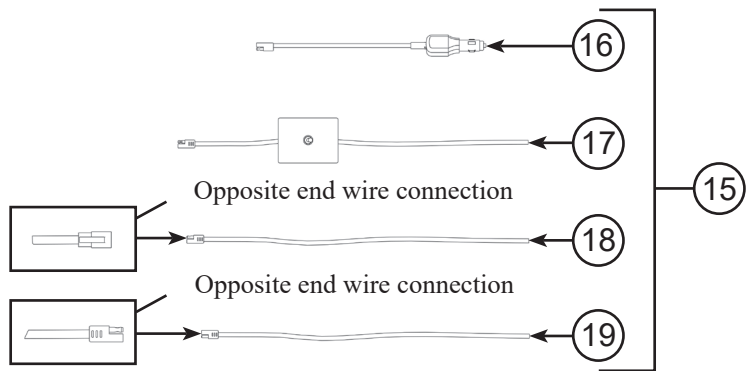
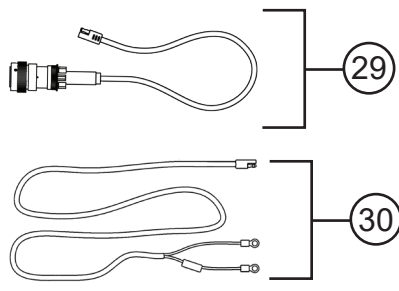
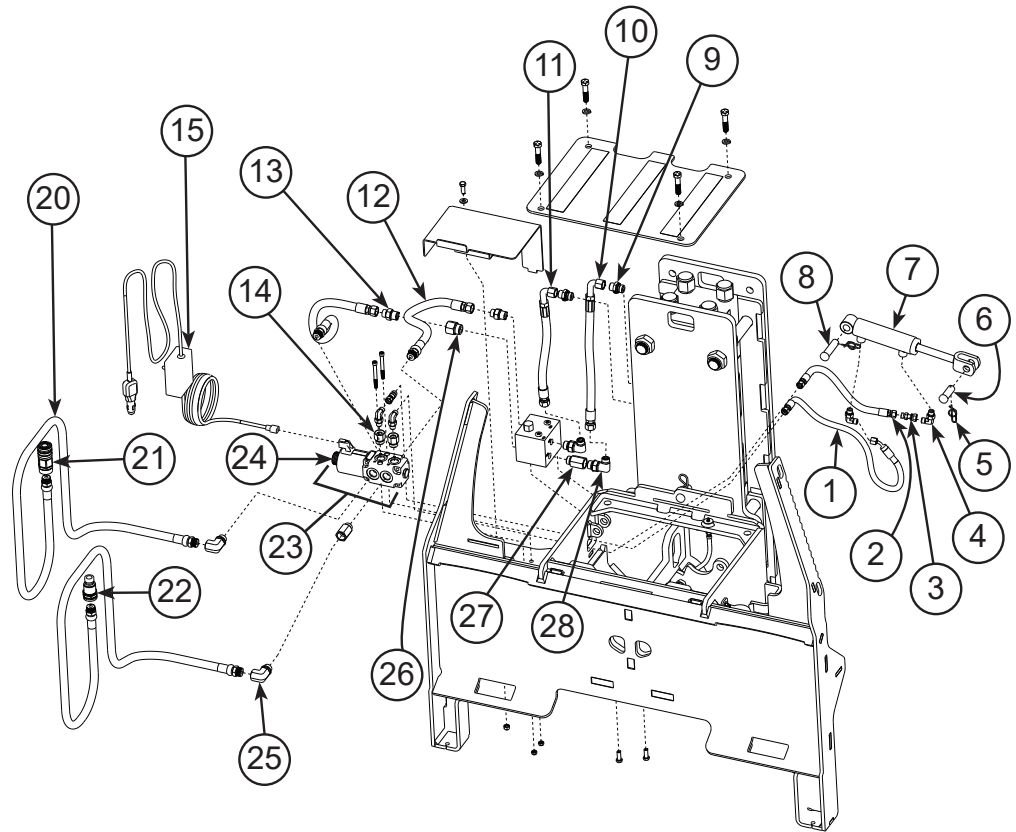

# Parts

(continued)

REF. NO.	PART NO.	DESCRIPTION	QTY.	MODEL
1	216032	1/4" Hose Assembly, 45° (#4 ORFS F to #4 ORFS F)	1	All Models
2	216031	1/4" Hose Assembly (#4 ORFS F to #4 ORFS F)	1	All Models
3	216030	Restrictor (#4 ORFS M to #4 ORFS F)	2	All Models
4	206014	Adapter, 90° (#4 ORFS M to #6 ORB M)	4	All Models
5	21078	Rue Clip	2	All Models
6	21134	Clevis Pin	1	All Models
7	21167	Hydraulic Cylinder Weldment	1	All Models
8	21077	Clevis Pin	1	All Models
9	206015	Adapter (#8 BSPP M to #8 ORFS M)	2	All Models
10	216034	1/2" Hose Assembly, 90° (# 8 ORFS F to #8 ORFS F)	1	T7
	216036	1/2" Hose Assembly, 90° (# 8 ORFS F to #8 ORFS F)	1	T8-RR
11	216035	1/2" Hose Assembly, 90° (# 8 ORFS F to #8 ORFS F)	1	T7
	216037	1/2" Hose Assembly, 90° (# 8 ORFS F to #8 ORFS F)	1	T8-RR
12	216033	1/2" Hose Assembly (# 8 ORFS F to #10 ORB M)	2	All Models
13	196044	Adapter (#8 ORFS M to #10 ORB M)	2	All Models
14	216029	Adapter (#10 ORB M to #6 ORB F)	2	All Models
15	21162	Wiring Harness (Includes REF. NOS. 16-19)	1	All Models
16	21343	Wire (12-volt Auxiliary Power)	1	All Models
17	21344	Wire (Control Switch)	1	All Models
18	21345	Wire (Solenoid)	1	All Models
19	21346	Wire (Extension)	1	All Models
20	206000	1/2" Hose Assembly (#10 ORB M to #10 ORB M)	2	All Models
21	10049	Female Coupler (1/2" Flush-Face, ISO 16028)	1	All Models
22	10048	Male Coupler (1/2" Flush-Face, ISO 16028)	1	All Models
23	21128	Diverter Valve (Includes REF. NO. 24)	1	All Models
24	21340	Diverter Valve Solenoid	1	All Models
25	216038	Adapter, 90° (#10 ORB M to #10 ORB F)	2	All Models
26	236069	Adapter (#12 ORB M to #10 ORB F)	1	All Models
27	216039	Adapter (#10 ORB M to #10 ORB F)	2	All Models
28	216026	Adapter, 90° (#8 ORFS M to #10 ORB M)	2	All Models
29	*21220	Optional Wiring Harness	1	All Models
30	*21253	Optional Wiring Harness (Battery Connection)	1	All Models

\* For PN and full description, refer to *Accessories*.

# Parts

# ⚠️ WARNING

Hydraulics Backhoe &  
Excavator Mount

This product can expose you to chemicals known to the State of California to cause cancer and birth defects or other reproductive harm. For more information go to [www.P65Warnings.ca.gov/product](http://www.P65Warnings.ca.gov/product).

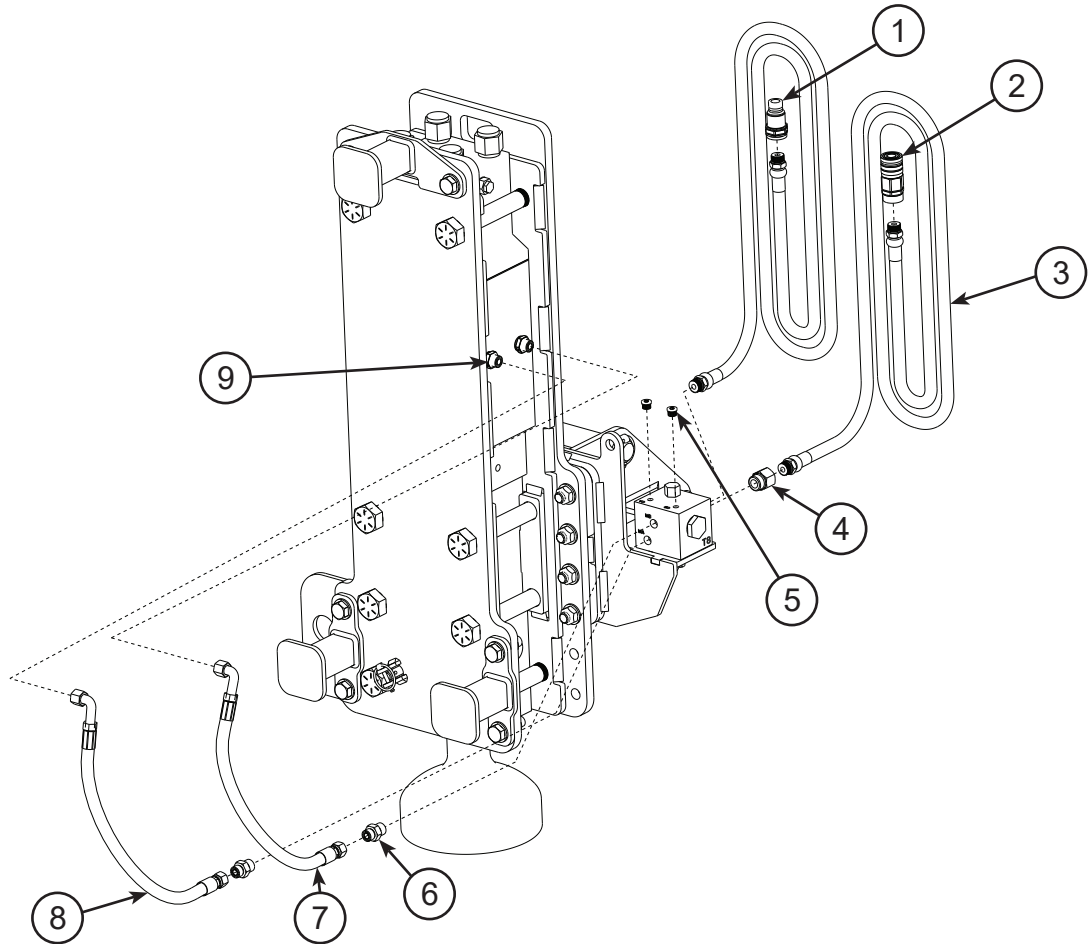

REF. NO.	PART NO.	DESCRIPTION	QTY.	MODEL
1	10048	Male coupler (1/2" Flush-Face, ISO 16028)	1	All Models
2	10049	Female Coupler (1/2" Flush-Face, ISO 16028)	1	All Models
3	216073	1/2" Hose Assembly (#10 ORB M to #10 ORB M)	2	All Models
4	236069	Adapter (#12 ORB M to #10 ORB F)	1	All Models
5	21141	Plug (#6 ORB)	2	All Models
6	196044	Adapter (#8 ORFS M to #10 ORB M)	2	All Models
7	216037	1/2" Hose Assembly, 90° (# 8 ORFS F to #8 ORFS F)	1	T7-Non-Tilt Models
	216075	1/2" Hose Assembly, 90° (# 8 ORFS F to #8 ORFS F)	1	T7-Tilt Models & T8-RR-Non-Tilt Models
	216076	1/2" Hose Assembly, 90° (# 8 ORFS F to #8 ORFS F)	1	T8-RR-Tilt Models
8	216036	1/2" Hose Assembly, 90° (# 8 ORFS F to #8 ORFS F)	1	T7-Non-Tilt Models
	216074	1/2" Hose Assembly, 90° (# 8 ORFS F to #8 ORFS F)	1	T7-Tilt Models & T8-RR-Non-Tilt Models
	216006	1/2" Hose Assembly, 90° (#8 ORFS F to #8 ORFS F)	1	T8-RR-Tilt Models
9	206015	Adapter (#8 BSPP M to #8 ORFS M)	2	All Models

## Parts

Grapple Hydraulics  
Backhoe & Excavator  
Mount

## ! WARNING

This product can expose you to chemicals known to the State of California to cause cancer and birth defects or other reproductive harm. For more information go to [www.P65Warnings.ca.gov/product](http://www.P65Warnings.ca.gov/product).

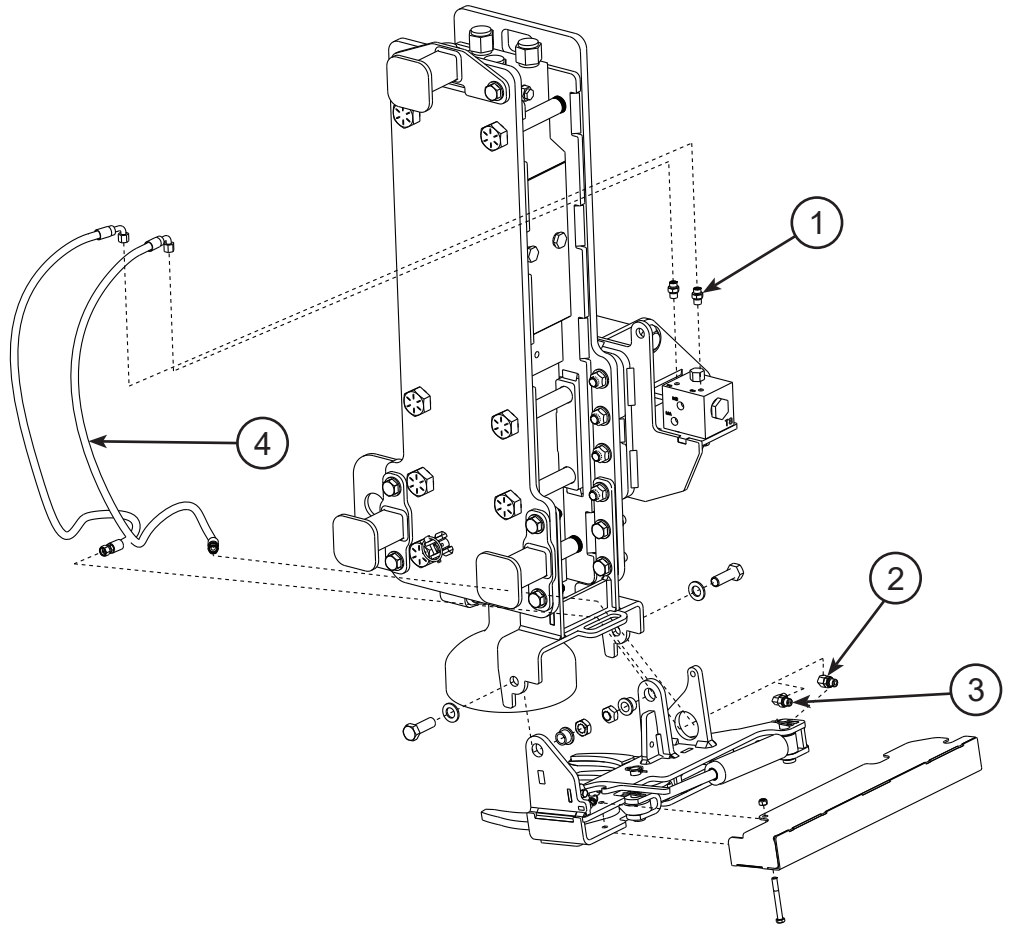

REF. NO.	PART NO.	DESCRIPTION	QTY.	MODEL
1	196045	Adapter (#4 ORFS M to #6 ORB M)	2	All Models
2	206087	Adapter, 45° (#4 ORFS M to #6 ORB M)	1	All Models
3	206014	Adapter, 90° (#4 ORFS M to #6 ORB M)	1	All Models
4	206021	1/4" Hose Assembly, 90° (# 4 ORFS F to #4 ORFS F)	2	All Models

# Parts

Tilt Hydraulics Backhoe &  
Excavator Mount

## ⚠️ WARNING

This product can expose you to chemicals known to the State of California to cause cancer and birth defects or other reproductive harm. For more information go to [www.P65Warnings.ca.gov/product](http://www.P65Warnings.ca.gov/product).

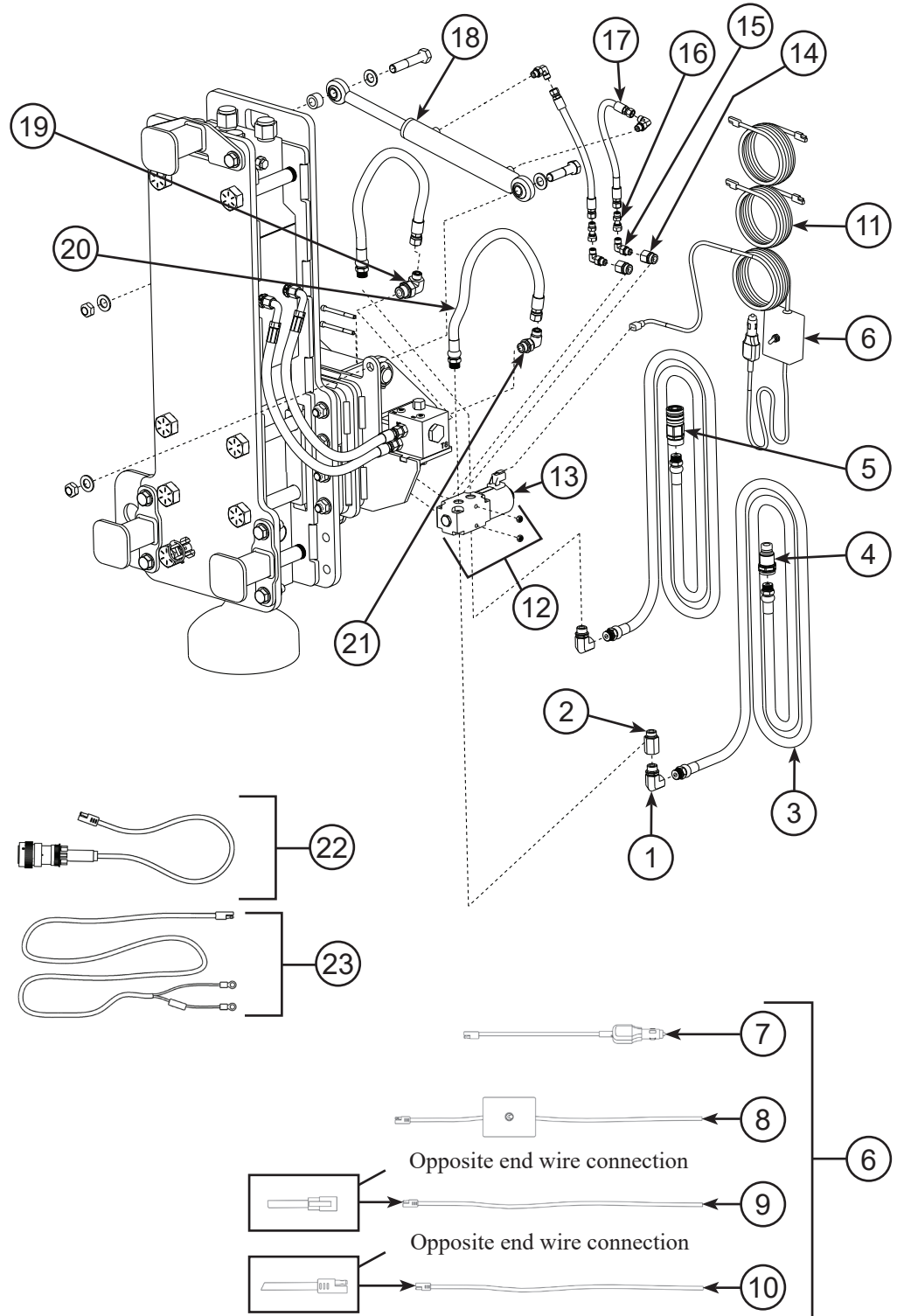

# Parts

(continued)

REF. NO.	PART NO.	DESCRIPTION	QTY.	MODEL
1	216038	Adapter, 90° (#10 ORB M to #10 ORB F)	2	All Models
2	216039	Adapter (#10 ORB M to #10 ORB F)	1	All Models
3	216073	1/2" Hose Assembly (#10 ORB M to #10 ORB M)	2	All Models
4	10048	Male Coupler (1/2" Flush-Face, ISO 16028)	1	All Models
5	10049	Female Coupler (1/2" Flush-Face, ISO 16028)	1	All Models
6	21162	Wiring Harness (Includes REF. NOS. 7-10)	1	All Models
7	21343	Wire (12-volt Auxiliary Power)	1	All Models
8	21344	Wire (Control Switch)	1	All Models
9	21345	Wire (Solenoid)	1	All Models
10	21346	Wire (Extension)	1	All Models
11	21346	Wire (Extension)	2	All Models
12	21128	Diverter Valve (Includes REF. NO. 13)	1	All Models
13	21340	Diverter Valve Solenoid	1	All Models
14	216029	Adapter (#10 ORB M to #6 ORB F)	2	All Models
15	206014	Adapter, 90° (#4 ORFS M to #6 ORB M)	4	All Models
16	216030	Restrictor (#4 ORFS M to #4 ORFS F)	2	All Models
17	216031	1/4" Hose Assembly (# 4 ORFS F to #4 ORFS F)	2	All Models
18	210074	Tilt Cylinder Weldment	1	All Models
19	216027	Adapter, 90° (#8 ORFS M to #12 ORB M)	1	All Models
20	216033	1/2" Hose Assembly (# 8 ORFS F to #10 ORB M)	2	All Models
21	216026	Adapter, 90° (#8 ORFS M to #10 ORB M)	1	All Models
22	*21220	Optional Wiring Harness	1	All Models
23	*21253	Optional Wiring Harness (Battery Connection)	1	All Models

\* For PN and full description, refer to *Accessories*.

## **WARNING**

This product can expose you to chemicals known to the State of California to cause cancer and birth defects or other reproductive harm. For more information go to [www.P65Warnings.ca.gov/product](http://www.P65Warnings.ca.gov/product).

### Wiring Harness Options

Danuser takes care to ensure the accuracy of the information contained in this manual. We assume no liability for errors contained herein. It is the responsibility of the installer to ensure that all of the products are correct before installation. Proper assembly always requires that the installer use all instructions and safety procedures. We assume no liability for any errors made in product selection or installation.

Optional wiring harness allows for tilt function from the vehicle joystick controls. It replaces the standard harness 12-volt auxiliary power port plug and control switch on the T7 and T8-RR.

- PN 21220-1 - 8-Pin used on ASV, Caterpillar, Komatsu, and Terex
- PN 21220-2 - 14-Pin used on Bobcat (prior to 1999), Case, Kubota, New Holland, Takeuchi, and Volvo
- PN 21220-3 - 14-Pin Deere used on John Deere
- PN 21220-4 - 14-Pin Caterpillar used on Caterpillar
- PN 21220-5 - 14-Pin used on Bobcat (1999 and current) and Gehl
- \* PN 21220-U1 - 8-Pin universal wiring harness. Contacts are crimped on wire but not installed in connector.
- \* PN 21220-U2 - 14-Pin universal wiring harness. Contacts are crimped on wire but not installed in connector.

\* Requires connector contacts be installed in a switchable +12-volt pin location and ground pin location. Mapping of skid-steer connector pins required.

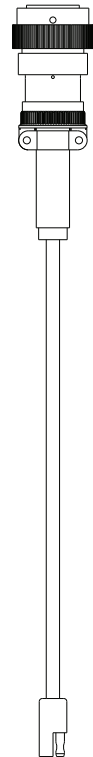

### Wiring Harness (Battery Connection)

PN 21253 - Connects to battery terminals for alternative power connection for Hornet models with tilt.

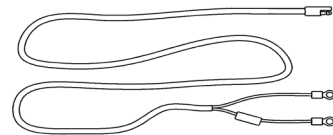

### T-post Adapter

PN 21149 - Must be added for driving T-posts. Can only be used with a flat bottom driving tool.

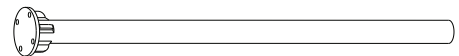

### T-post Adapter Domed Driving Tool Kit

PN 220011 - Must be added to PN 21149 for driving T-posts with a domed driving tool.

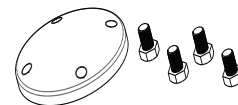

(continued)

## **WARNING**

This product can expose you to chemicals known to the State of California to cause cancer and birth defects or other reproductive harm. For more information go to [www.P65Warnings.ca.gov/product](http://www.P65Warnings.ca.gov/product).

### **Additional Weight Kit - Non-Tilt Hornets**

PN 200076 - Add up to 14 weight plates for reduced vibration and more efficient driving. 1 weight = 44 lb., 14 weights = 616 lb. Increases driving speed up to 50% faster than base unit.

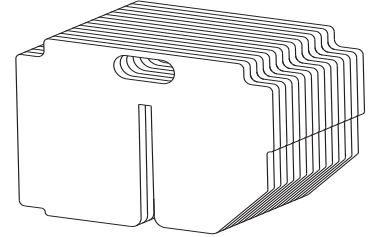

### **Additional Weight Kit - Tilt Hornets**

PN 214201 - Add up to 11 weight plates for reduced vibration and more efficient driving. 1 weight = 44 lb., 11 weights = 484 lb. Tilt intermediate weldment and additional tilt components (included with Hornet Driver) = 132 lb. Increases driving speed up to 50% faster than base unit.

### **T7 Skid-Steer Tilt Kit**

PN 214200 - Tilt left or right up to 20°. May be added to T7 Hornet only. Includes diverter switch and plug adapter that connects to a 12-volt auxiliary power outlet inside the cab.

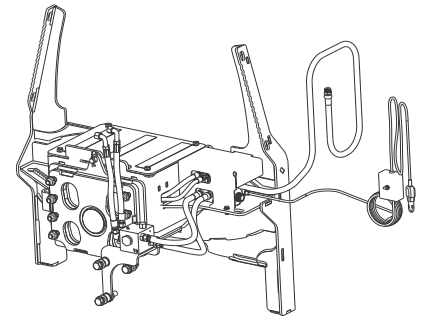

### **T8-RR Skid-Steer Tilt Kit**

PN 214205 - Tilt left or right up to 20°. May be added to T8-RR Hornet only. Includes diverter switch and plug adapter that connects to a 12-volt auxiliary power outlet inside the cab.

### **T7 Backhoe & Excavator Tilt Kit**

PN 214202 - Tilt left or right up to 20°. May be added to T7 Hornet only. Includes diverter switch and plug adapter that connects to a 12-volt auxiliary power outlet inside the cab.

### **T8-RR Backhoe & Excavator Tilt Kit**

PN 214207 - Tilt left or right up to 20°. May be added to T8-RR Hornet only. Includes diverter switch and plug adapter that connects to a 12-volt auxiliary power outlet inside the cab.

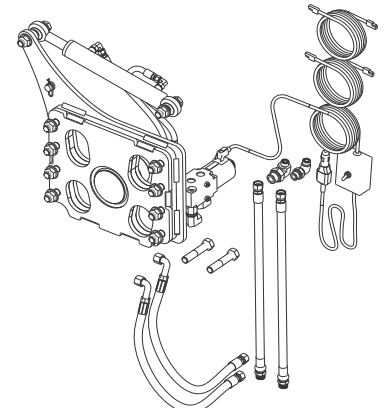

(continued)

## **WARNING**

This product can expose you to chemicals known to the State of California to cause cancer and birth defects or other reproductive harm. For more information go to [www.P65Warnings.ca.gov/product](http://www.P65Warnings.ca.gov/product).

### **T7 Skid-Steer Grapple Kit - Non-Tilt Hornets**

PN 210040 - Grapple for one-person operation, for skid-steer Hornet T7 models without tilt only.

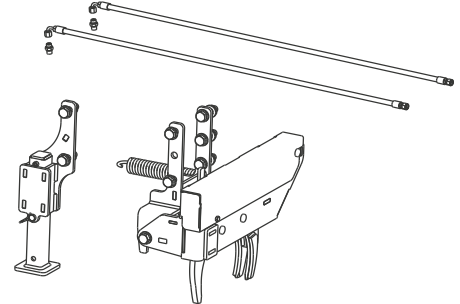

### **T7 Skid-Steer Grapple Kit - Tilt Hornets**

PN 214203 - Grapple for one-person operation, for skid-steer Hornet T7 models with tilt only.

### **T8-RR Skid-Steer Grapple Kit - Non-Tilt Hornets**

PN 210041 - Grapple for one-person operation, for skid-steer Hornet T8-RR models without tilt only.

### **T8-RR Skid-Steer Grapple Kit - Tilt Hornets**

PN 214208 - Grapple for one-person operation, for skid-steer Hornet T8-RR models with tilt only.

### **T7 Backhoe & Excavator Grapple Kit**

PN 214204 - Grapple for one-person operation, for backhoe & excavator Hornet T7 models only.

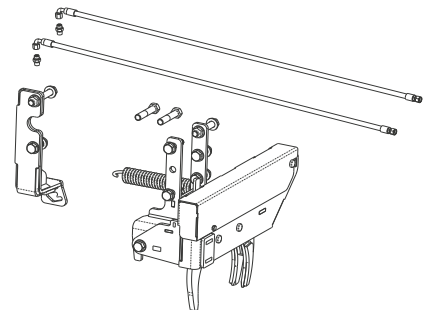

### **T8-RR Backhoe & Excavator Grapple Kit**

PN 214209 - Grapple for one-person operation, for backhoe & excavator Hornet T8-RR models only.

This page is intentionally blank.

# Warranty

# DANUSER

Model # \_\_\_\_\_

Serial # \_\_\_\_\_

## LIMITED WARRANTY

Danuser Machine Company, LLC (“Danuser”) warrants its products, under normal use and maintenance, to be free from defects in material and workmanship for period(s) specified below from the purchase date from an authorized Danuser Dealer. Start of the warranty period is determined by purchase date given on your returned WARRANTY REGISTRATION FORM. Proof of purchase may be required. This Limited Warranty is extended only to the original purchaser of Danuser products.

Hornet - 1 Year

Wear Items Not Covered Under Warranty - Hydraulic Hoses and Seals, Concrete Breaker Tool, and Rock Spike

1. During the applicable warranty period, Danuser, at its option, will repair or replace any part determined by Danuser to be defective. Such repair or replacement shall take place at Danuser’s factory or a location designated by Danuser. Under no circumstances shall Danuser be obligated for the cost of any repair or replacement by anyone other than Danuser without its express written consent.
2. Parts may not be returned without written authorization from Danuser.
3. Some purchased components, including but not limited to power cells and hydraulic components, are subject to the inspection and warranty of the respective manufacturer. Thus, delays in a warranty determination can be expected while Danuser awaits their decision.
4. This warranty is void if any attempt is made to make field repairs to power cells and hydraulic components. To qualify for warranty inspection, the “failed” part(s) must be returned in its original “failed” condition.
5. To make a claim under this warranty, first contact your authorized Danuser Dealer. The Danuser Dealer shall complete the Warranty Claim Form and obtain written authorization from Danuser to return parts. All warranty claims must include detailed information regarding make and model of vehicle on which the Danuser product was mounted, hours of use, description of events that led up to the failure, and any other information helpful in reviewing the warranty claim. All warranty returns must be prepaid. Shipments arriving at our factory on a freight collect basis will be refused by our receiving department. The freight charge will be credited if the parts are determined by Danuser to be defective, and the associated freight costs in returning those parts will be prepaid by Danuser. NOTE: Power cells and hydraulic components must arrive with all ports sealed from dirt and moisture. If a power cell or hydraulic component arrives with open ports, the warranty is void and no inspection will be made.
6. Products or parts thereof, which, as determined by Danuser’s examination, show wear from normal use, have been improperly operated, damaged by accident or negligence, field repaired, altered or modified are not considered defective in material and workmanship and are not covered by this warranty. This warranty does not apply to parts subject to normal wear (“Wear Items”) or to damage caused by the failure to perform recommended maintenance or to replace worn parts. This warranty shall not obligate Danuser to bear any cost of labor for field repair, replacement, testing, or adjustment nor for damage caused by accident, abuse, misuse, or environmental elements.
7. Any parts or labor required to repair or replace parts not covered under this warranty will be charged to the customer. Parts repaired or replaced by Danuser are then covered by this warranty only for the remainder of the original warranty as if such parts were original parts.
8. Danuser reserves the right to change its specifications and designs at any time.

This warranty is exclusive and in lieu of all other express warranties, if any, including the implied warranties of merchantability and fitness for a particular purpose. It shall not extend beyond the duration of the expressed warranty provided herein and the remedy for violations of any implied warranty shall be limited to repair or replacement of the defective part pursuant to the terms contained herein. No employee, dealer, salesman, or representative is authorized to change this warranty in any way or grant any other warranty. Danuser shall not be liable for any consequential, incidental, or punitive damages, losses, or expenses, including those resulting from or caused by any defects.

**Danuser Machine Company, LLC**  
500 E. 3rd St.  
P.O. Box 368  
Fulton, MO 65251

**Tel:** (573) 642-2246  
**E-mail:** sales@danuser.com  
**Website:** www.danuser.com

**PD 5003B**