

# PYTHON<sup>®</sup> WIRE WINDER

---

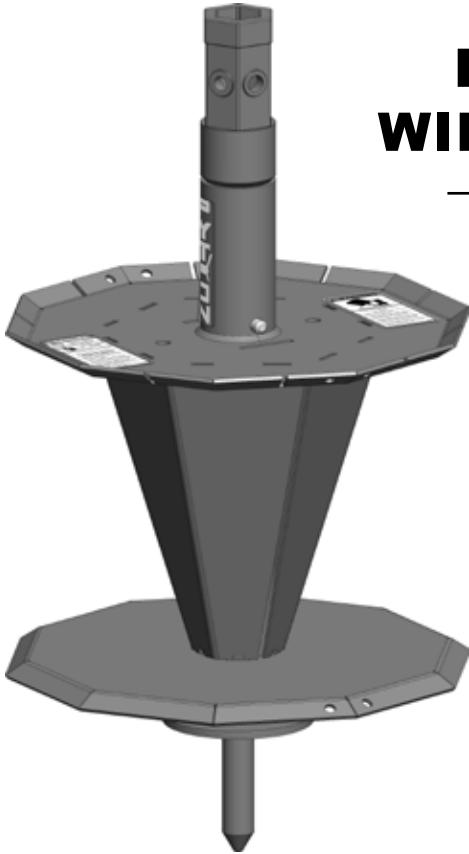

**⚠** Read this entire manual. This safety alert symbol is used throughout this manual to call your attention to messages involving your personal safety and the safety of others. Failure to follow these instructions can result in injury or death.

## **⚠ WARNING**

*Si no entiende ingles, se prefiere que busque a alguien que interprete las instrucciones para usted.*

Owner: \_\_\_\_\_

Date Purchased: \_\_\_\_\_

Manual #: 9MPYTHONWW2460752

## **Operator's Manual**

Danuser Machine Company, LLC  
500 E. 3rd St.  
P.O. Box 368  
Fulton, MO 65251  
Tel: (573) 642-2246  
E-mail: [sales@danuser.com](mailto:sales@danuser.com)  
Website: [www.danuser.com](http://www.danuser.com)



Dear Owner/Operator,

Thank you for purchasing this Danuser Python Wire Winder. We appreciate your business.

The Python Wire Winder is designed to meet the needs of farmers, ranchers, and fencing professionals. The Python Wire Winder connects onto a hydraulic auger drive unit and can wind up to 6 miles of smooth or 3/4 mile of barbed wire into convenient rolls.

Your safety as an operator of our product is very important to us. Therefore, *before* you assemble, install, operate, maintain, remove, or move your Danuser Python Wire Winder, read and understand this manual thoroughly. If there is anything you do not understand, immediately contact your dealer, or contact our factory direct.

Tel: (573) 642-2246

E-mail: [sales@danuser.com](mailto:sales@danuser.com)

Your satisfaction in the performance and longevity of our product is also very important to us and can be prolonged by proper assembly, installation, operation, and maintenance as instructed in this manual.

Thank you again for your business and for your trust in our product. Please feel free to contact us at any time for further assistance.

Sincerely,

Danuser Machine Company, LLC  
500 E. 3rd St.  
P.O. Box 368  
Fulton, MO 65251

Tel: (573) 642-2246

E-mail: [sales@danuser.com](mailto:sales@danuser.com) Website: [www.danuser.com](http://www.danuser.com)

Danuser provides this manual "as is" without warranty of any kind, either expressed or implied. Danuser assumes no responsibility for errors or omissions. Danuser assumes no liability for damages resulting from the use of the information contained herein. Danuser reserves the right to revise and improve its products as it sees fit. This manual describes the state of this product at the time of its publication and may not reflect the product in the future.

Danuser is a registered trademark.

# Foreword





Please read this manual thoroughly!

**Before** you assemble, install, operate, maintain, remove, or move your Danuser Python Wire Winder, read this manual thoroughly. If there is anything you do not understand, immediately contact your dealer, or call our factory direct at (573) 642-2246. Powered equipment can be dangerous if not assembled, installed, operated, maintained, removed, or moved properly.

# Symbols



This SAFETY ALERT symbol identifies important safety messages. Carefully read each safety message that follows. Failure to understand and obey a safety message, or recognize a safety hazard, could result in injury or death to you or others around you. The operator is ultimately responsible for the safety of himself, as well as others, in the operating area of the wire winder.

<i>Symbol</i>	<i>Meaning</i>
	Indicates an imminently hazardous situation which, if not avoided, <b>will</b> result in death or serious injury.
	Indicates a potentially hazardous situation which, if not avoided, <b>could</b> result in death or serious injury, including hazards that are exposed when guards are removed.
	Indicates a potentially hazardous situation which, if not avoided, <b>may</b> result in minor or moderate injury. It may also be used to alert against unsafe practices.
	This is important information for proper use of this equipment. Failure to comply may lead to premature equipment failure.

# Table of Contents

	Page
Letter to Owner/Operator . . . . .	2
Foreword . . . . .	3
Symbols . . . . .	3
Safety . . . . .	4
Decals & Safety Signs . . . . .	8
Specifications . . . . .	9
Assembly & Installation . . . . .	10
Operation . . . . .	10
Removal & Storage . . . . .	14
Troubleshooting . . . . .	15
Maintenance . . . . .	16
Torque Values Chart . . . . .	17
Parts . . . . .	18
Accessories . . . . .	19
Python Wire Unroller . . . . .	19
Warranty . . . . .	PD 6006

### WARNING

Working with unfamiliar equipment can lead to careless injuries. Read and understand this manual and the manual for your vehicle before assembling, installing, operating, maintaining, removing, or moving this wire winder. If there is anything in this manual you do not understand, contact your dealer or Danuser. The safe use of this equipment is strictly up to you, the operator. If this wire winder is used, loaned, or rented by any other person, it is the owner's responsibility to make certain that the operator prior to operating:

- Reads and understands the Operator's Manuals
- Is instructed in safe and proper use

There is an entanglement risk if you replace the retaining bolt and/or spool retention pin with one longer than specified by Danuser. This improper replacement occurs most often on equipment that is loaned or rented to someone who has not read the Operator's Manual and is not familiar with the wire winder.

- This wire winder is designed to be used in conjunction with a hydraulic auger drive unit mounted to the front of the vehicle. The wire winder must be positioned such that all winding operations, including the wire path, can be easily seen.
- Do not use the wire winder on a power take-off (PTO) driven post hole digger.
- It is the responsibility of the operator to see that no one is within twenty-five feet (25') of the wire winder or wire path before and during wire winder rotation. Do not operate the wire winder with another person near or in contact with any part of the drive unit or wire winder. Serious personal injury or death may result if any attempt is made to assist winding operation by hand.
- All operators of this attachment must read and understand this entire manual, paying particular attention to safety messages and operation instructions, prior to assembling, installing, operating, maintaining, removing, or moving the wire winder.
- Please remember it is also important that you read, understand, and follow the safety signs on the attachment. Clean or replace all safety signs if they cannot be clearly read and understood. They are there for your safety as well as the safety of others. Danuser will furnish new wire winder safety signs upon request at no charge.
- All things with moving parts are potentially hazardous. There is no substitute for a cautious, safe-minded operator who recognizes potential hazards and follows reasonable safety practices.

# **Safety**

(continued)

- Personal protection equipment including safety glasses, hearing protection, safety shoes, and gloves are recommended during assembly, installation, operation, maintenance, removal, or movement of the wire winder.
- When the use of hand tools is required to perform any part of assembly, installation, maintenance, removal, or movement of the wire winder, be sure the tools used are designed and recommended by the tool manufacturer for that specific task.
- Always use two people to handle heavy, unwieldy components during assembly, installation, maintenance, removal, or movement of the wire winder.
- Never place any part of your body where it would be in danger if movement should occur during assembly, installation, operation, maintenance, removal, or movement of the wire winder.
- Check clearances between vehicle and wire winder, as well as operator and wire winder, across the full range of loader arms' operating heights.
- Only properly trained people should operate this equipment. Do not allow anyone who has not read this entire manual and understood the safety rules, safety signs, and operation instructions to use this wire winder.
- Never allow children to operate or be around this wire winder.
- Do not allow riders on the equipment at any time. There is no safe place for any riders.
- Never use alcoholic beverages or drugs which can hinder alertness or coordination while operating this equipment. Consult your doctor about operating this equipment while taking prescription or over-the-counter medications.
- Safe operation of equipment requires the operator's full attention. Avoid distractions such as radio headphones, cell phones, etc. while operating.
- Before beginning operation, clear the work area of objects which might be picked up and thrown by or entangled in the wire and/or wire winder.
- Before you operate the attachment, check over all pins, bolts, and connections to be sure all are securely in place. Replace any damaged or worn parts immediately.

# Safety

(continued)

- Never replace the retaining bolt and/or the spool retention pin with anything other than one that meets the original equipment manufacturer's standards and requirements. A longer, or protruding, fastener is more likely to grab clothing or gloves, which can result in serious injury or death.
- Keep all helpers and bystanders twenty-five feet (25') away from the operating attachment and the wire path.
- Keep hands, feet, hair, jewelry, and clothing away from all moving and/or rotating parts.
- Never place yourself between the vehicle and the attachment
- Never position the wire winder by hand or with any tool when the vehicle is running.
- Never manually guide wire by hand or with tool.
- A heavy load can cause instability of the vehicle. Use extreme care during travel. Slow down on turns and watch out for bumps. Use all safety devices, including a seat belt, as recommended in the vehicle operator's manual.
- Do not operate the wire winder on steep hillsides. When winding wire on uneven or hilly terrain, position the vehicle with the hydraulic auger drive unit uphill. With the hydraulic auger drive unit downhill, the vehicle could tip when winding wire. Consult your vehicle operator's manual for maximum incline allowable.
- Always shut off the vehicle engine, remove the key, lower vehicle arms, and relieve all hydraulic pressure before dismounting the vehicle. Never leave equipment unattended with the vehicle running.
- Never attempt adjustments, service, or repairs while the attachment is in operation.
- Never work under equipment supported by hydraulics. Even with the vehicle shut off, the attachment can suddenly drop if controls are actuated or if hydraulic lines burst.
- Store the wire winder on a flat, level surface in an area where children do not play. Securely block and support the wire winder.
- Do not modify the wire winder. Modifications may weaken the integrity of the wire winder and may impair the safety, function, life, and performance of the wire winder.
- When maintaining the wire winder, use only parts that meet original equipment manufacturer's standards and requirements.

## **Safety**

(continued)

- Always use care when operating the wire winder. Most accidents occur because of neglect or carelessness.

Safety is a primary concern in the design, manufacture, sale, and use of the wire winder. Danuser confirms to you, our customer, our concern for safety.

### **DANGER**

**Improper operation of this wire winder can cause serious personal injury or death. Operation of this wire winder should only be done by a competent adult acting in compliance with the Operator's Manual. Since winding operations are beyond our control, we disclaim all liability for any damages, injuries, or death which may result.**

### **WARNING**

**This product can expose you to chemicals known to the State of California to cause cancer and birth defects or other reproductive harm. For more information go to [www.P65Warnings.ca.gov/product](http://www.P65Warnings.ca.gov/product).**

## Decals & Safety Signs

### **⚠ WARNING**

Clean or replace all safety signs if they cannot be clearly read and understood.

The Python Winder comes equipped with all safety signs in place. Their locations are shown in this section. Read and follow their instructions and ensure their care:

- Keep safety signs clean and legible at all times.
- Replace safety signs that are missing, illegible, or damaged.

To install new safety signs, follow these steps:

1. Clean the area where the safety sign is to be placed.
2. Spray a little soapy water on the surface where the safety sign is to be placed.
3. Peel the backing from the safety sign and apply it in the position shown.
4. Firmly press the safety sign and squeeze out the air bubbles with a straight edge (e.g., a credit card).

**P  
Y  
T  
H  
O  
N**<sup>®</sup>

**PART NO. CA65**

Location: center column



**PART NO. 180601**

Location: center column

**PART NO. DANUSER111**

Location: center column

**D  
A  
N  
U  
S  
E  
R**<sup>®</sup>

**PART NO. DIG50**

Location: upper spool assembly, top



**PART NO. DIG51**

Location: upper spool assembly, top



# Specifications

Operator's Manual  
Direction Terminology

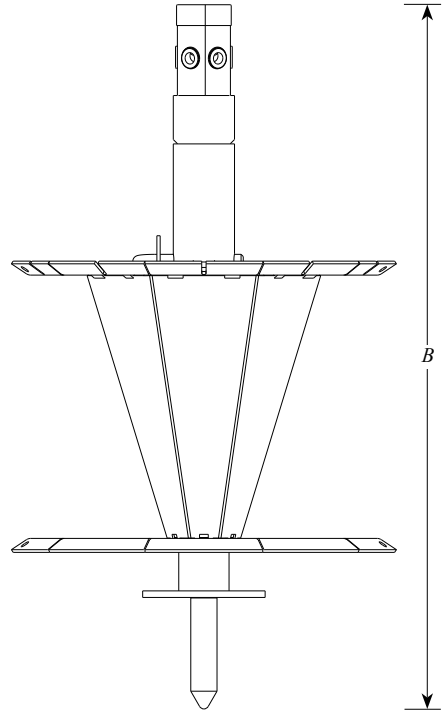
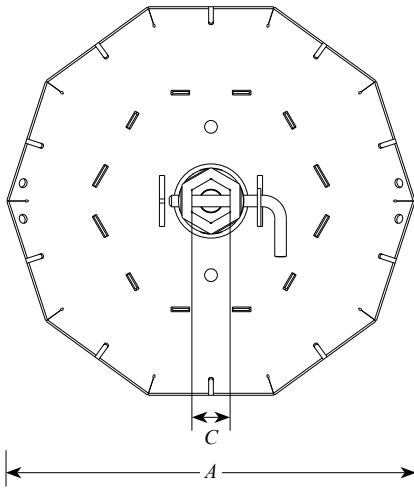
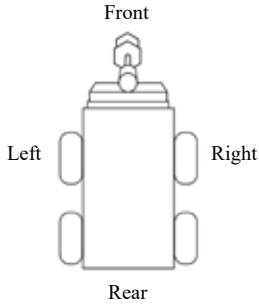

Python Wire Winder	
Overall Width (A)	22"
Overall Height (B)	40.26"
Collar Size (C)	2" Hex
Weight	98 lb.
Wire Capacity	Up to 3/4 mile barbed Up to 6 miles smooth

## Assembly & Installation

### WARNING

Personal protection equipment including safety glasses, hearing protection, safety shoes, and gloves are recommended during assembly, installation, operation, maintenance, removal, or movement of the wire winder.

### CAUTION

Always use two people to handle heavy, unwieldy components during assembly, installation, maintenance, removal, or movement of the wire winder.

## Operation

### DANGER

It is the responsibility of the operator to see that no one is within twenty-five feet (25') of the wire winder or wire path before and during wire winder rotation. Do not operate the wire winder with another person near or in contact with any part of the drive unit or wire winder. Serious personal injury or death may result if any attempt is made to assist winding operation by hand.

## Prepare the Vehicle

Read and understand the manual for your vehicle before installing or using the Python Wire Winder. This wire winder is designed to be used in conjunction with a hydraulic auger drive unit mounted to the front of the vehicle. The wire winder must be positioned such that all winding operations, including the wire path, can be easily seen.

### WARNING

**Do not use the wire winder on a power take-off (PTO) driven post hole digger.**

#### *Recommended Tools*

- 1-1/8" wrench (2)
- Box/band cutter

STEP 1: Remove pallet, banding, zip-ties, and any other packaging materials.

STEP 2: Attach wire winder onto a hydraulic auger drive unit output spindle using bolt PN 10038 (3/4"-10 x 4", Gr. 8) and nut PN 10041 included with your drive unit. NEVER use a bolt longer than 4".

### WARNING

**Before you operate the attachment, check over all pins, bolts, and connections to be sure all are securely in place. Replace any damaged or worn parts immediately.**

STEP 1: Prepare wire(s) for winding. Remove wire(s) from fenceposts, and clear wire path of any debris, obstructions, or bystanders.

#### NOTE

The wire winder is not designed to pull wire(s) directly from fenceposts. Wire(s) must be removed from posts before winding.

# Operation

(continued)

## **⚠ WARNING**

Personal protection equipment including safety glasses, hearing protection, safety shoes, and gloves are recommended during assembly, installation, operation, maintenance, removal, or movement of the wire winder.

## **⚠ WARNING**

Safe operation of equipment requires the operator's full attention. Avoid distractions such as radio headphones, cell phones, etc. while operating.

## **⚠ DANGER**

Do not allow riders on the equipment at any time. There is no safe place for any riders.

STEP 2: To ensure tight wrapping of the spool, attach a piece of log chain to the trailing end of the wire(s). This will provide resistance, keeping tension on the wire(s). If desired, multiple wires may be wound simultaneously.

STEP 3: Tie-wires may be used to secure spooled wire. Feed tie-wire ends through perimeter holes located in the upper and lower spool assemblies. Position the tie-wires into the upper spool assembly grooves. Secure tie-wire ends.



STEP 4: Attach wire(s) to wire winder using the 10 slots located at the top of the upper spool assembly.

### **NOTE**

Because smooth wire may slip out of the slot, it may be necessary to use two or more slots to secure wire(s).

STEP 5: Raise loader arms and position the hydraulic auger drive unit so the wire winder hangs freely. Apply down pressure to insert spike into the ground until the spike plate contacts the ground.

## **⚠ DANGER**

Never position the wire winder by hand or with any tool when the vehicle is running.



## Operation

(continued)

### **⚠ WARNING**

**Keep hands, feet, hair, jewelry, and clothing away from all moving and/or rotating parts.**

### **⚠ DANGER**

**Before beginning operation, clear the work area of objects which might be picked up and thrown by or entangled in the wire and/or wire winder.**

STEP 6: Activate the vehicle auxiliary hydraulics to start the wire winder rotating in the clockwise direction. Increase the speed as required as wire(s) are wound onto the wire winder.

### **⚠ DANGER**

**Keep all helpers and bystanders twenty-five feet (25') away from the wire winder or wire path before and during wire winder rotation. The wire winder must be positioned such that all winding operations, including the wire path, can be easily seen.**

#### **NOTE**

Tilting the wire winder toward and away from the direction of the wire path will allow for even spooling.

### **⚠ DANGER**

**Never manually guide wire by hand or with tool.**



# Operation

(continued)

STEP 7: Once wire is wound, remove log chain. If tie-wires are used, secure the wound wire.



STEP 8: Apply down pressure to insert wire winder spike fully into the ground, compressing the wire winder upper and lower spool assemblies and relieving pressure on retention pin.

STEP 9: Remove spool retention pin, allowing the upper spool assembly to be lifted free and the wound wire removed.

**⚠ DANGER**

**Never place yourself between the vehicle and the attachment.**



**NOTE**

Store the retention pin in one of the two holes in the wire winder upper spool assembly.

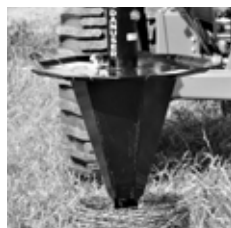

## Operation

(continued)

STEP 10: With the wound wire removed, the upper spool assembly can be reassembled with the lower spool assembly by lining up the tie-wire holes on top and bottom, then sliding the lower section into the upper until the retention pin hole is visible. Replace the retention pin and rotate to secure it in place

### DANGER

**Never replace the spool retention pin with anything other than one that meets the original equipment manufacturer's standards and requirements. A longer, or protruding, fastener is more likely to grab clothing or gloves, which can result in serious injury or death.**

## Removal & Storage

### DANGER

**Never allow anyone under the attachment at any time.**

### WARNING

**Personal protection equipment including safety glasses, hearing protection, safety shoes, and gloves are recommended during assembly, installation, operation, maintenance, removal, or movement of the wire winder.**

Before storage, the Python Wire Winder should be thoroughly cleaned, washing off all dirt and grime. Always store the wire winder in a dry, covered location.

STEP 1: If storing the attachment, lower the hydraulic auger drive unit and Python onto a flat, level surface in an area where children do not play. Follow your vehicle operator's manual for removing an attachment. Securely block and support the attachment.

#### NOTE

Take care to gently set down the wire winder. The hydraulic auger drive unit's weight can cause the wire winder spool assemblies to bend if set down improperly.

STEP 2: If storing the Python disconnected from the hydraulic auger drive unit, remove the retaining bolt and nut. Separate the wire winder from the drive unit, and lower it onto a flat, level surface in an area where children do not play.

STEP 3: Replace any damaged or missing safety signs.

# Troubleshooting

<b>Problem</b>	<b>Possible Cause</b>	<b>Solution</b>
Wire(s) not winding evenly	Python not properly tilted while winding	Refer to <i>Operation</i> .
End of wire(s) moving erratically	Log chain not in use	Attach log chain to end of wire(s).
	Winding too fast	Reduce engine RPM.
Wire(s) breaking	Obstacles or tall grass snagging wire(s) while winding	Ensure grass is cut and obstacles are cleared from wire(s) path.
Retaining bolt and nut vibrate loose	Improper torquing	Ensure retaining bolt and nut are torqued properly. See <i>Torque Values Chart</i> .
Retention pin hard to remove	Retention pin requires down pressure to remove	Refer to <i>Operation</i> .
Retention pin cannot be reinserted	Upper and lower spool assemblies not aligned	Ensure sections are aligned prior to reassembly.
Python comes out of ground during operation	Spike not pressed fully into ground	Apply greater down pressure.
	Sandy or loose ground conditions	If possible, find firmer ground nearby.

*For additional assistance, please call your dealer or contact Danuser direct:*

*Tel: (573) 642-2246*

*E-mail: [sales@danuser.com](mailto:sales@danuser.com)*

## Maintenance

### DANGER

Never work under equipment supported by hydraulics. Even with the vehicle shut off, the attachment can suddenly drop if controls are actuated or hydraulic lines burst.

### WARNING

Personal protection equipment including safety glasses, hearing protection, safety shoes, and gloves are recommended during assembly, installation, operation, maintenance, removal, or movement of the wire winder.

Proper maintenance is key to the long life of the wire winder. Careful inspection and routine maintenance help avoid costly downtime and repair. Do not use the Python Wire Winder with any damaged parts.

### DANGER









Never replace the retaining bolt and/or spool retention pin with anything other than one that meets the original equipment manufacturer's standards and requirements. A longer, or protruding, fastener is more likely to grab clothing or gloves, which can result in serious injury or death.

### WARNING

Do not modify the wire winder. Modifications may weaken the integrity of the wire winder and may impair the safety, function, life, and performance of the wire winder.

Maintenance	Interval
Inspect the attachment for any damage or worn parts. Repair or replace as necessary.	Before each use
Check for damaged or missing safety signs. Replace as necessary.	Before each use
Visually inspect all welds for cracks. Check all bolts and fasteners for tightness.	Before each use
Inspect upper and lower spool plates for damage. Inspect lower assembly for bending.	Before each use

# Torque Values Chart

Torque Values Chart																	
Bolt Size (inches)	Bolt Head Identification								Bolt Size (Metric)	Bolt Head Identification							
	 Grade 2		 Grade 5		 Grade 8		 ASTM A574			Class 5.8 		Class 8.8 		Class 10.9 		Class 12.9 	
in-tpi	Nm	ft.-lb.	Nm	ft.-lb.	Nm	ft.-lb.	Nm	ft.-lb.	mm x pitch	Nm	ft.-lb.	Nm	ft.-lb.	Nm	ft.-lb.	Nm	ft.-lb.
1/4"-20	7.4	5.6	11	8	16	12	19	14	M5 x 0.8	4	3	6	5	9	7	11	8
1/4"-28	8.5	6	13	10	18	14	22	16	M6 x 1	7	5	11	8	15	11	18	13
5/16"-18	15	11	24	17	33	25	39	29	M8 x 1.25	17	12	26	19	36	27	42	31
5/16"-24	17	13	26	19	37	27	43	32	M8 x 1	18	13	28	21	39	29	46	34
3/8"-16	27	20	42	31	59	44	69	51	M10 x 1.5	33	24	52	39	72	53	84	62
3/8"-24	31	22	47	35	67	49	79	58	M10 x 0.75	39	29	61	45	85	62	98	72
7/16"-14	43	32	67	49	95	70	110	81	M12 x 1.75	58	42	91	67	125	93	148	109
7/16"-20	49	36	75	55	105	78	123	91	M12 x 1.5	60	44	95	70	130	97	153	113
1/2"-13	66	49	105	76	145	105	168	124	M12 x 1	90	66	105	77	145	105	167	123
1/2"-20	75	55	115	85	165	120	190	140	M14 x 2	92	68	145	105	200	150	235	173
9/16"-12	95	70	150	110	210	155	235	173	M14 x 1.5	99	73	155	115	215	160	254	187
9/16"-18	105	79	165	120	235	170	262	193	M16 x 2	145	105	225	165	315	230	365	269
5/8"-11	130	97	205	150	285	210	323	238	M16 x 1.5	155	115	240	180	335	245	388	286
5/8"-18	150	110	230	170	325	240	366	270	M18 x 2.5	195	145	310	230	405	300	504	372
3/4"-10	235	170	360	265	510	375	574	423	M18 x 1.5	220	165	350	260	485	355	561	414
3/4"-16	260	190	405	295	570	420	640	472	M20 x 2.5	280	205	440	325	610	450	712	525
7/8"-9	225	165	585	430	820	605	925	682	M20 x 1.5	310	230	650	480	900	665	1052	776
7/8"-14	250	185	640	475	905	670	1020	752	M24 x 3	480	355	760	560	1050	780	1231	908
1"-8	340	250	875	645	1230	910	1386	1022	M24 x 2	525	390	830	610	1150	845	1337	986
1"-12	370	275	955	705	1350	995	1555	1147	M30 x 3.5	960	705	1510	1120	2100	1550	2447	1805
1-1/8"-7	480	355	1080	795	1750	1290	1971	1454	M30 x 2	1060	785	1680	1240	2320	1710	2706	1996
1-1/8"-12	540	395	1210	890	1960	1440	2202	1624	M36 x 3.5	1730	1270	2650	1950	3660	2700	4272	3151
1-1/4"-7	680	500	1520	1120	2460	1820	2771	2044	M36 x 2	1880	1380	2960	2190	4100	3220	5095	3758
1-1/4"-12	750	555	1680	1240	2730	2010	3068	2263	<b>KEY:</b> in-tpi = nominal thread diameter in inches-threads per inch Nm = Newton-meter ft.-lb. = foot pounds mm x pitch = nominal thread diameter in millimeters by thread pitch								
1-3/8"-6	890	655	1990	1470	3230	2380	3638	2683									
1-3/8"-12	1010	745	2270	1670	3680	2710	4143	3056									
1-1/2"-6	1180	870	2640	1950	4290	3160	4823	3557									
1-1/2"-12	1330	980	2970	2190	4820	3560	5426	4002									

Torque tolerance +0%, -15% of torque values. Unless otherwise specified, use torque values listed above.

This product can expose you to chemicals known to the State of California to cause cancer and birth defects or other reproductive harm. For more information go to [www.P65Warnings.ca.gov/product](http://www.P65Warnings.ca.gov/product).

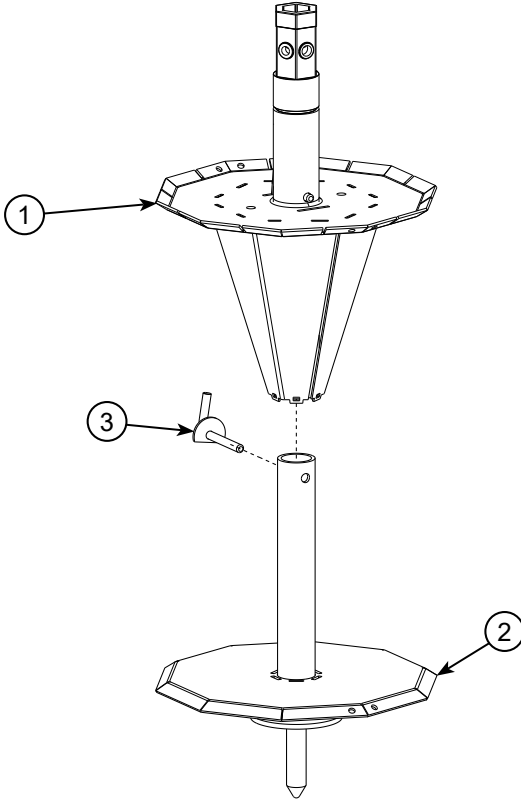

REF. NO.	PART NO.	DESCRIPTION	QTY.
1	170611	Upper Spool Assembly	1
2	170612	Lower Spool Assembly	1
3	170626	Spool Retention Pin	1

## Accessories

---

### Auger Adapter

PN 10923 - Allows Python to connect onto 2-9/16" round output spindles with 7/8" bolt hole. Not for use with power take-off (PTO) driven post hole diggers.

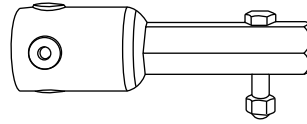

## Python Wire Unroller

---

### Python Wire Unroller

PN 180606 - The Python Wire Unroller connects onto a 2" receiver hitch and accepts pre-wound wire or bundles wound using the Python Wire Winder.

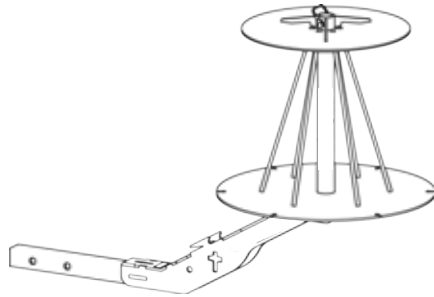

# Warranty

# DANUSER LIMITED WARRANTY

Danuser Machine Company, LLC (“Danuser”) warrants its products, under normal use and maintenance, to be free from defects in material and workmanship for period(s) specified below from the purchase date from an authorized Danuser Dealer. Start of the warranty period is determined by purchase date. Proof of purchase may be required. This Limited Warranty is extended only to the original purchaser of Danuser products.

## Python Wire Winder - 1 Year

1. During the applicable warranty period, Danuser, at its option, will repair or replace any part determined by Danuser to be defective. Such repair or replacement shall take place at Danuser’s factory, or a location designated by Danuser. Under no circumstances shall Danuser be obligated for the cost of any repair or replacement by anyone other than Danuser without its express written consent.
2. Parts may not be returned without written authorization from Danuser.
3. Some purchased components, including but not limited to hydraulic components, are subject to the inspection and warranty of the respective manufacturer. Thus, delays in a warranty determination can be expected while Danuser awaits their decision.
4. This warranty is void if any attempt is made to make field repairs to hydraulic components. To qualify for warranty inspection, the “failed” part(s) must be returned in its original “failed” condition.
5. To make a claim under this warranty, first contact your authorized Danuser Dealer. The Danuser Dealer shall complete the Warranty Claim Form and obtain written authorization from Danuser to return parts. All warranty claims must include detailed information regarding make and model of vehicle on which the Danuser product was mounted, hours of use, description of events that led up to the failure, and any other information helpful in reviewing the warranty claim. All warranty returns must be prepaid. Shipments arriving at our factory on a freight collect basis will be refused by our receiving department. The freight charge will be credited if the parts are determined by Danuser to be defective, and the associated freight costs in returning those parts will be prepaid by Danuser. **NOTE:** Hydraulic components must arrive with all ports sealed from dirt and moisture. If a hydraulic component arrives with open ports, the warranty is void and no inspection will be made.
6. Products or parts thereof which, as determined by Danuser’s examination, show wear from normal use, have been improperly operated, damaged by accident or negligence, field repaired, altered or modified are not considered defective in material and workmanship and are not covered by this warranty. This warranty does not apply to parts subject to normal wear (“Wear Items”) or to damage caused by the failure to perform recommended maintenance or to replace worn parts. This warranty shall not obligate Danuser to bear any cost of labor for field repair, replacement, testing, or adjustment nor for damage caused by accident, abuse, misuse, or environmental elements.
7. Any parts or labor required to repair or replace parts not covered under this warranty will be charged to the customer. Parts repaired or replaced by Danuser are then covered by this warranty only for the remainder of the original warranty as if such parts were original parts.
8. Danuser reserves the right to change its specifications and designs at any time.

This warranty is exclusive and in lieu of all other express warranties, if any, including the implied warranties of merchantability and fitness for a particular purpose. It shall not extend beyond the duration of the expressed warranty provided herein and the remedy for violations of any implied warranty shall be limited to repair or replacement of the defective part pursuant to the terms contained herein. No employee, dealer, salesman, or representative is authorized to change this warranty in any way or grant any other warranty. Danuser shall not be liable for any consequential, incidental, or punitive damages, losses, or expenses, including those resulting from or caused by any defects.

**Danuser Machine Company, LLC**  
500 E. 3rd St  
P.O. Box 368  
Fulton, MO 65251

**Tel:** (573) 642-2246  
**E-mail:** sales@danuser.com  
**Website:** www.danuser.com