

HAMMER

CB40

! Read this entire manual. This safety alert symbol is used throughout this manual to call your attention to messages involving your personal safety and the safety of others. Failure to follow these instructions can result in injury or death.

! WARNING

Si no entiende ingles, se prefiere que busque a alguien que interprete las instrucciones para usted.

Owner: _____

Date Purchased: _____

Model #: _____ Serial #: _____

Manual #: 9MHAMCB2460832

Operator's Manual

Danuser Machine Company, LLC
500 E. 3rd St.
P.O. Box 368
Fulton, MO 65251
Tel: (573) 642-2246
E-mail: sales@danuser.com
Website: www.danuser.com



Dear Owner/Operator,

Thank you for purchasing this Danuser Hammer CB40. We appreciate your business.

With a 500 lb. breaker weight, the Hammer CB40 is designed to break up to 9" reinforced concrete.

Your safety as an operator of our product is very important to us. Therefore, *before* you assemble, install, operate, maintain, service, remove, or move your Danuser Hammer CB40, read and understand this manual thoroughly. If there is anything you do not understand, immediately contact your dealer, or contact our factory direct.

Tel: (573) 642-2246
E-mail: sales@danuser.com

Your satisfaction in the performance and longevity of our product is also very important to us and can be prolonged by proper assembly, installation, operation, and maintenance as instructed in this manual.

Thank you again for your business and for your trust in our product. Please feel free to contact us at any time for further assistance.

Sincerely,

Danuser Machine Company, LLC
500 E. 3rd St.
P.O. Box 368
Fulton, MO 65251

Tel: (573) 642-2246
E-mail: sales@danuser.com Website: www.danuser.com

Danuser provides this manual "as is" without warranty of any kind, either expressed or implied. Danuser assumes no responsibility for errors or omissions. Danuser assumes no liability for damages resulting from the use of the information contained herein. Danuser reserves the right to revise and improve its products as it sees fit. This manual describes the state of this product at the time of its publication and may not reflect the product in the future.

Danuser is a registered trademark.

Foreword

Please read this manual thoroughly!

Before you assemble, install, operate, maintain, service, remove, or move your Danuser Hammer, read this manual thoroughly. If there is anything you do not understand, immediately contact your dealer, or call our factory direct at (573) 642-2246. Powered equipment can be dangerous if not assembled, installed, operated, maintained, serviced, removed, or moved properly.

Warranty Registration

To activate your warranty coverage and to provide you with efficient customer service, please fill out your WARRANTY REGISTRATION FORM. This form is included in your unit's paperwork package. If you did not complete a WARRANTY REGISTRATION FORM or did not receive one, please call Danuser. Or, register online at www.danuser.com. Your satisfaction with our product and your safety as a user of our product are both very important to us.

Symbols

 This SAFETY ALERT symbol identifies important safety messages. Carefully read each safety message that follows. Failure to understand and obey a safety message, or recognize a safety hazard, could result in injury or death to you or others around you. The operator is ultimately responsible for the safety of himself, as well as others, in the operating area of the Hammer.





<i>Symbol</i>	<i>Meaning</i>
	Indicates an imminently hazardous situation which, if not avoided, will result in death or serious injury.
	Indicates a potentially hazardous situation which, if not avoided, could result in death or serious injury, including hazards that are exposed when guards are removed.
	Indicates a potentially hazardous situation which, if not avoided, may result in minor or moderate injury. It may also be used to alert against unsafe practices.
	This is important information for proper use of this equipment. Failure to comply may lead to premature equipment failure.

Table of Contents

	Page
Letter to Owner/Operator	2
Foreword	3
Symbols	3
Safety	4
Decals & Safety Signs	7
Specifications	9
Hydraulic Requirements	10
Assembly & Installation	11
Operation	16
Removal & Storage	18
Troubleshooting	19
Maintenance & Lubrication	20
Service	22
Torque Values Chart	23
Parts	24
Warranty	PD 5034B

WARNING

Working with unfamiliar equipment can lead to careless injuries. Read and understand this manual and the manual for your vehicle before assembling, installing, operating, maintaining, servicing, removing, or moving this Danuser Hammer. If there is anything in this manual you do not understand, contact your dealer or Danuser. The safe use of this attachment is strictly up to you, the operator. If this attachment is used, loaned, or rented by any other person, it is the owner's responsibility to make certain that the operator prior to operating:

- Reads and understands the Operator's Manual
- Is instructed in safe and proper use
- The Hammer is designed to be operated from the vehicle operator station. Keep bystanders away from the work area. Do not operate with another person in contact with any part of the Hammer.
- All operators of this attachment must read and understand this entire manual, paying particular attention to safety messages and operation instructions, prior to assembling, installing, operating, maintaining, servicing, removing, or moving the Hammer.
- Please remember it is also important that you read, understand, and follow safety signs on the attachment. Clean or replace all safety signs if they cannot be clearly read and understood. They are there for your safety as well as the safety of others. Danuser will furnish new safety signs upon request at no charge.
- All things with moving parts are potentially hazardous. There is no substitute for a cautious, safe-minded operator who recognizes potential hazards and follows reasonable safety practices.
- Personal protection equipment including hard hat, safety glasses, safety shoes, gloves, and hearing protection are recommended during assembly, installation, operation, maintenance, service, removal, or movement of the attachment.
- Exposure to silica dust and other dust hazards can cause serious or fatal respiratory disease. Use appropriate respiratory protection.
- When the use of hand tools is required to perform any part of assembly, installation, operation, maintenance, or service of the attachment, be sure the tools used are designed and recommended by the tool manufacturer for that specific task.
- Never check pressurized system for leaks with your bare hand. Wear proper hand and eye protection and use wood or cardboard when searching for suspected leaks. Oil escaping from pinhole leaks under pressure can penetrate skin and create a serious medical emergency. If any fluid is injected into the skin, gangrene, blood poisoning, even death may result. Obtain medical attention immediately.
- Always use two people to handle heavy, unwieldy components during assembly, installation, maintenance, service, removal, or movement of the attachment.
- Never place any part of your body where it would be in danger if movement should occur during assembly, installation, operation, maintenance, service, removal, or movement of the Hammer.
- Only properly trained people should operate this equipment. Do not allow anyone who has not read this entire manual and understands the safety rules, safety signs, and operation instructions to use this attachment.
- Never allow children to operate or be around the Hammer.
- Do not allow riders on the equipment at any time. There is no safe place for any riders.

Safety

(continued)

- Never use alcoholic beverages or drugs which can hinder alertness or coordination while operating this equipment. Consult your doctor about operating this equipment while taking prescription or over-the-counter medications.
- Safe operation of equipment requires the operator's full attention. Avoid distractions such as radio headphones, cell phones, etc. while operating.
- Contact with underground gas lines or electrical cables may result in serious injury or death from explosion or electrical shock. Before operating, call 811 or the local number to locate underground utilities.
- Do not operate near underground utility lines.
- Stay away from power lines when transporting, raising, or operating the attachment. Electrocutation can occur without direct contact.
- The Hammer must be securely latched to the vehicle. Ensure both locking handles are in the locked position with pins fully seated. An improperly latched Hammer can fall without warning.
- Before you operate the attachment, check over pins and connections to be sure all are securely in place.
- Make sure all guards are in place and secure before operating equipment.
- Keep hands, feet, hair, jewelry, and clothing away from all moving and/or rotating parts.
- Never place yourself between the vehicle and the attachment.
- Never allow anyone under the attachment at any time.
- Keep clear of the Hammer while in operation.
- Do not exceed the vehicle's rated operating load. Use sufficient counterweights. Move the vehicle slowly when the attachment is raised.
- Carry the load low. A heavy load can cause instability of the vehicle. Use extreme care during travel. Slow down on turns and watch out for bumps. Use all safety devices, including a seat belt, as recommended in the vehicle operator's manual.
- Do not operate the Hammer on steep hillsides. When operating the Hammer on uneven or hilly terrain, position the vehicle with the attachment uphill. With the attachment downhill, the vehicle could tip when attempting to raise the Hammer. Consult your vehicle operator's manual for maximum incline allowable.
- Always shut off the vehicle engine, remove the key, lower vehicle arms, and relieve all hydraulic pressure before dismounting the vehicle. Never leave equipment unattended with the vehicle running.
- Never attempt adjustments, service, or repairs while the equipment is in operation.
- Never work under equipment supported by hydraulics. Even with the vehicle shut off equipment can suddenly drop if controls are actuated or if hydraulic lines burst.
- Before servicing or adjusting attachment, relieve all stored energy.
- Before connecting or disconnecting hydraulic lines or fittings, be sure to relieve all pressure by cycling all hydraulic controls after shutdown. Remember hydraulic systems are under pressure whenever the engine is running and may hold pressure after shutdown.
- Store the attachment on a flat, level surface in an area where children do not play. Securely block and support the attachment.

Safety

(continued)

- Do not modify the attachment. Modifications may weaken the integrity of the attachment and may impair the safety, function, life, and performance of the Hammer.
- When making repairs or servicing the Hammer, use only parts that meet original equipment manufacturer's standards and requirements.
- Always use care when operating the Hammer. Most accidents occur because of neglect or carelessness.

Safety is a primary concern in the design, manufacture, sale, and use of Hammers. Danuser confirms to you, our customer, our concern for safety.

DANGER

Improper operation of this Hammer can cause serious personal injury or death. Operation of this attachment should only be done by a competent adult acting in compliance with the Operator's Manual. Since Hammer operations are beyond our control, we disclaim all liability for any damages, injuries, or death which may result.

CALIFORNIA WARNING

This product can expose you to chemicals including lead, which are known to the State of California to cause cancer and birth defects or other reproductive harm. For more information go to www.P65Warnings.ca.gov.

Decals & Safety Signs

The Hammer comes equipped with all safety signs in place. Their locations are shown in this section. Read and follow their instructions and ensure their care:

- Keep safety signs clean and legible at all times.
- Replace safety signs that are missing, illegible, or damaged.
- Ensure replacement parts installed during repair have safety signs attached.

To install new safety signs, follow these steps:

1. Clean the area where the safety sign is to be placed.
2. Spray a little soapy water on the surface where the safety sign is to be placed.
3. Peel the backing from the safety sign and apply it in the position shown.
4. Firmly press the safety sign and squeeze out the air bubbles with a straight edge (e.g., a credit card).

PART NO. DIG13

Location: Unit, right side



PART NO. DIG21

Location: Unit, right side



PART NO. DANUSER109

Location: Unit, front



PART NO. DIG28

Location: Unit, right side



PART NO. 21268

Location: Unit, front

PART NO. 21161

Location: Unit, front

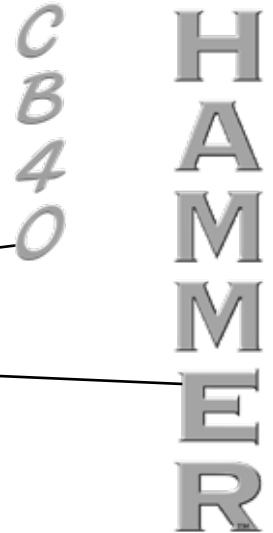

PART NO. DIG29

Location: Unit, right side



PART NO. DIG30

Location: Unit, right side

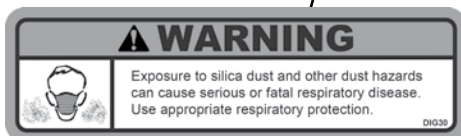

PART NO. CA65

Location: Unit, right side

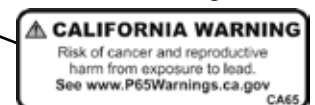

PART NO. DIG35

Location: Quick attach plate, front

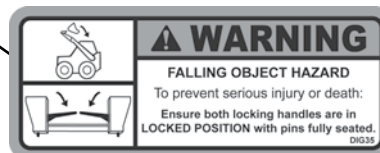

Clean or replace all safety signs if they cannot be clearly read and understood.

Decals & Safety Signs

(continued)

PART NO. DIG22
Location: Unit, top



Model No. & Serial No.
Location: Unit, rear



PART NO. 20658
Location: Unit, rear



PART NO. 20673
Location: Unit, rear



PART NO. DIG5
Location: Unit, left side



PART NO. DIG23
Location: Unit, rear



PART NO. DIG24
Location: Unit, rear



PART NO. PHDC6
Location: Unit, inside rear

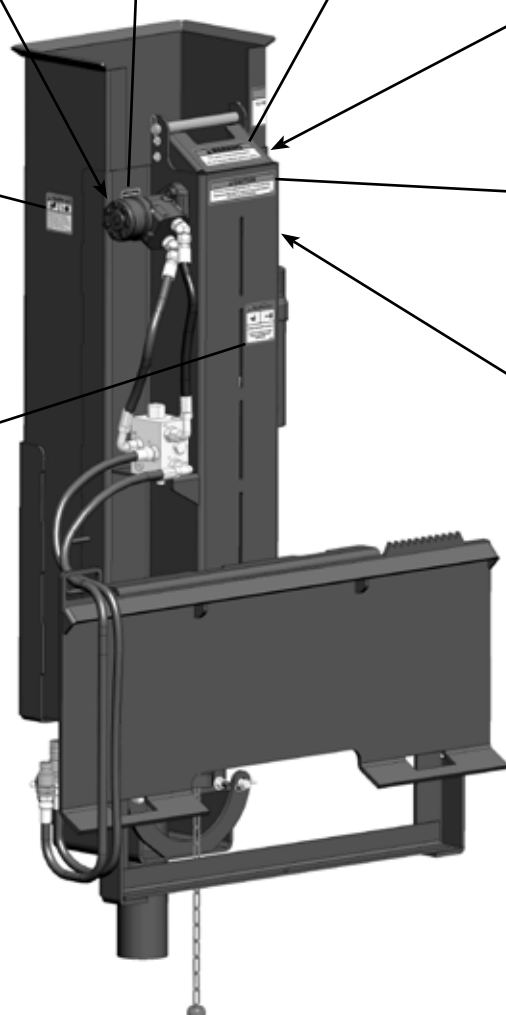

Clean or replace all safety signs if they cannot be clearly read and understood.

Specifications

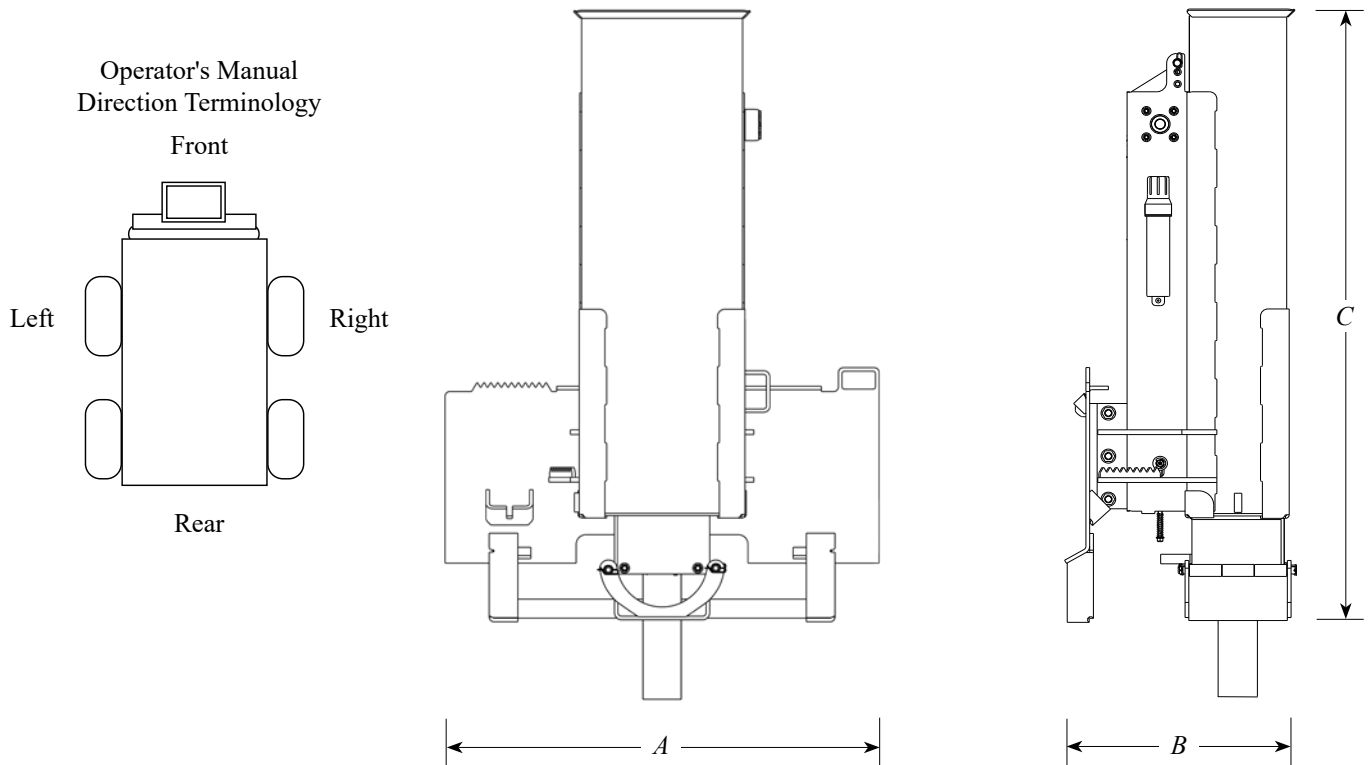

Hammer	Model CB40
Overall Width (A)	45.5"
Overall Length (B)	25"
Overall Height (C)	64"
Breaker Weight	500 lb.
Length of Stroke	40"
Max. Strokes Per Minute	35
Hydraulic Requirements	1,500-3,000 PSI Up to 30 GPM
Maximum Concrete Thickness	9"
Impact Force	82,000 lb.
Impact Energy	1,709 ft.-lb.
Hitch	Skid-Steer Quick Attach

Hydraulic Requirements

Filtration Requirements:

- A filter of, at least, 10 micron filtration is required.

NOTE

The life of the hydraulic componentry is almost entirely dependent upon cleanliness of the oil. Instructions in your vehicle operator's manual regarding filter and oil changes should be carefully followed. Even small amounts of dirt in the hydraulic oil can cause premature hydraulic componentry failure that is not covered by warranty.

Pressure and Flow Requirements:

- The Hammer is designed to operate up to 30 GPM and 1,500 – 3,000 PSI.

Hydraulic Fluid Selection Requirements:

- Premium grade petroleum based fluids will provide the best performance.
- Fluids that contain anti-wear agents, rust inhibitors, anti-foaming agents, and oxidation inhibitors are recommended.
- The viscosity of the fluid should never fall below 70 SUS (13 cST). The best viscosity range for the Hammer is 100-200 SUS (20-43 cST).

Assembly & Installation

DANGER

Never allow anyone under the attachment at any time.

WARNING

Personal protection equipment including hard hat, safety glasses, safety shoes, gloves, and hearing protection are recommended during assembly, installation, operation, maintenance, service, removal, or movement of the attachment.

WARNING

Before servicing or adjusting attachment, relieve all stored energy.

CAUTION

Always use two people to handle heavy, unwieldy components during assembly, installation, maintenance, service, removal, or movement of the attachment.

WARNING

Keep hands, feet, hair, jewelry, and clothing away from all moving and/or rotating parts.

Prepare the Vehicle

Read and understand the manual for your vehicle before assembling or installing the Hammer. The vehicle must be equipped with a skid-steer quick attach hitch and auxiliary hydraulics. The use of the Hammer may require the addition of counterweights to ensure the combined weight of the attachment and load does not exceed the rated capacity of your vehicle.

WARNING

Do not exceed the vehicle's rated operating load. If necessary, use sufficient counterweights.

STEP 1: Park the vehicle on level ground, and install the Hammer by following your vehicle operator's manual for installing an attachment.

WARNING

The Hammer must be securely latched to the vehicle. Ensure both locking handles are in the locked position with pins fully seated. An improperly latched Hammer can fall without warning.

STEP 2: Route the hydraulic hoses through the quick attach plate hose holder, and connect the hydraulic hoses to the vehicle's auxiliary hydraulics.

WARNING

Before connecting or disconnecting hydraulic lines or fittings, be sure to relieve all pressure by cycling all hydraulic controls after shutdown. Remember hydraulic systems are under pressure whenever the engine is running and may hold pressure after shutdown.

NOTE

Ensure quick couplers are clean prior to connection.

NOTE

Hose routing is the responsibility of the operator. Pinched and/or stretched hoses are not covered under the warranty.

STEP 3: Start the vehicle. Raise the loader arms until the breaker weight is completely off the ground. Activate the auxiliary hydraulics. Note the direction of the chain rotation (visible from the operator's seat). The breaker weight catch should be rotating from the top to the bottom. If the chain is not rotating at all, reverse the hydraulic hoses.

STEP 4: Check the hydraulic system for leaks.

WARNING

Never check pressurized system for leaks with your bare hand. Wear proper hand and eye protection and use wood or cardboard when searching for suspected leaks. Oil escaping from pinhole leaks under pressure can penetrate skin and create a serious medical emergency. If any fluid is injected into the skin, gangrene, blood poisoning, even death may result. Obtain medical attention immediately.

Assembly & Installation

(continued)

STEP 5: Ensure the retention pin is in place. The retention pin prevents the breaker weight from sliding out of the Hammer.

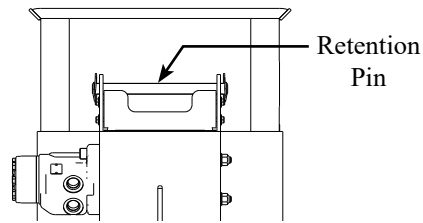

⚠ WARNING

Do not operate the Hammer without the retention pin in place. The breaker weight could slide out of the Hammer and cause serious injury or death.

STEP 6: Shut off the vehicle engine and relieve all hydraulic pressure.

STEP 7: Oil the Hammer drive chain, and grease all zerks.

Assembly & Installation

Installation of Concrete Breaker Kit PN 21278 into Hammer Post Driver

Throughout this section, REF. NO. # refers to the Reference Numbers assigned to each part in the kit. Use the Parts page to match each REF. NO. # with its corresponding part during installation.

Any Hammer post driver may be converted into a Hammer concrete breaker.

Recommended Tools

- 3/4" wrench
- Shop towels
- Hoist / vehicle capable of lifting 500 lb.
- 11/16" wrench
- Pliers
- 1/4" Allen wrench
- Lifting hook & chain
- Flathead screwdriver
- Blocking

STEP 1: Park the vehicle on level ground, and install the Hammer by following your vehicle operator's manual for installing an attachment.

⚠ WARNING

The Hammer must be securely latched to the vehicle. Ensure both locking handles are in the locked position with pins fully seated. An improperly latched Hammer can fall without warning.

STEP 2: Ensure the Hammer weight is not partially raised by making sure the weight catch is visible through the viewing slots on the back of the case.



Assembly & Installation

(continued)

STEP 3: Using pliers or flathead screwdriver, remove one (1) of the two (2) rue clips (A) on the retention pin (B) and slide pin out. Insert a hook into the lifting eye (C) located on the top of the weight. Lift the weight out of the Hammer with a hoist, forklift, or another vehicle. Set the weight on the ground.

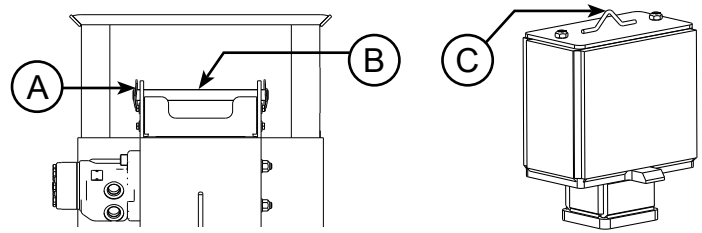

STEP 4: Using the vehicle, slowly tilt the Hammer forward into a horizontal position.



STEP 5: Slowly lower the Hammer onto a flat, level surface, or use blocking to securely support the Hammer.

⚠️ WARNING

Never work under equipment supported by hydraulics. Even with the vehicle shut off, equipment can suddenly drop if controls are actuated or hydraulic lines burst.

STEP 6: Shut off the vehicle. Engage the parking brake or securely chock vehicle to prevent movement.

⚠️ WARNING

Always shut off the vehicle engine, remove the key, lower vehicle arms, and relieve all hydraulic pressure before dismantling the vehicle. Never leave equipment unattended with the vehicle running.

STEP 7: Remove the strike plate from the bottom of the Hammer by tilting the upper edge toward the top of the Hammer, and use your hands to lift the bottom edge up to clear the bolt heads.



Assembly & Installation

(continued)

STEP 8: Using pliers or flathead screwdriver, remove one (1) of the two (2) rue clips (A) on the pin (B) and slide pin out. Remove the foot (C). Hammers equipped with a grapple will not have a foot.

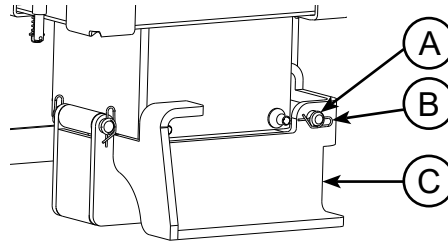

STEP 9: Using pliers or flathead screwdriver, remove one (1) of the two (2) rue clips (A) on the pin (B) and slide pin out. Remove the parking stand (C).

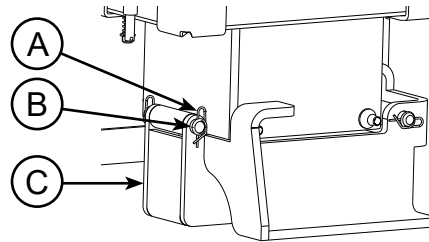

If the Hammer is equipped with the grapple option, it must be removed prior to using the concrete breaker attachment. Follow the instructions below for removing the grapple. If you do not have the grapple option, continue to Step 11.

STEP 10: Using 11/16" and 3/4" wrenches remove the grapple hydraulic hoses (D) from the manifold and plug the holes with two (2) REF. NO. 2 Plugs. Tighten plugs with 1/4" Allen wrench. Using pliers or flathead screwdriver, remove one (1) of the two (2) rue clips (A) on the pin (B) and slide pin out then remove spring (C). Set grapple aside.

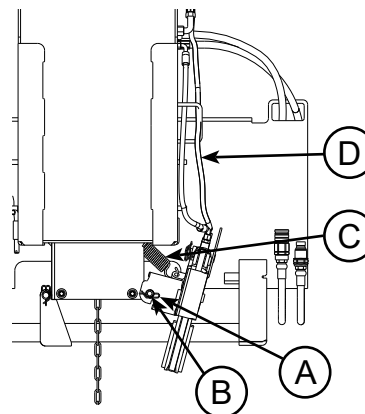

⚠ WARNING

Before connecting or disconnecting hydraulic lines or fittings, be sure to relieve all pressure by cycling all hydraulic controls after shutdown. Remember hydraulic systems are under pressure whenever the engine is running and may hold pressure after shutdown.

Assembly & Installation

(continued)

STEP 11: One set of holes on the REF. NO. 4 Foot Assembly is lower than the other set. Align the lower set of holes with the right side of the Hammer.

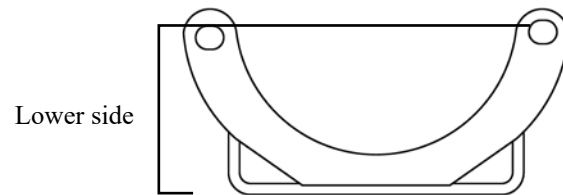

STEP 12: On left side of foot, reinstall the previously removed pin (B) with two (2) rue clips (A). On right side of the foot, install REF. NO. 1 Pin (C) along with two (2) REF. NO. 5 Bosses (Spacers). Install two (2) previously removed rue clips (A) on the new pin.

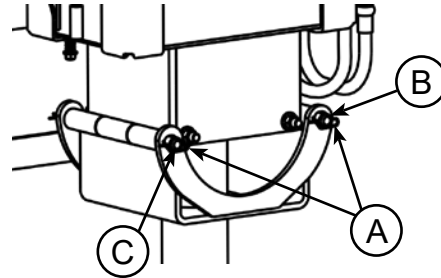

STEP 13: Using the vehicle, slowly tilt the Hammer to the upright position.

STEP 14: Grease all faces of the breaker weight.

STEP 15: Insert a hook into the lifting eye located on the top of the breaker weight. (A) Lift the breaker weight with a hoist, forklift, or another vehicle, and lower the breaker weight into the Hammer with the catch (B) facing the rear (towards the vehicle).

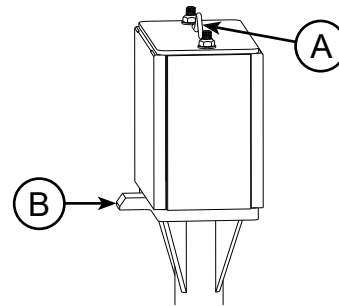

STEP 16: Reinstall the retention pin (A) and rue clip (B).

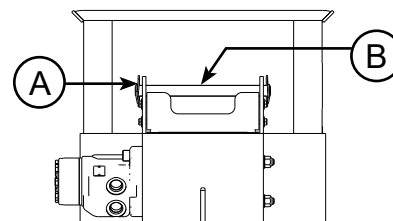

⚠ WARNING

Do not operate the Hammer without the retention pin in place. The breaker weight could slide out of the Hammer and cause serious injury or death.

Assembly & Installation

(continued)

STEP 17: Install the three safety signs included with the breaker kit.

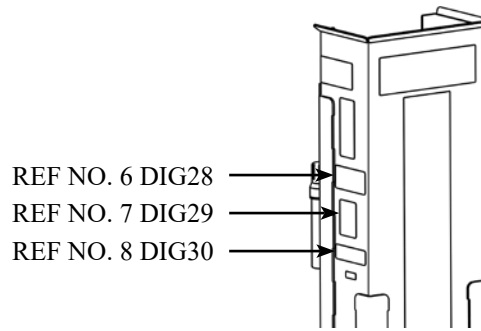

Operation

! DANGER

The Hammer is designed to be operated from the vehicle operator station. Keep bystanders away from the work area. Do not operate with another person in contact with any part of the Hammer.

! DANGER

Do not allow riders on the equipment at any time. There is no safe place for any riders.

! WARNING

Personal protection equipment including hard hat, safety glasses, safety shoes, gloves, and hearing protection are recommended during assembly, installation, operation, maintenance, service, removal, or movement of the attachment.

! WARNING

Carry the load low. A heavy load can cause instability of the vehicle. Use extreme care during travel. Slow down on turns and watch out for bumps. Use all safety devices, including a seat belt, as recommended in the vehicle operator's manual.

! DANGER

Contact with underground gas lines or electrical cables may result in serious injury or death from explosion or electrical shock. Before operating, call 811 or the local number to locate underground utilities. Do not operate near underground utility lines.

! DANGER

Stay away from power lines when transporting, raising, or operating the attachment. Electrocutation can occur without direct contact.

! WARNING

Before you operate the attachment, check over pins and connections to be sure all are securely in place. Make sure the Hammer is securely latched to the vehicle.

STEP 1: Move the vehicle into position with the loader arms raised and the Hammer positioned directly over the concrete to be broken.

STEP 2: Lower the Hammer until it is approximately two to three inches (2"-3") off of the concrete. This means the breaker weight will be slightly pushed up into the housing.

STEP 3: The Hammer can now be activated by activating the auxiliary hydraulics to the forward position.

Operation

(continued)

WARNING

Safe operation of equipment requires the operator's full attention. Avoid distractions such as radio headphones, cell phones, etc. while operating.

WARNING

Never place yourself between the vehicle and the attachment. Never allow anyone under the attachment at any time.

WARNING

Keep hands, feet, hair, jewelry, and clothing away from all moving and/or rotating parts.

STEP 4: Once the concrete is broken, continue to cycle the breaker weight as the vehicle is repositioned. For best results, move back three to six inches (3"-6") at a time. Be sure to stop the vehicle before the breaker weight drops again.

NOTE

Depending on the thickness and strength of the concrete, it may take two or more hits to fracture.

STEP 5: Break concrete to the desired extent, and deactivate the auxiliary hydraulics. Raise the Hammer until the ground is cleared, and move to the next area.

NOTE

As soon as the weight is released (starts to drop), deactivate the auxiliary hydraulics.

NOTE

When stopping the Hammer, the weight catch should be visible through the viewing slots on the back of the case. Never stop the Hammer with the breaker weight partially raised.

CAUTION

Do not leave breaker weight partially raised. Dry firing may occur. Repeated dry firing of breaker weight will cause severe damage to attachment and void all warranties.

Removal & Storage

DANGER

Never allow anyone under the attachment at any time.

WARNING

Personal protection equipment including hard hat, safety glasses, safety shoes, gloves, and hearing protection are recommended during assembly, installation, operation, maintenance, service, removal, or movement of the attachment.

CAUTION

Always use two people to handle heavy, unwieldy components during assembly, installation, maintenance, service, removal, or movement of the attachment.

Before storage, the Hammer should be thoroughly cleaned, washing off all dirt and grime. Make sure the hydraulic system is properly sealed against contaminants entering the unit. Always store the Hammer in a dry, covered location.

STEP 1: Lower the Hammer onto a flat, level surface in an area where children do not play.

STEP 2: Disconnect the hydraulic hoses from the vehicle's auxiliary hydraulics.

WARNING

Before connecting or disconnecting hydraulic lines or fittings, be sure to relieve all pressure by cycling all hydraulic controls after shutdown. Remember hydraulic systems are under pressure whenever the engine is running and may hold pressure after shutdown.

NOTE

Connect the quick couplers together to prevent contaminants from entering the Hammer hydraulic system.

STEP 3: Follow your vehicle operator's manual for removing an attachment.

STEP 4: Tighten any loose nuts, bolts, and hydraulic components.

STEP 5: Replace any damaged or missing safety signs.

STEP 6: Lubricate the drive chain, and grease all zerks.

Troubleshooting

Problem	Possible Cause	Solution
Weight is dropping unexpectedly	Weight is partially raised	When finished breaking, make sure weight is down and weight catch is visible through viewing slots. Refer to <i>Operation</i> .
Weight not cycling	Hammer is not lowered to the ground	The breaker weight must be pushed up inside the Hammer until it stops before the weight will cycle.
	Broken or missing shaft key	Replace key.
	Channel is not lubricated	Grease the inside of the Hammer case.
	Motor damaged	Contact Danuser.
Motor will not operate	Incorrect hose routing	Refer to <i>Hydraulics</i> for proper hose routing.
	Motor damaged	Contact Danuser.
Chain jumps	Incorrect chain tension	Adjust chain tension.
	Sprockets or chains are worn	Replace worn item(s).
Oil over heating	High flow activated	Ensure vehicle is not in high flow mode.
	Low oil level	Fill reservoir to proper level.
	Dirty oil or oil filter	Change oil and filter.

For additional assistance, please call your dealer or contact Danuser direct:

Tel: (573) 642-2246

E-mail: sales@danuser.com

Maintenance & Lubrication

! DANGER

Never attempt adjustments, service, or repairs while the equipment is in operation.

! DANGER

Never allow anyone under the attachment at any time.

! DANGER

Never work under equipment supported by hydraulics. Even with the vehicle shut off, equipment can suddenly drop if controls are actuated or if hydraulic lines burst.

! WARNING

Personal protection equipment including hard hat, safety glasses, safety shoes, gloves, and hearing protection are recommended during assembly, installation, operation, maintenance, service, removal, or movement of the attachment.

! WARNING

Before servicing or adjusting attachment, relieve all stored energy.

Proper servicing and maintenance are key to the long life of any attachment. Careful inspection and routine maintenance helps avoid costly downtime and repair. Do not use the Hammer with any damaged parts.

! WARNING

Never check pressurized system for leaks with your bare hand. Wear proper hand and eye protection and use wood or cardboard when searching for suspected leaks. Oil escaping from pinhole leaks under pressure can penetrate skin and create a serious medical emergency. If any fluid is injected into the skin, gangrene, blood poisoning, even death may result. Obtain medical attention immediately.

! WARNING

Do not modify the attachment. Modifications may weaken the integrity of the attachment and may impair the safety, function, life, and performance of the Hammer.

! CAUTION

When making repairs or servicing the Hammer, use only parts that meet original equipment manufacturer's standards and requirements.

Maintenance	Interval
Inspect the attachment for any damage, worn parts, or cracked welds. Repair or replace as necessary.	Before each use
Check for damaged or missing safety signs. Replace as necessary.	Before each use
Check all fasteners. Ensure they are tight and secure. (Refer to <i>Torque Values Chart</i> .) Replace as necessary.	Daily
Check all hydraulic components for leaks or wear. Repair or replace as necessary.	Daily
Check for clean hydraulic oil. At all times, keep dirt and other contaminants from entering the hydraulic system during connecting and disconnecting the hydraulic system. Always use dust caps and plugs on all quick disconnects when not in use.	Daily
Visually inspect all welds for cracks. Check the weight catch for wear. Check all bolts and fasteners for tightness.	Every 40 Hours
Inspect the chain tensioning springs. Springs should be preloaded but not entirely collapsed.	Every 40 Hours

Maintenance & Lubrication

(continued)

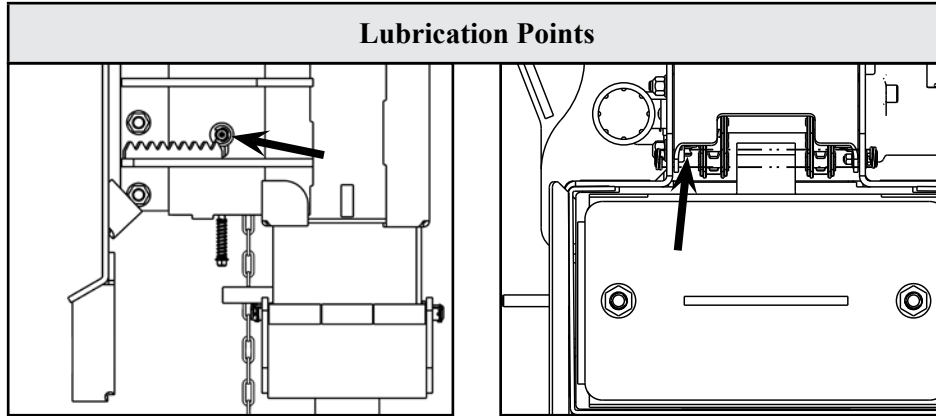

Chain Sprocket Shaft - 1 Zerk

Add multi-purpose grease until grease emerges

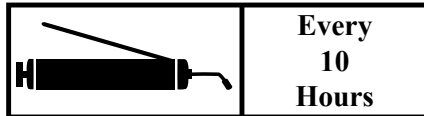

Drive Chain Bearing - 1 Zerk

Add multi-purpose grease until grease emerges

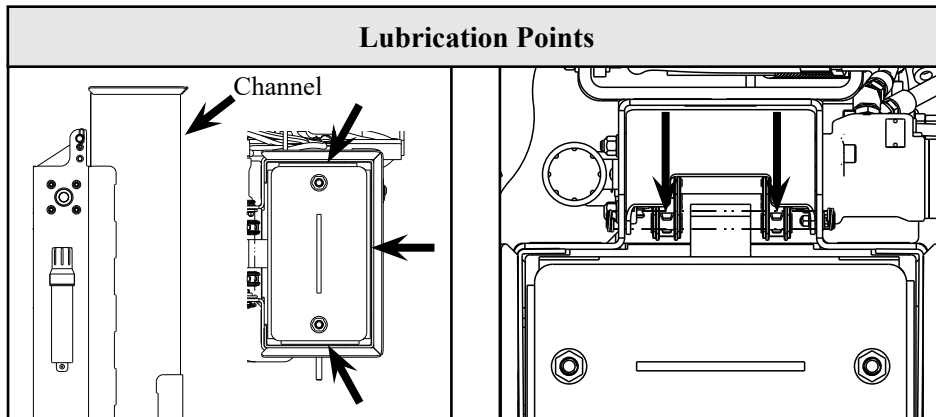
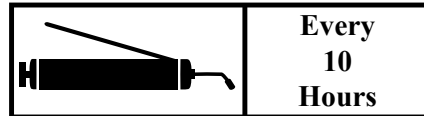

Drive Channel - 3 Channel Sides

Lubricate drive channel with multi-purpose grease



Drive Chain - 2 Chains

Lubricate drive chain with commercial grade chain lubricant

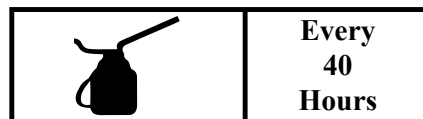

Service

Replacing Drive Chain

! DANGER

Never attempt adjustments, service, or repairs while the equipment is in operation.

! DANGER

Never allow anyone under the attachment at any time.

! DANGER

Never work under equipment supported by hydraulics. Even with the vehicle shut off, equipment can suddenly drop if controls are actuated or if hydraulic lines burst.

! WARNING

Personal protection equipment including hard hat, safety glasses, safety shoes, gloves, and hearing protection are recommended during assembly, installation, operation, maintenance, service, removal, or movement of the attachment.

! WARNING

Before servicing or adjusting attachment, relieve all stored energy.

! CAUTION

Always use two people to handle heavy, unwieldy components during assembly, installation, maintenance, service, removal, or movement of the attachment.

Recommended Tools

- 7/16" wrench (2)
- 9/16" wrench
- Flat-head screwdriver
- Pliers

STEP 1: Ensure the breaker weight is not partially raised by making sure the weight catch is visible through the viewing slots on the back of the case.

STEP 2: Remove the retention pin from the top of the case. Insert a hook into the lifting eye located on the top of the breaker weight. Lift the breaker weight out of the Hammer with a hoist, forklift, or another vehicle. Set the breaker weight on the ground.

STEP 3: Carefully lay down the Hammer on its front side.

STEP 4: Remove the top and bottom chain covers.

STEP 5: Remove the retaining ring fastened to the lower sprocket shaft assembly, and pull out the shaft from the opposite side of the Hammer.

STEP 6: Remove the tensioning rods and shim(s). Slide chain slack to the top of the Hammer.

STEP 7: Find the chain catch and two pins that secure it. Remove the clips that retain the pins, and remove the pins.

STEP 8: Install new chains over the upper sprocket shaft assembly. Make sure open ends of the chain are at equal links away from sprockets.

STEP 9: Reinstall the chain catch and pins through the open ends of the new chain. Install clips on the pins.

STEP 10: Slide chain slack to the bottom of the Hammer, and insert the lower sprocket shaft assembly into the chain.

NOTE

Shim(s) must be inserted between the tensioning rods and the lower sprocket shaft assembly to maintain proper sprocket location.

STEP 11: Insert the lower sprocket shaft through the side of the Hammer and through the tensioning rods and sprockets.

STEP 12: Install shim(s) and retaining ring on the end of the sprocket shaft.

STEP 13: Install bottom chain guard and tensioning springs. Tighten tensioning nuts until the springs are adequately preloaded but not entirely collapsed (approximately 1.5").

STEP 14: Install the top chain cover, stand Hammer upright, reinstall breaker weight, and install the retention pin.

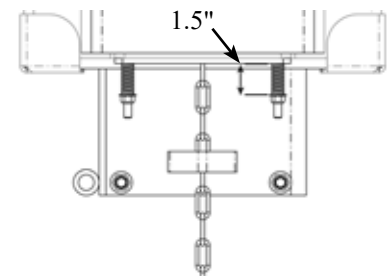

Tighten tensioning nuts until springs are adequately preloaded

! WARNING

Do not operate the Hammer without the retention pin in place. The breaker weight could slide out of the Hammer and cause serious injury or death.

Torque Values Chart

Torque Values Chart																	
Bolt Size (inches)	Bolt Head Identification								Bolt Size (Metric)	Bolt Head Identification							
	Grade 2		Grade 5		Grade 8		ASTM A574			5.8	Class 8.8		Class 10.9		Class 12.9		
in-tpi	Nm	ft.-lb.	Nm	ft.-lb.	Nm	ft.-lb.	Nm	ft.-lb.	mm x pitch	Nm	ft.-lb.	Nm	ft.-lb.	Nm	ft.-lb.	Nm	ft.-lb.
1/4"-20	7.4	5.6	11	8	16	12	19	14	M5 x 0.8	4	3	6	5	9	7	11	8
1/4"-28	8.5	6	13	10	18	14	22	16	M6 x 1	7	5	11	8	15	11	18	13
5/16"-18	15	11	24	17	33	25	39	29	M8 x 1.25	17	12	26	19	36	27	42	31
5/16"-24	17	13	26	19	37	27	43	32	M8 x 1	18	13	28	21	39	29	46	34
3/8"-16	27	20	42	31	59	44	69	51	M10 x 1.5	33	24	52	39	72	53	84	62
3/8"-24	31	22	47	35	67	49	79	58	M10 x 0.75	39	29	61	45	85	62	98	72
7/16"-14	43	32	67	49	95	70	110	81	M12 x 1.75	58	42	91	67	125	93	148	109
7/16"-20	49	36	75	55	105	78	123	91	M12 x 1.5	60	44	95	70	130	97	153	113
1/2"-13	66	49	105	76	145	105	168	124	M12 x 1	90	66	105	77	145	105	167	123
1/2"-20	75	55	115	85	165	120	190	140	M14 x 2	92	68	145	105	200	150	235	173
9/16"-12	95	70	150	110	210	155	235	173	M14 x 1.5	99	73	155	115	215	160	254	187
9/16"-18	105	79	165	120	235	170	262	193	M16 x 2	145	105	225	165	315	230	365	269
5/8"-11	130	97	205	150	285	210	323	238	M16 x 1.5	155	115	240	180	335	245	388	286
5/8"-18	150	110	230	170	325	240	366	270	M18 x 2.5	195	145	310	230	405	300	504	372
3/4"-10	235	170	360	265	510	375	574	423	M18 x 1.5	220	165	350	260	485	355	561	414
3/4"-16	260	190	405	295	570	420	640	472	M20 x 2.5	280	205	440	325	610	450	712	525
7/8"-9	225	165	585	430	820	605	925	682	M20 x 1.5	310	230	650	480	900	665	1052	776
7/8"-14	250	185	640	475	905	670	1020	752	M24 x 3	480	355	760	560	1050	780	1231	908
1"-8	340	250	875	645	1230	910	1386	1022	M24 x 2	525	390	830	610	1150	845	1337	986
1"-12	370	275	955	705	1350	995	1555	1147	M30 x 3.5	960	705	1510	1120	2100	1550	2447	1805
1-1/8"-7	480	355	1080	795	1750	1290	1971	1454	M30 x 2	1060	785	1680	1240	2320	1710	2706	1996
1-1/8"-12	540	395	1210	890	1960	1440	2202	1624	M36 x 3.5	1730	1270	2650	1950	3660	2700	4272	3151
1-1/4"-7	680	500	1520	1120	2460	1820	2771	2044	M36 x 2	1880	1380	2960	2190	4100	3220	5095	3758
1-1/4"-12	750	555	1680	1240	2730	2010	3068	2263	KEY: in-tpi = nominal thread diameter in inches-threads per inch Nm = Newton-meter ft.-lb. = foot pounds mm x pitch = nominal thread diameter in millimeters by thread pitch								
1-3/8"-6	890	655	1990	1470	3230	2380	3638	2683									
1-3/8"-12	1010	745	2270	1670	3680	2710	4143	3056									
1-1/2"-6	1180	870	2640	1950	4290	3160	4823	3557									
1-1/2"-12	1330	980	2970	2190	4820	3560	5426	4002									

Torque tolerance +0%, -15% of torque values. Unless otherwise specified, use torque values listed above.

Parts

⚠ CALIFORNIA WARNING

Case, Hammer Weight,
Quick Attach

This product can expose you to chemicals including lead, which are known to the State of California to cause cancer and birth defects or other reproductive harm. For more information go to www.P65Warnings.ca.gov.

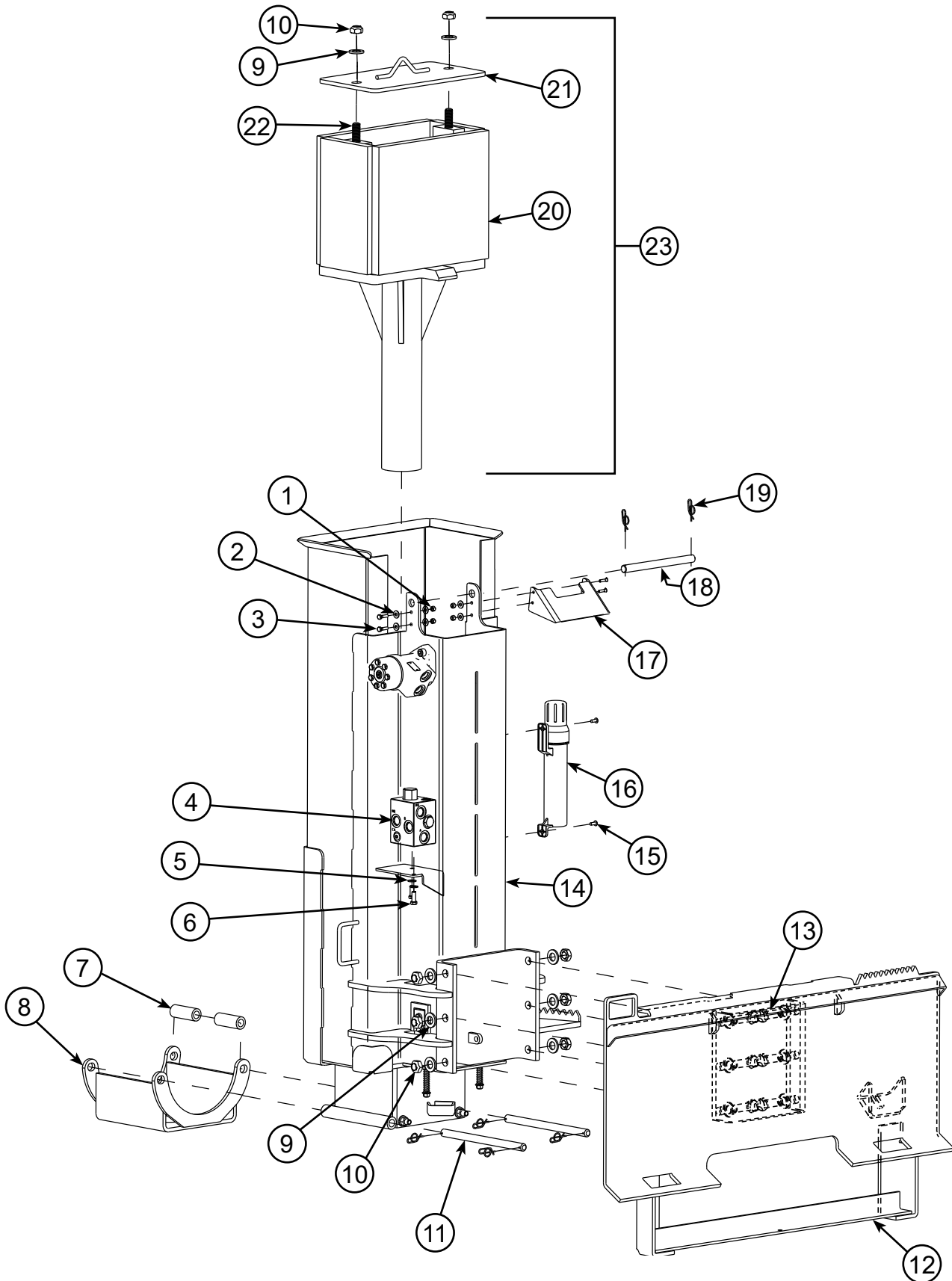

Parts

(continued)

REF. NO.	PART NO.	DESCRIPTION	QTY.
1	10195	Toplock Nut (1/4"-20)	4
2	21056	Flat Washer (1/4")	8
3	21055	Bolt (1/4"-20 x 1", Gr. 5)	4
4	21137	Hydraulic Manifold	1
5	2178	Flat Washer (3/8")	2
6	21157	Bolt (3/8"-16 x 1", Gr. 2)	2
7	21277	Boss (Spacer)	2
8	21274	Foot Assembly	1
9	10267	Flat Washer (3/4")	8
10	10268	Toplock Nut (3/4"-10)	8
11	21079	Pin	2
12	21086S	Quick Attach Plate (Includes decals and safety signs)	1
13	21105	Bolt (3/4"-10 x 2.25", Gr. 5)	6
14	21026	Case	1
15	21259	Drive Rivet	2
16	21258	Operator's Manual Canister	1
17	200280	Cover	1
18	21118	Retention Pin	1
19	21078	Rue Clip	6
20	21271	Weight	1
21	21052	Cover	1
22	21054	Stud (3/4"-10 x 3.25")	2
23	21270	Weight Assembly (Includes REF. NOS. 9, 10, 20-22)	1

Parts

Drive Assembly

⚠ CALIFORNIA WARNING

This product can expose you to chemicals including lead, which are known to the State of California to cause cancer and birth defects or other reproductive harm. For more information go to www.P65Warnings.ca.gov.

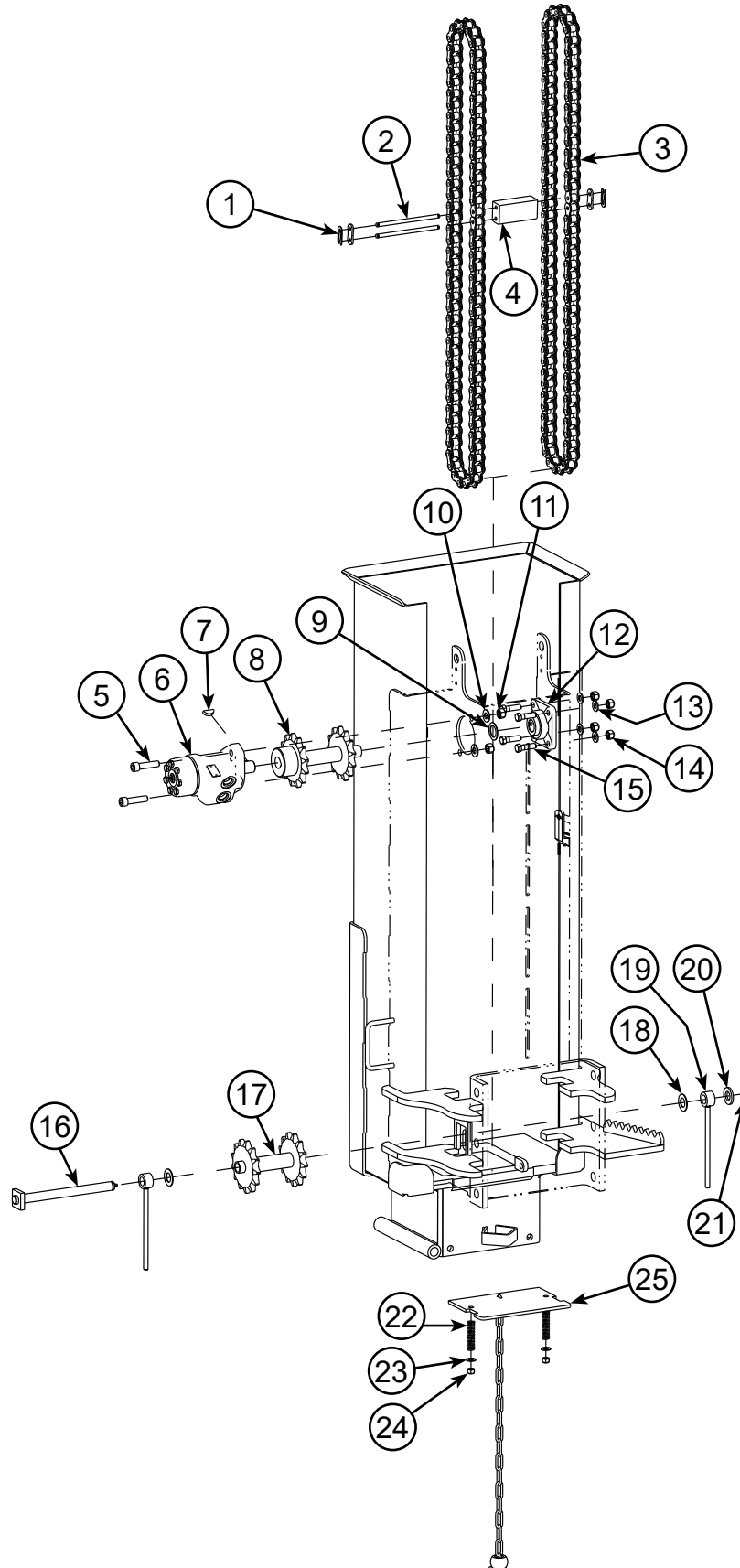

Parts

	REF. NO.	PART NO.	DESCRIPTION	QTY.
(continued)	1	21119	Connecting Link	2
	2	21024	Chain Pin	2
	3	21025	Roller Chain (#80, 1" Pitch)	2
	4	21122	Catch Weight	1
	5	21126	Socket Head Bolt (1/2"-13 x 2")	2
	6	21113	Hydraulic Motor (Includes REF. NO. 7)	1
		20079	Hydraulic Motor Seal Kit (Not Pictured)	
	7	21281	Woodruff Key	1
	8	21114	Upper Sprocket Shaft Assembly	1
	9	21136	Shim (1")	1
	10	21156	Flat Washer (1/2")	2
	11	10125	Toplock Nut (1/2"-13)	2
	12	21043	Bearing	1
	13	2489	Flat Washer (7/16")	4
	14	10197	Nut (7/16"-14)	4
	15	21057	Bolt (7/16"-14 x 1.5", Gr. 5)	4
	16	21040	Sprocket Shaft	1
	17	21080	Lower Sprocket Shaft Assembly	1
	18	21125	Shim	2
	19	21083	Tensioning Rod	2
	20	10267	Flat Washer (3/4")	1
	21	2172	Retaining Ring	1
	22	21123	Spring	2
	23	2178	Flat Washer (3/8")	2
	24	10412	Toplock Nut (3/8"-16")	2
	25	21110	Cover Assembly	1

Parts

Hydraulics

⚠ CALIFORNIA WARNING

This product can expose you to chemicals including lead, which are known to the State of California to cause cancer and birth defects or other reproductive harm. For more information go to www.P65Warnings.ca.gov.

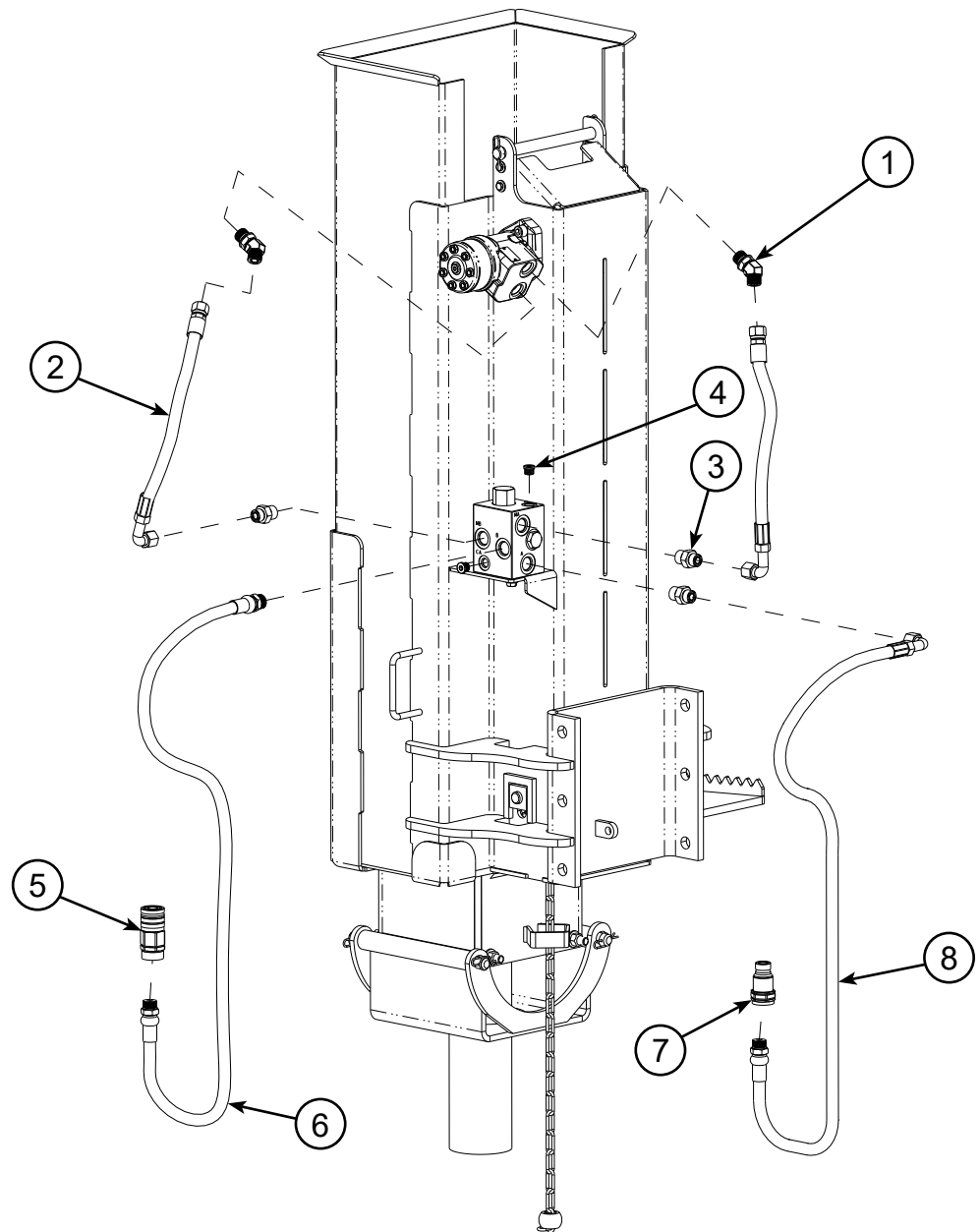

REF. NO.	PART NO.	DESCRIPTION	QTY.
1	196043	Adapter, 45° (#8 ORFS M to #10 ORB M)	2
2	196029	1/2" Hose Assembly (#8 ORFS F to #8 ORFS F 90°)	2
3	196044	Adapter (#8 ORFS M to #10 ORB M)	3
4	21141	Plug (#6 ORB)	2
5	10049	Female Coupler (1/2" flush-face, ISO 16028)	1
6	21139	1/2" Hose Assembly (#10 ORB M Swivel to #10 ORB M)	1
7	10048	Male Coupler (1/2" flush-face, ISO 16028)	1
8	196086	1/2" Hose Assembly (#8 ORFS F 90° to #10 ORB M)	1

Parts

Concrete Breaker Kit

⚠ CALIFORNIA WARNING

This product can expose you to chemicals including lead, which are known to the State of California to cause cancer and birth defects or other reproductive harm. For more information go to www.P65Warnings.ca.gov.

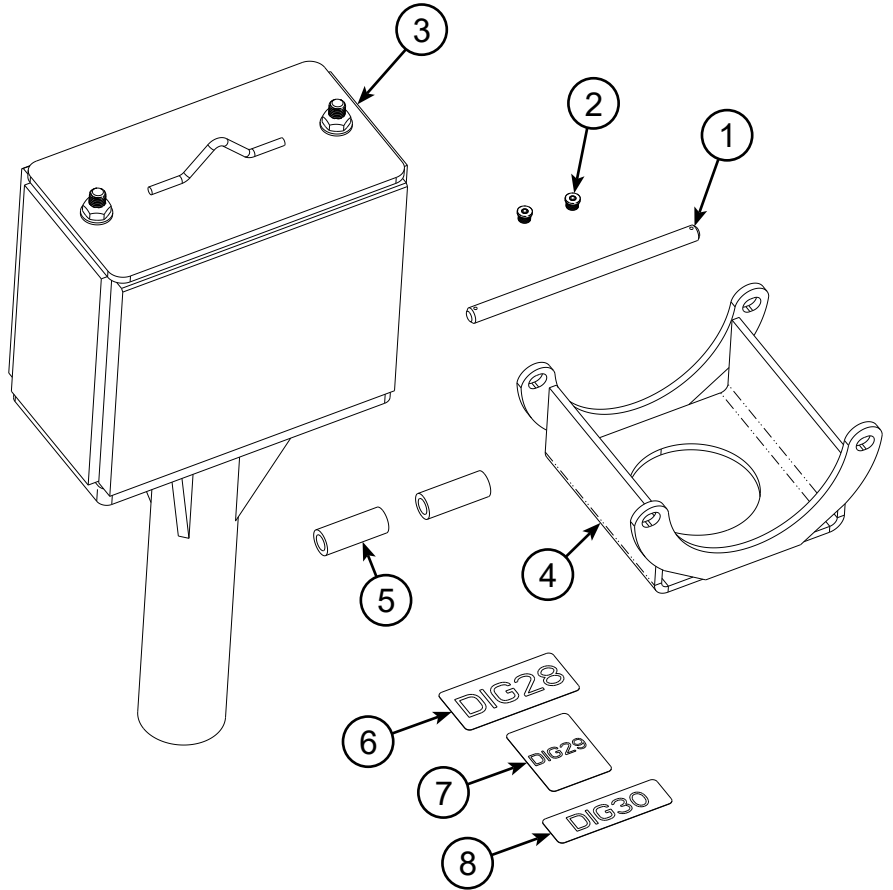

REF. NO.	PART NO.	DESCRIPTION	QTY.
1	21079	Pin	1
2	21141	Plug (#6 ORB)	2
3	21270	Weight Assembly	1
4	21274	Foot Assembly	1
5	21277	Boss (Spacer)	2
6	DIG28	Safety Sign	1
7	DIG29	Safety Sign	1
8	DIG30	Safety Sign	1

Warranty

DANUSER

Model # _____

Serial # _____

LIMITED WARRANTY

Danuser Machine Company, LLC ("Danuser") warrants its products, under normal use and maintenance, to be free from defects in material and workmanship for period(s) specified below from the purchase date from an authorized Danuser Dealer. Start of the warranty period is determined by purchase date given on your returned WARRANTY REGISTRATION FORM. Proof of purchase may be required. This Limited Warranty is extended only to the original purchaser of Danuser products.

Hammer - 1 Year

Wear Items Not Covered Under Warranty - Hydraulic Hoses and Seals

1. During the applicable warranty period, Danuser, at its option, will repair or replace any part determined by Danuser to be defective. Such repair or replacement shall take place at Danuser's factory, or a location designated by Danuser. Under no circumstances shall Danuser be obligated for the cost of any repair or replacement by anyone other than Danuser without its express written consent.
2. Parts may not be returned without written authorization from Danuser.
3. Some purchased components, including but not limited to hydraulic components, are subject to the inspection and warranty of the respective manufacturer. Thus, delays in a warranty determination can be expected while Danuser awaits their decision.
4. This warranty is void if any attempt is made to make field repairs to hydraulic components. To qualify for warranty inspection, the "failed" part(s) must be returned in its original "failed" condition.
5. To make a claim under this warranty, you may either contact your authorized Danuser Dealer or initiate a claim directly with Danuser. In either case, a Warranty Claim Form must be completed and written authorization from Danuser obtained prior to returning parts. All warranty claims must include detailed information regarding make and model of vehicle on which the Danuser product was mounted, hours of use, description of events that led up to the failure, and any other information helpful in reviewing the warranty claim. All warranty returns must be prepaid. Shipments arriving at our factory on a freight collect basis will be refused by our receiving department. The freight charge will be credited if the parts are determined by Danuser to be defective, and the associated freight costs in returning those parts will be prepaid by Danuser. NOTE: Hydraulic components must arrive with all ports sealed from dirt and moisture. If a hydraulic component arrives with open ports, the warranty is void and no inspection will be made.
6. Products or parts thereof which, as determined by Danuser's examination, show wear from normal use, have been improperly operated, damaged by accident or negligence, field repaired, altered or modified are not considered defective in material and workmanship and are not covered by this warranty. This warranty does not apply to parts subject to normal wear ("Wear Items") or to damage caused by the failure to perform recommended maintenance or to replace worn parts. This warranty shall not obligate Danuser to bear any cost of labor for field repair, replacement, testing, or adjustment nor for damage caused by accident, abuse, misuse, or environmental elements.
7. Any parts or labor required to repair or replace parts not covered under this warranty will be charged to the customer. Parts repaired or replaced by Danuser are then covered by this warranty only for the remainder of the original warranty as if such parts were original parts.
8. Danuser reserves the right to change its specifications and designs at any time.

This warranty is exclusive and in lieu of all other express warranties, if any, including the implied warranties of merchantability and fitness for a particular purpose. It shall not extend beyond the duration of the expressed warranty provided herein and the remedy for violations of any implied warranty shall be limited to repair or replacement of the defective part pursuant to the terms contained herein. No employee, dealer, salesman, or representative is authorized to change this warranty in any way or grant any other warranty. Danuser shall not be liable for any consequential, incidental, or punitive damages, losses, or expenses, including those resulting from or caused by any defects.

Danuser Machine Company, LLC
500 E. 3rd St.
P.O. Box 368
Fulton, MO 65251

Tel: (573) 642-2246
E-mail: sales@danuser.com
Website: www.danuser.com

PD 5034B