

PYTHON[®] WIRE UNROLLER



⚠ Read this entire manual. This safety alert symbol is used throughout this manual to call your attention to messages involving your personal safety and the safety of others. Failure to follow these instructions can result in injury or death.

⚠ WARNING

Si no entiende ingles, se prefiere que busque a alguien que interprete las instrucciones para usted.

Owner: _____

Date Purchased: _____

Manual #: 9MPYTHONWU2461097

Operator's Manual

Danuser Machine Company, LLC
500 E. 3rd St.
P.O. Box 368
Fulton, MO 65251
Tel: (573) 642-2246
E-mail: sales@danuser.com
Website: www.danuser.com



Dear Owner/Operator,

Thank you for purchasing this Danuser Python Wire Unroller. We appreciate your business.

The Python Wire Unroller is designed to meet the needs of farmers, ranchers, and fencing professionals. The Python Wire Unroller connects to a 2" receiver hitch and accepts most new spools of wire or wire spooled using the Python Wire Winder.

Your safety as an operator of our product is very important to us. Therefore, *before* you assemble, install, operate, maintain, remove, or move your Danuser Python Wire Unroller, read and understand this manual thoroughly. If there is anything you do not understand, immediately contact your dealer, or contact our factory direct.

Tel: (573) 642-2246

E-mail: sales@danuser.com

Your satisfaction in the performance and longevity of our product is also very important to us and can be prolonged by proper assembly, installation, operation, and maintenance as instructed in this manual.

Thank you again for your business and for your trust in our product. Please feel free to contact us at any time for further assistance.

Sincerely,

Danuser Machine Company, LLC
500 E. 3rd St.
P.O. Box 368
Fulton, MO 65251

Tel: (573) 642-2246

E-mail: sales@danuser.com Website: www.danuser.com

Danuser provides this manual "as is" without warranty of any kind, either expressed or implied. Danuser assumes no responsibility for errors or omissions. Danuser assumes no liability for damages resulting from the use of the information contained herein. Danuser reserves the right to revise and improve its products as it sees fit. This manual describes the state of this product at the time of its publication and may not reflect the product in the future.

Danuser is a registered trademark.

Foreword

Please read this manual thoroughly!

Before you assemble, install, operate, maintain, remove, or move your Danuser Python Wire Unroller, read this manual thoroughly. If there is anything you do not understand, immediately contact your dealer, or call our factory direct at (573) 642-2246. Powered equipment can be dangerous if not assembled, installed, operated, maintained, removed, or moved properly.

Symbols



This SAFETY ALERT symbol identifies important safety messages. Carefully read each safety message that follows. Failure to understand and obey a safety message, or recognize a safety hazard, could result in injury or death to you or others around you. The operator is ultimately responsible for the safety of himself, as well as others, in the operating area of the wire unroller.





<i>Symbol</i>	<i>Meaning</i>
	Indicates an imminently hazardous situation which, if not avoided, will result in death or serious injury.
	Indicates a potentially hazardous situation which, if not avoided, could result in death or serious injury, including hazards that are exposed when guards are removed.
	Indicates a potentially hazardous situation which, if not avoided, may result in minor or moderate injury. It may also be used to alert against unsafe practices.
	This is important information for proper use of this equipment. Failure to comply may lead to premature equipment failure.

Table of Contents

	Page
Letter to Owner/Operator	2
Foreword	3
Symbols	3
Safety	4
Decals & Safety Signs	7
Specifications	8
Assembly & Installation	9
Operation	10
Removal & Storage	15
Troubleshooting	16
Maintenance	17
Parts	18
Python Wire Winder	19
Warranty	PD 5163

WARNING

Working with unfamiliar equipment can lead to careless injuries. Read and understand this manual and the manual for your vehicle before assembling, installing, operating, maintaining, removing, or moving this wire unroller. If there is anything in this manual you do not understand, contact your dealer or Danuser. The safe use of this equipment is strictly up to you, the operator. If this wire unroller is used, loaned, or rented by any other person, it is the owner's responsibility to make certain that the operator prior to operating:

- Reads and understands the Operator's Manuals
 - Is instructed in safe and proper use
-
- This wire unroller is designed to be used in conjunction with a 2" receiver hitch mounted to the rear of the vehicle.
 - It is the responsibility of the operator to see that no one is within twenty-five feet (25') of the wire unroller or wire path before and during wire unroller rotation. Do not operate the wire unroller with another person near or in contact with any part of the wire unroller. Serious personal injury or death may result if any attempt is made to assist unrolling operations by hand.
 - All operators of this attachment must read and understand this entire manual, paying particular attention to safety messages and operation instructions, prior to assembling, installing, operating, maintaining, removing, or moving the wire unroller.
 - Please remember it is also important that you read, understand, and follow the safety signs on the attachment. Clean or replace all safety signs if they cannot be clearly read and understood. They are there for your safety as well as the safety of others. Danuser will furnish new safety signs upon request at no charge.
 - All things with moving parts are potentially hazardous. There is no substitute for a cautious, safe-minded operator who recognizes potential hazards and follows reasonable safety practices.
 - Personal protection equipment including safety glasses, hearing protection, safety shoes, and gloves are recommended during assembly, installation, operation, maintenance, removal, or movement of the wire unroller.
 - When the use of hand tools is required to perform any part of assembly, installation, maintenance, removal, or movement of the wire unroller, be sure the tools used are designed and recommended by the tool manufacturer for that specific task.
 - Always use two people to handle heavy, unwieldy components during assembly, installation, maintenance, removal, or movement of the wire unroller.

Safety

(continued)

- Never place any part of your body where it would be in danger if movement should occur during assembly, installation, operation, maintenance, removal, or movement of the wire unroller.
- Never exceed the rated trailer tongue weight of the vehicle hitch.
- Never transport the wire unroller on highways while connected to vehicle hitch.
- Only properly trained people should operate this equipment. Do not allow anyone who has not read this entire manual and understood the safety rules, safety signs, and operation instructions to use this wire unroller.
- Never allow children to operate or be around this wire unroller.
- Do not allow riders on the equipment at any time. There is no safe place for any riders.
- Never use alcoholic beverages or drugs which can hinder alertness or coordination while operating this equipment. Consult your doctor about operating this equipment while taking prescription or over-the-counter medications.
- Safe operation of equipment requires the operator's full attention. Avoid distractions such as radio headphones, cell phones, etc. while operating.
- Before beginning operation, clear the work area of objects which might be picked up and thrown by or entangled in the wire and/or wire unroller.
- Before you operate the attachment, check over all pins, bolts, and connections to be sure all are securely in place. Replace any damaged or worn parts immediately.
- Never replace the top plate assembly retaining pin with anything other than one that meets the original equipment manufacturer's standards and requirements. A longer, or protruding, fastener is more likely to grab clothing or gloves, which can result in serious injury or death.
- Keep all helpers and bystanders twenty-five feet (25') away from the operating attachment and the wire path.
- Keep hands, feet, hair, jewelry, and clothing away from all moving and/or rotating parts.
- Never place yourself between the vehicle and the attachment.
- Never manually guide wire by hand or with tool.
- Never exceed 10 MPH while unrolling wire.

Safety

(continued)

- Stay clear of wire path during tensioning. Wire may come loose or break, potentially injuring bystanders.
- A heavy load can cause instability of the vehicle. Use extreme care during travel. Slow down on turns and watch out for bumps. Use all safety devices, including a seat belt, as recommended in the vehicle operator's manual.
- Never attempt adjustments, service, or repairs while the attachment is in operation.
- Store the wire unroller on a flat, level surface in an area where children do not play. Securely block and support the wire unroller.
- Do not modify the wire unroller. Modifications may weaken the integrity of the wire unroller and may impair the safety, function, life, and performance of the wire unroller.
- When maintaining the wire unroller, use only parts that meet original equipment manufacturer's standards and requirements.
- Always use care when operating the wire unroller. Most accidents occur because of neglect or carelessness.

Safety is a primary concern in the design, manufacture, sale, and use of the wire unroller. Danuser confirms to you, our customer, our concern for safety.

DANGER

Improper operation of this wire unroller can cause serious personal injury or death. Operation of this wire unroller should only be done by a competent adult acting in compliance with the Operator's Manual. Since unrolling operations are beyond our control, we disclaim all liability for any damages, injuries, or death which may result.

CALIFORNIA WARNING

This product can expose you to chemicals including lead, which are known to the State of California to cause cancer and birth defects or other reproductive harm. For more information go to www.P65Warnings.ca.gov.

Decals & Safety Signs

The Python Wire Unroller comes equipped with all safety signs in place. Their locations are shown in this section. Read and follow their instructions and ensure their care:

- Keep safety signs clean and legible at all times.
- Replace safety signs that are missing, illegible, or damaged.

⚠️ WARNING

Clean or replace all safety signs if they cannot be clearly read and understood.

To install new safety signs, follow these steps:

1. Clean the area where the safety sign is to be placed.
2. Spray a little soapy water on the surface where the safety sign is to be placed.
3. Peel the backing from the safety sign and apply it in the position shown.
4. Firmly press the safety sign and squeeze out the air bubbles with a straight edge (e.g., a credit card).

PART NO. DIG53

Location: Frame, top



PART NO. 190000

Location: Spool Assembly, center column

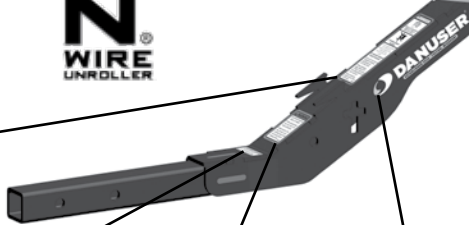
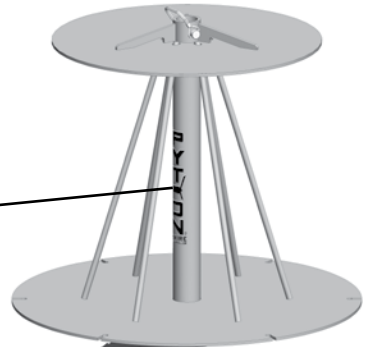

PART NO. CA65

Location: Frame, top



PART NO. DIG54

Location: Frame, top



PART NO. DANUSER106

Locations: Frame, both sides

Specifications

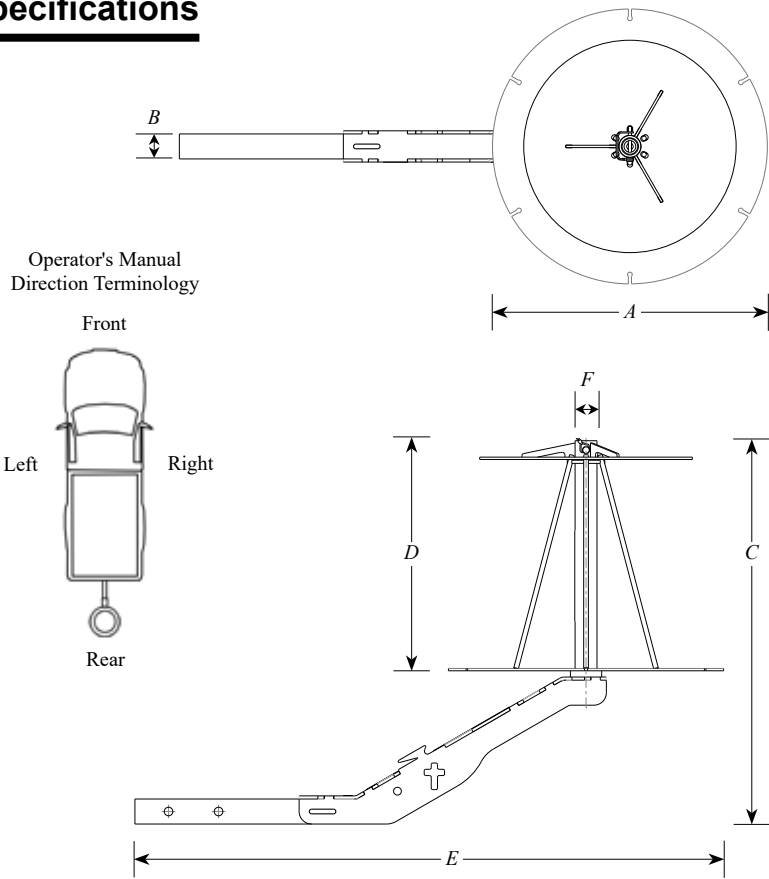

Operator's Manual
Direction Terminology

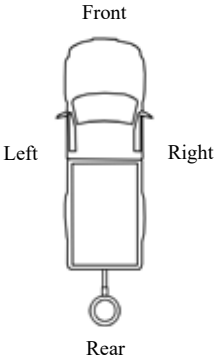

Python Wire Unroller	
Spool Assembly Diameter (A)	22"
Frame Width (B)	2"
Overall Height (C)	30.75"
Spool Assembly Height (D)	16.75"
Overall Length (E)	47"
Minimum Wire Spool Inner Diameter (F)	1.25"
Weight	69 lb.
Wire Capacity	Up to 3/4 mile barbed Up to 6 miles smooth
Mounting Option	2" receiver hitch

Assembly & Installation

WARNING

Personal protection equipment including safety glasses, hearing protection, safety shoes, and gloves are recommended during assembly, installation, operation, maintenance, removal, or movement of the wire unroller.

CAUTION

Always use two people to handle heavy, unwieldy components during assembly, installation, maintenance, removal, or movement of the wire unroller.

Prepare the Vehicle

Read and understand the manual for your vehicle before installing or using the Python Wire Unroller. This wire unroller is designed to be used in conjunction with a 2" receiver hitch mounted to the rear of the vehicle.

Recommended Tools

- Box/band cutter

- STEP 1: Remove pallet, banding, zip-ties, and any other packaging materials.
- STEP 2: Remove trailer hitch from vehicle receiver hitch.
- STEP 3: Insert unroller frame into vehicle trailer hitch spool-side-up. Secure in place using pin and keeper removed from trailer hitch ball.
- STEP 4: Verify there is sufficient clearance between vehicle tailgate, bumper, and any other overhanging structure and the Python Wire Unroller to allow proper operation and visibility. Do not use devices that may collide with and damage the unroller, such as a UTV dump bed, while the unroller is attached.

WARNING

Never exceed the rated trailer tongue weight of the vehicle hitch.

Operation

Unrolling New Wire

⚠ DANGER

It is the responsibility of the operator to see that no one is within twenty-five feet (25') of the wire unroller or wire path before and during wire unroller rotation. Do not operate the wire unroller with another person near or in contact with any part of the drive unit or wire unroller. Serious personal injury or death may result if any attempt is made to assist unrolling operation by hand.

⚠ WARNING

Personal protection equipment including safety glasses, hearing protection, safety shoes, and gloves are recommended during assembly, installation, operation, maintenance, removal, or movement of the wire unroller.

⚠ WARNING

Safe operation of equipment requires the operator's full attention. Avoid distractions such as radio headphones, cell phones, etc. while operating.

⚠ DANGER

Do not allow riders on the equipment at any time. There is no safe place for any riders.

⚠ WARNING

Never transport the wire unroller on highways while connected to vehicle hitch.

⚠ WARNING

Before you operate the attachment, check over all pins, bolts, and connections to be sure all are securely in place. Replace any damaged or worn parts immediately.

- STEP 1: Shut off the vehicle engine, set the parking brake, and remove the vehicle key.
- STEP 2: Remove spool top plate retaining pin, top plate, and spool assembly. Set spool assembly and retaining pin aside. Invert top plate, and slide down over frame spindle so that its flat surface faces upwards.



NOTE

Ensure the rubber brake pad is installed on the spindle below top plate.

- STEP 3: Check that new spool of wire has sufficient inner diameter to fit over spindle (refer to *Specifications*). Slide spool of wire over spindle, and gently set spool down onto top plate.

⚠ DANGER

Before beginning operation, clear the work area of objects which might be picked up and thrown by or entangled in the wire and/or wire unroller.

Operation

(continued)

⚠ DANGER

Never place yourself between the vehicle and the attachment.

⚠ WARNING

Keep hands, feet, hair, jewelry, and clothing away from all moving and/or rotating parts.

STEP 4: Attach wire to starting post, and slowly drive forward to unroll wire.

⚠ DANGER

Never manually guide wire by hand or with tool.

⚠ CAUTION

Never exceed 10 MPH while unrolling wire.

NOTE

Excessive speed while unrolling may cause the wire spool to over-spin and become tangled. Should that occur, come to a stop, back up slightly to relieve tension on the wire, and untangle the wire before continuing to unroll.

⚠ DANGER

Keep all helpers and bystanders twenty-five feet (25') away from the wire unroller or wire path before and during wire unroller rotation. The wire unroller must be positioned such that all winding operations, including the wire path, can be easily seen.

STEP 5: Upon reaching the end post, wrap the wire around the cleats on the frame of the unroller. Slowly drive forward to put tension on the wire.



⚠ WARNING

Stay clear of wire path during tensioning. Wire may come loose or break, potentially injuring bystanders.

Operation

(continued)

Operation

Unspooling Python Wire
Winder-Spooled Wire

⚠ DANGER

It is the responsibility of the operator to see that no one is within twenty-five feet (25') of the wire unroller or wire path before and during wire unroller rotation. Do not operate the wire unroller with another person near or in contact with any part of the drive unit or wire unroller. Serious personal injury or death may result if any attempt is made to assist unrolling operation by hand.

⚠ WARNING

Personal protection equipment including safety glasses, hearing protection, safety shoes, and gloves are recommended during assembly, installation, operation, maintenance, removal, or movement of the wire unroller.

STEP 6: Secure wire to the end post, and trim to length.

STEP 7: Loop remaining wire onto the frame cleats to prevent the wire from snagging while driving.

⚠ WARNING

Never transport the wire unroller on highways while connected to vehicle hitch.

⚠ WARNING

Before you operate the attachment, check over all pins, bolts, and connections to be sure all are securely in place. Replace any damaged or worn parts immediately.

STEP 1: Shut off the vehicle engine, set the parking brake, and remove the vehicle key.

STEP 2: Remove spool top plate retaining pin and top plate. Spool should be installed on frame spindle plate-side-down.

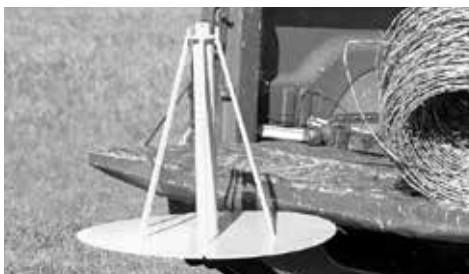

NOTE

If unspooling barbed wire, ensure the rubber brake pad is installed on spindle below spool. Remove rubber brake pad when unspooling Python-spooled smooth wire.

Operation

(continued)

⚠ WARNING

Safe operation of equipment requires the operator's full attention. Avoid distractions such as radio headphones, cell phones, etc. while operating.

⚠ DANGER

Do not allow riders on the equipment at any time. There is no safe place for any riders.

⚠ DANGER

Never place yourself between the vehicle and the attachment.

⚠ WARNING

Keep hands, feet, hair, jewelry, and clothing away from all moving and/or rotating parts.

STEP 3: Remove any tie wires from spooled wire. Orient spooled wire so the cone shape of the spool assembly fills the cone shape left in the wire by your Python Wire Winder, and set it gently down onto the spool. Place unroller top plate on spool, plate-side-down, aligning pin holes in top plate and spool assembly. Reinstall retaining pin.



⚠ DANGER

Before beginning operation, clear the work area of objects which might be picked up and thrown by or entangled in the wire and/or wire unroller.

STEP 4: Attach wire to starting post, and slowly drive forward to unroll wire.

⚠ DANGER

Never manually guide wire by hand or with tool.

⚠ CAUTION

Never exceed 10 MPH while unrolling wire.

Operation

(continued)

NOTE

Excessive speed while unrolling may cause the wire spool to over-spin and become tangled. Should that occur, come to a stop, back up slightly to relieve tension on the wire, and untangle the wire before continuing to unroll.

⚠ DANGER

Keep all helpers and bystanders twenty-five feet (25') away from the wire unroller or wire path before and during wire unroller rotation. The wire unroller must be positioned such that all winding operations, including the wire path, can be easily seen.

- STEP 5: Upon reaching the end post, wrap the wire around the cleats on the frame of the unroller. Slowly drive forward to put tension on the wire.



⚠ WARNING

Stay clear of wire path during tensioning. Wire may come loose or break, potentially injuring bystanders.

- STEP 6: Secure wire to the end post, and trim to length.
- STEP 7: Loop remaining wire onto the frame cleats to prevent the wire from snagging while driving.

Operation

Straightening Posts

⚠ DANGER

Never place yourself between the vehicle and the attachment.

⚠ WARNING

Personal protection equipment including safety glasses, hearing protection, safety shoes, and gloves are recommended during assembly, installation, operation, maintenance, removal, or movement of the wire unroller.

Removal & Storage

⚠ DANGER

Never allow anyone under the attachment at any time.

⚠ WARNING

Personal protection equipment including safety glasses, hearing protection, safety shoes, and gloves are recommended during assembly, installation, operation, maintenance, removal, or movement of the wire unroller.

The Python Wire Unroller has two slots for straightening posts: a circular slot for posts up to 5/8" diameter (rebar), and a T-post slot.

- STEP 1: Shut off the vehicle engine, set the parking brake, and remove the vehicle key.
- STEP 2: Insert post into the appropriate slot up to bent section. With moderate force, bend post back into shape.



⚠ WARNING

Never transport the wire unroller on highways while connected to vehicle hitch.

Before storage, the Python Wire Unroller should be thoroughly cleaned, washing off all dirt and grime. Always store the wire unroller in a dry, covered location.

- STEP 3: Separate the wire unroller from the vehicle, and lower it onto a flat, level surface in an area where children do not play. Securely block and support the wire unroller.
- STEP 4: Replace any damaged or missing safety signs.

Troubleshooting

Problem	Possible Cause	Solution
Python Wire Winder-spoiled wire unspooling erratically	Wire wound too loosely	Wind wire more tightly. Refer to <i>Python Wire Winder Operator's Manual</i> .
Wire pulling tightly around spool while unspooling	Rubber brake pad not needed for unspooling smooth wire	Remove rubber brake pad.
Wire tangling/seizing while unspooling	Rubber brake pad missing	Ensure the rubber brake pad is installed.
	Rubber brake pad worn	Replace rubber brake pad.
	Wire spool over-spinning	Drive at a slower speed.

Rubber Brake Pad Usage

Typically, rubber brake pad usage is as follows. If you are having difficulty unrolling wire, try installing or removing the rubber brake pad.

Use Rubber Brake Pad?	Smooth Wire	Barbed Wire
New Wire	Yes	Yes
Python-spoiled wire	No	Yes

For additional assistance, please call your dealer or contact Danuser direct:

*Tel: (573) 642-2246
E-mail: sales@danuser.com*

Maintenance

WARNING

Personal protection equipment including safety glasses, hearing protection, safety shoes, and gloves are recommended during assembly, installation, operation, maintenance, removal, or movement of the wire unroller.

Proper maintenance is key to the long life of the wire unroller. Careful inspection and routine maintenance help avoid costly downtime and repair. Do not use the Python Wire Unroller with any damaged parts.

DANGER

Never replace the retaining bolt and/or spool retention pin with anything other than one that meets the original equipment manufacturer's standards and requirements. A longer, or protruding, fastener is more likely to grab clothing or gloves, which can result in serious injury or death.

WARNING

Do not modify the wire unroller. Modifications may weaken the integrity of the wire unroller and may impair the safety, function, life, and performance of the wire unroller.

Maintenance	Interval
Inspect the attachment for any damage or worn parts. Repair or replace as necessary.	Before each use
Check for damaged or missing safety signs. Replace as necessary.	Before each use
Visually inspect all welds for cracks. Check all bolts and fasteners for tightness.	Before each use
Inspect upper and lower spool plates for damage. Inspect lower assembly for bending.	Before each use

This product can expose you to chemicals including lead, which are known to the State of California to cause cancer and birth defects or other reproductive harm. For more information go to www.P65Warnings.ca.gov.ca.gov/product.

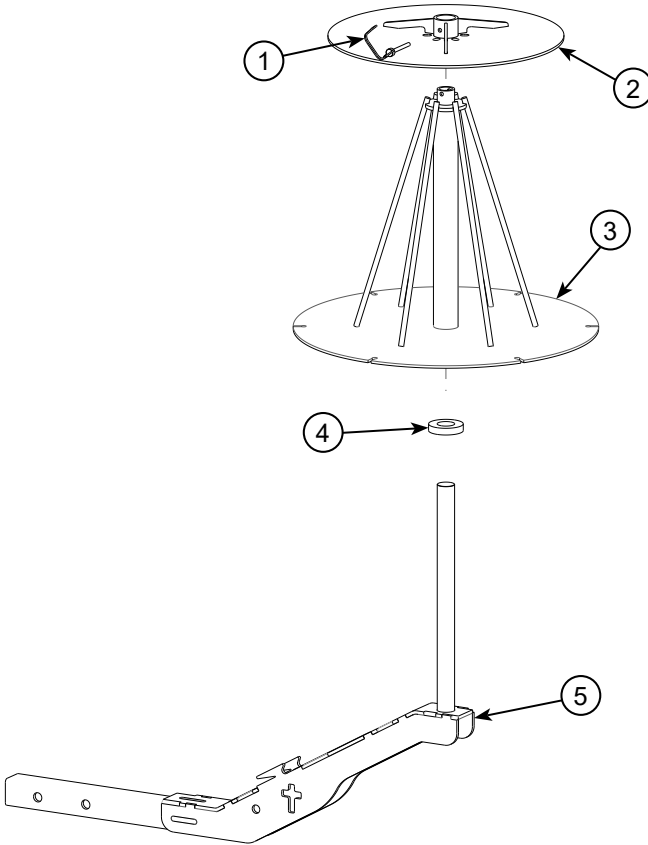

REF. NO.	PART NO.	DESCRIPTION	QTY.
1	20012	Retaining Pin	1
2	180609	Top Plate Assembly	1
3	180608	Spool Assembly	1
4	180622	Rubber Brake Pad	1
5	180607	Frame Assembly	1

Python Wire Winder

Python Wire Winder

PN 170610 - The Python Wire Winder connects onto a hydraulic auger drive unit with 2" hex shaft, and can wind up to 6 miles of smooth or 3/4 mile of barbed wire into convenient rolls.

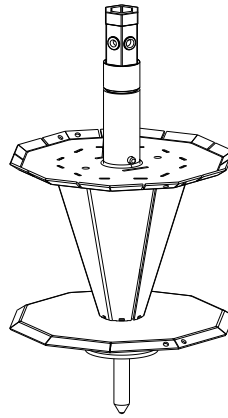

Warranty

DANUSER LIMITED WARRANTY

Danuser Machine Company, LLC (“Danuser”) warrants its products, under normal use and maintenance, to be free from defects in material and workmanship for period(s) specified below from the purchase date from an authorized Danuser Dealer. Start of the warranty period is determined by purchase date. Proof of purchase may be required. This Limited Warranty is extended only to the original purchaser of Danuser products.

Python Wire Unroller - 1 Year
Wear Items Not Covered Under Warranty - Rubber Brake Pad

1. During the applicable warranty period, Danuser, at its option, will repair or replace any part determined by Danuser to be defective. Such repair or replacement shall take place at Danuser’s factory, or a location designated by Danuser. Under no circumstances shall Danuser be obligated for the cost of any repair or replacement by anyone other than Danuser without its express written consent.
2. Parts may not be returned without written authorization from Danuser.
3. Some purchased components, including but not limited to hydraulic components, are subject to the inspection and warranty of the respective manufacturer. Thus, delays in a warranty determination can be expected while Danuser awaits their decision.
4. This warranty is void if any attempt is made to make field repairs to hydraulic components. To qualify for warranty inspection, the “failed” part(s) must be returned in its original “failed” condition.
5. To make a claim under this warranty, you may either contact your authorized Danuser Dealer or initiate a claim directly with Danuser. In either case, a Warranty Claim Form must be completed and written authorization from Danuser obtained prior to returning parts. All warranty claims must include detailed information regarding make and model of vehicle on which the Danuser product was mounted, hours of use, description of events that led up to the failure, and any other information helpful in reviewing the warranty claim. All warranty returns must be prepaid. Shipments arriving at our factory on a freight collect basis will be refused by our receiving department. The freight charge will be credited if the parts are determined by Danuser to be defective, and the associated freight costs in returning those parts will be prepaid by Danuser. **NOTE:** Hydraulic components must arrive with all ports sealed from dirt and moisture. If a hydraulic component arrives with open ports, the warranty is void and no inspection will be made.
6. Products or parts thereof which, as determined by Danuser’s examination, show wear from normal use, have been improperly operated, damaged by accident or negligence, field repaired, altered or modified are not considered defective in material and workmanship and are not covered by this warranty. This warranty does not apply to parts subject to normal wear (“Wear Items”) or to damage caused by the failure to perform recommended maintenance or to replace worn parts. This warranty shall not obligate Danuser to bear any cost of labor for field repair, replacement, testing, or adjustment nor for damage caused by accident, abuse, misuse, or environmental elements.
7. Any parts or labor required to repair or replace parts not covered under this warranty will be charged to the customer. Parts repaired or replaced by Danuser are then covered by this warranty only for the remainder of the original warranty as if such parts were original parts.
8. Danuser reserves the right to change its specifications and designs at any time.

This warranty is exclusive and in lieu of all other express warranties, if any, including the implied warranties of merchantability and fitness for a particular purpose. It shall not extend beyond the duration of the expressed warranty provided herein and the remedy for violations of any implied warranty shall be limited to repair or replacement of the defective part pursuant to the terms contained herein. No employee, dealer, salesman, or representative is authorized to change this warranty in any way or grant any other warranty. Danuser shall not be liable for any consequential, incidental, or punitive damages, losses, or expenses, including those resulting from or caused by any defects.

Danuser Machine Company, LLC
500 E. 3rd St
P.O. Box 368
Fulton, MO 65251

Tel: (573) 642-2246
E-mail: sales@danuser.com
Website: www.danuser.com