

MEGA MIXER

S75

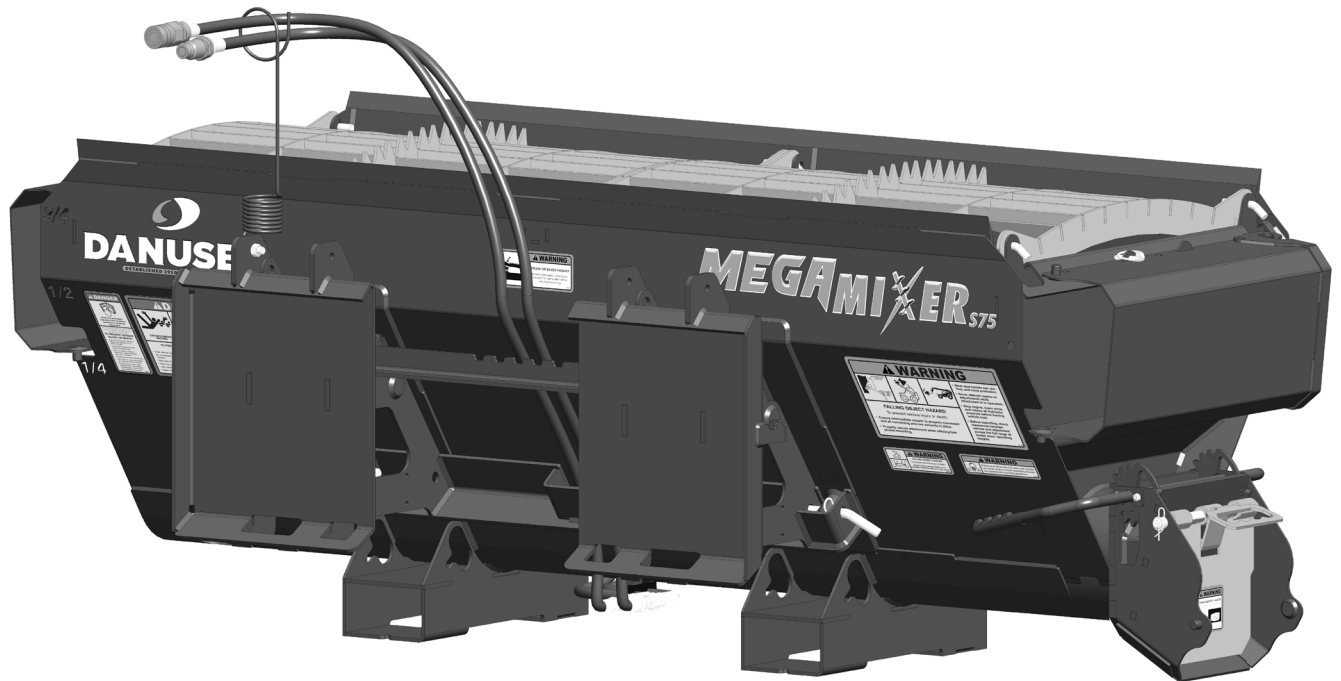

! Read this entire manual. This safety alert symbol is used throughout this manual to call your attention to messages involving your personal safety and the safety of others. Failure to follow these instructions can result in injury or death.

! WARNING

Si no entiende ingles, se prefiere que busque a alguien que interprete las instrucciones para usted.

Owner: _____
Date Purchased: _____
Model #: _____ Serial #: _____
Manual #: _____ 9MMEGA2461194

Operator's Manual

Danuser Machine Company, LLC
500 E. 3rd St.
P.O. Box 368
Fulton, MO 65251
Tel: (573) 642-2246
E-mail: sales@danuser.com
Website: www.danuser.com



Dear Owner/Operator,

Thank you for purchasing this Danuser Mega Mixer. We appreciate your business.

With a 3/4 yard capacity, the Mega Mixer is designed to mix concrete or scoop material from a pile, then transport and dispense the concrete or material where it is needed.

Your safety as an operator of our product is very important to us. Therefore, *before* you assemble, install, operate, maintain, service, remove, or move your Danuser Mega Mixer, read and understand this manual thoroughly. If there is anything you do not understand, immediately contact your dealer, or contact our factory direct.

Tel: (573) 642-2246
E-mail: sales@danuser.com

Your satisfaction in the performance and longevity of our product is also very important to us and can be prolonged by proper assembly, installation, operation, and maintenance as instructed in this manual.

Thank you again for your business and for your trust in our product. Please feel free to contact us at any time for further assistance.

Sincerely,

Danuser Machine Company, LLC
500 E. 3rd St.
P.O. Box 368
Fulton, MO 65251

Tel: (573) 642-2246
E-mail: sales@danuser.com Website: www.danuser.com

Danuser provides this manual "as is" without warranty of any kind, either expressed or implied. Danuser assumes no responsibility for errors or omissions. Danuser assumes no liability for damages resulting from the use of the information contained herein. Danuser reserves the right to revise and improve its products as it sees fit. This manual describes the state of this product at the time of its publication and may not reflect the product in the future.

Danuser is a registered trademark.

Foreword

Please read this manual thoroughly!

Before you assemble, install, operate, maintain, service, remove, or move your Danuser Mega Mixer, read this manual thoroughly. If there is anything you do not understand, immediately contact your dealer, or call our factory direct at (573) 642-2246. Powered equipment can be dangerous if not assembled, installed, operated, maintained, serviced, removed, or moved properly.

Warranty Registration

To activate your warranty coverage and to provide you with efficient customer service, please fill out your WARRANTY REGISTRATION FORM. This form is included in your unit's paperwork package. If you did not complete a WARRANTY REGISTRATION FORM or did not receive one, please call Danuser. Or, register online at www.danuser.com. Your satisfaction with our product and your safety as a user of our product are both very important to us.

Symbols

 This SAFETY ALERT symbol identifies important safety messages. Carefully read each safety message that follows. Failure to understand and obey a safety message, or recognize a safety hazard, could result in injury or death to you or others around you. The operator is ultimately responsible for the safety of himself, as well as others, in the operating area of the Mega Mixer.





<i>Symbol</i>	<i>Meaning</i>
	Indicates an imminently hazardous situation which, if not avoided, will result in death or serious injury.
	Indicates a potentially hazardous situation which, if not avoided, could result in death or serious injury, including hazards that are exposed when guards are removed.
	Indicates a potentially hazardous situation which, if not avoided, may result in minor or moderate injury. It may also be used to alert against unsafe practices.
	This is important information for proper use of this equipment. Failure to comply may lead to premature equipment failure.

Table of Contents

	Page
Letter to Owner/Operator	2
Foreword	3
Symbols	3
Safety	4
Decals & Safety Signs	7
Specifications	9
Hydraulic Requirements	11
Assembly & Installation	12
Operation	19
Cleaning	24
Removal & Storage	25
Troubleshooting	26
Maintenance & Lubrication	28
Service	29
Torque Values Chart	31
Parts	32
Accessories	42
Warranty	5060

WARNING

Working with unfamiliar equipment can lead to careless injuries. Read and understand this manual and the manual for your vehicle before assembling, installing, operating, maintaining, servicing, removing, or moving this Danuser Mega Mixer. If there is anything in this manual you do not understand, contact your dealer or Danuser. The safe use of this attachment is strictly up to you, the operator. If this attachment is used, loaned, or rented by any other person, it is the owner's responsibility to make certain that the operator prior to operating:

- Reads and understands the Operator's Manual
 - Is instructed in safe and proper use
- The Mega Mixer is designed to be operated from the vehicle seat. Keep bystanders away from the work area. Do not operate with another person in contact with the Mega Mixer.
 - All operators of this attachment must read and understand this entire manual, paying particular attention to safety messages and operation instructions, prior to assembling, installing, operating, maintaining, servicing, removing, or moving the Mega Mixer.
 - Please remember it is also important that you read, understand, and follow the safety signs on the attachment. Clean or replace all safety signs if they cannot be clearly read and understood. They are there for your safety as well as the safety of others. Danuser will furnish new safety signs upon request at no charge.
 - All things with moving parts are potentially hazardous. There is no substitute for a cautious, safe-minded operator who recognizes potential hazards and follows reasonable safety practices.
 - Personal protection equipment including hard hat, safety glasses, safety shoes, gloves, and hearing protection are recommended during assembly, installation, operation, maintenance, service, removal, or movement of the attachment.
 - Exposure to silica dust and other dust hazards can cause serious or fatal respiratory disease. Use appropriate respiratory protection.
 - When the use of hand tools is required to perform any part of assembly, installation, operation, maintenance, or service of the attachment, be sure the tools used are designed and recommended by the tool manufacturer for that specific task.
 - Never check pressurized system for leaks with your bare hand. Wear proper hand and eye protection and use wood or cardboard when searching for suspected leaks. Oil escaping from pinhole leaks under pressure can penetrate skin and create a serious medical emergency. If any fluid is injected into the skin, gangrene, blood poisoning, even death may result. Obtain medical attention immediately.
 - Always use two people to handle heavy, unwieldy components during assembly, installation, maintenance, service, removal, or movement of the attachment.
 - Never place any part of your body where it would be in danger if movement should occur during assembly, installation, operation, maintenance, service, removal, or movement of the Mega Mixer.
 - Only properly trained people should operate this equipment. Do not allow anyone who has not read this entire manual and understands the safety rules, safety signs, and operation instructions to use this attachment.
 - Never allow children to operate or be around the Mega Mixer.
 - Do not use the Mega Mixer as a work platform.
 - Do not allow riders on the equipment at any time. There is no safe place for any riders.

Safety

(continued)

- Never use alcoholic beverages or drugs which can hinder alertness or coordination while operating this equipment. Consult your doctor about operating this equipment while taking prescription or over-the-counter medications.
- Safe operation of equipment requires the operator's full attention. Avoid distractions such as radio headphones, cell phones, etc. while operating.
- Stay away from power lines when transporting, raising, or operating the attachment. Electrocutation can occur without direct contact.
- The Mega Mixer must be securely latched to the vehicle. Ensure both locking handles are in the locked position with pins fully seated. Ensure intermediate coupler is properly connected and all connecting pins are securely in place. Properly secure the Mega Mixer when utilizing fork pocket mounting. An improperly latched Mega Mixer can fall without warning.
- Make sure all guards and safety grates are in place and secured before operating equipment.
- Keep hands, feet, hair, jewelry, and clothing away from all moving and/or rotating parts.
- Never place yourself between the vehicle and the attachment.
- Never allow anyone under the attachment at any time.
- Never reach into discharge end of auger.
- Keep clear of auger while in operation. Never position the material by hand or with any tool when the auger is rotating.
- Do not exceed the vehicle's rated operating load. Use sufficient counterweights. Move the vehicle slowly when the attachment is raised.
- Carry the load low. A heavy load can cause instability of the vehicle. Use extreme care during travel. Slow down on turns and watch out for bumps. Use all safety devices, including a seat belt, as recommended in the vehicle operator's manual.
- For operator safety, always keep the load in front of the vehicle. Load should never be tilted toward or positioned over the operator.
- Do not operate the Mega Mixer on steep hillsides. When operating the Mega Mixer on uneven or hilly terrain, position the vehicle with the attachment uphill. With the attachment downhill, the vehicle could tip when attempting to raise the Mega Mixer. Consult your vehicle operator's manual for maximum incline allowable.
- Always shut off the vehicle engine, remove the key, lower vehicle arms, and relieve all hydraulic pressure before dismounting the vehicle. Never leave equipment unattended with the vehicle running.
- Never attempt adjustments, service, or repairs while the equipment is in operation.
- Never work under equipment supported by hydraulics. Even with the vehicle shut off, equipment can suddenly drop if controls are actuated or if hydraulic lines burst.
- Before disconnecting hydraulic lines or fittings, be sure to relieve all pressure by cycling all hydraulic controls after shutdown. Remember hydraulic systems are under pressure whenever the engine is running and may hold pressure after shutdown.
- Store the attachment on a flat, level surface where children do not play. Securely block and support the attachment.
- Do not modify the attachment. Modifications can weaken the integrity of the attachment and may impair the safety, function, life, and performance of the Mega Mixer.

Safety

(continued)

- When making repairs or servicing the Mega Mixer, use only parts that meet the original equipment manufacturer's standards and requirements.
- Always use care when operating the Mega Mixer. Most accidents occur because of neglect or carelessness.

Safety is a primary concern in the design, manufacture, sale, and use of the Mega Mixer. Danuser confirms to you, our customer, our concern for safety.

DANGER

Improper operation of this Mega Mixer can cause serious personal injury or death. Operation of this attachment should only be done by a competent adult acting in compliance with the Operator's Manual. Since Mega Mixer operations are beyond our control, we disclaim all liability for any damages, injuries, or death which may result.

WARNING

This product can expose you to chemicals known to the State of California to cause cancer and birth defects or other reproductive harm. For more information go to www.P65Warnings.ca.gov/product.

Decals & Safety Signs

The Mega Mixer comes equipped with all safety signs in place. Their locations are shown in this section. Read and follow their instructions and ensure their care:

- Keep safety signs clean and legible at all times.
- Replace safety signs that are missing, illegible, or damaged.
- Ensure replacement parts installed during repair have safety signs attached.

To install new safety signs, follow these steps:

1. Clean the area where the safety sign is to be placed.
2. Spray a little soapy water on the surface where the safety sign is to be placed.
3. Peel the backing from the safety sign and apply it in the position shown.
4. Firmly press the safety sign and squeeze out the air bubbles with a straight edge (e.g., a credit card).

PART NO. DANUSER109

Locations: Hopper, both sides



PART NO. 170130

Locations: Hopper, both sides



PART NO. CA65

Location: Hopper, motor end



Model No. & Serial No.

Location: Hopper, motor end

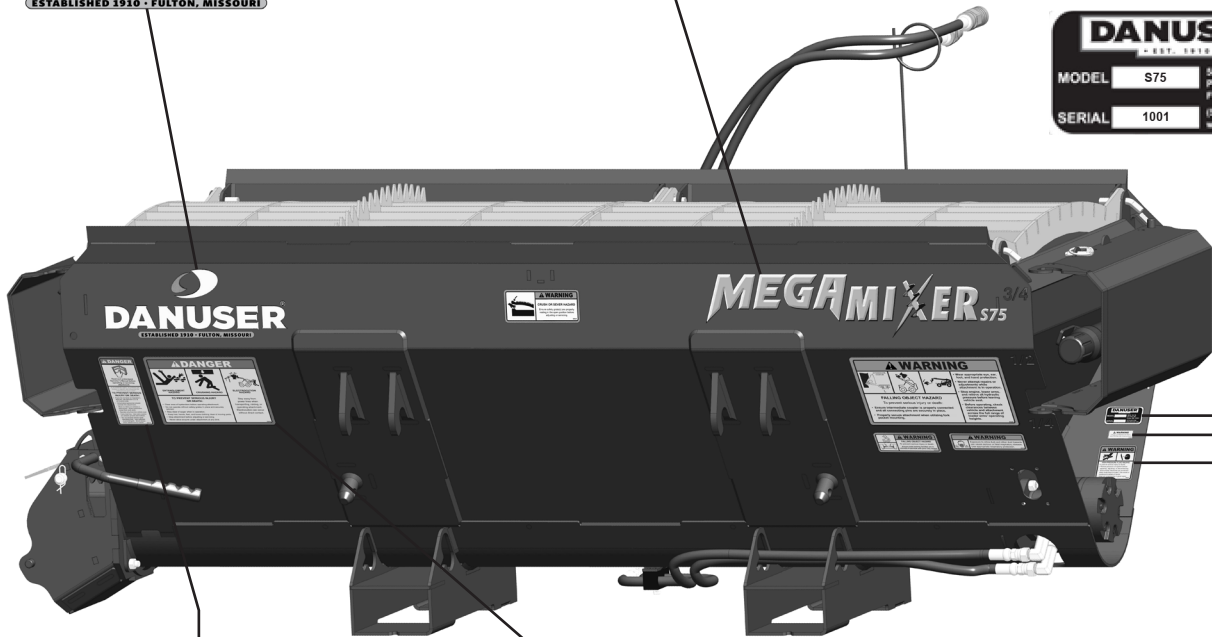
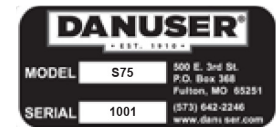

PART NO. DIG13

Locations: Hopper, both sides



PART NO. DIG46

Locations: Hopper, both sides



PART NO. DIG5

Location: Hopper, motor end



WARNING

Clean or replace all safety signs if they cannot be clearly read and understood.

Decals & Safety Signs

(continued)

PART NO. DIG47

Locations: Hopper, both sides

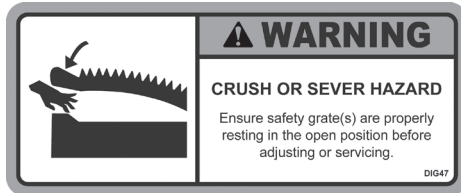

PART NO. 170133

Locations: Hopper, both sides

S75

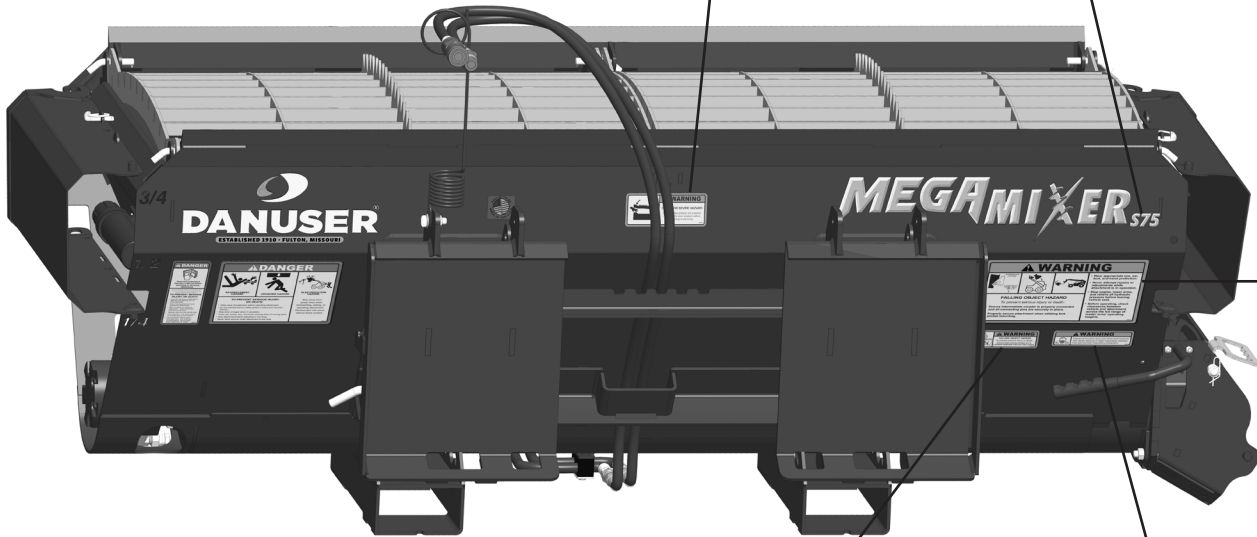

PART NO. DIG34

Location:
Discharge flap



PART NO. DIG52

Location:
Discharge flap



PART NO. DIG35

Locations: Hopper, both sides

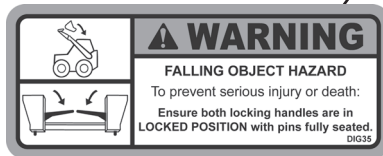

PART NO. DIG30

Locations: Hopper, both sides

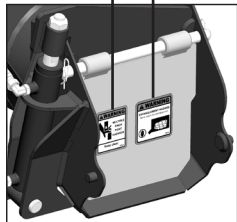

Hydraulic Gate

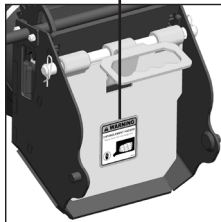

Manual Gate

PART NO. DIG49

Locations: Hopper, both sides

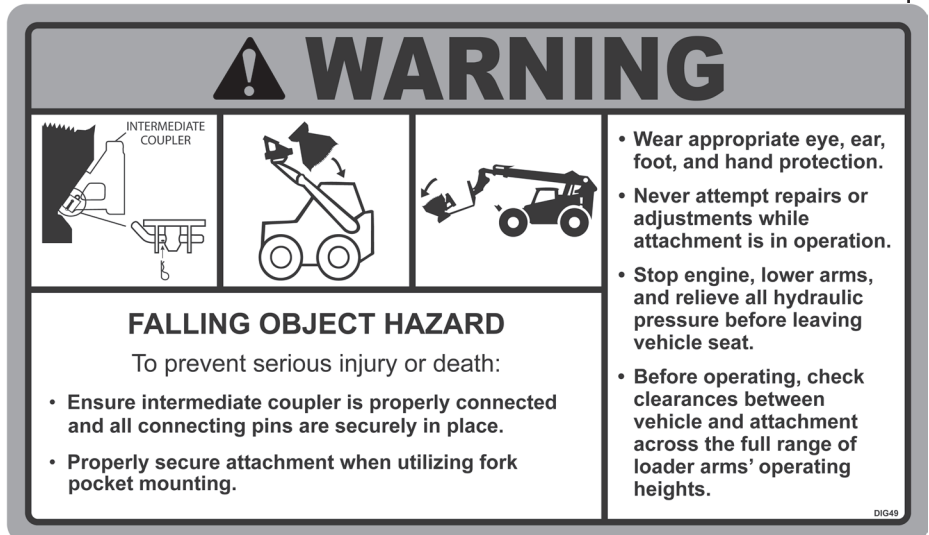

WARNING

Clean or replace all safety signs if they cannot be clearly read and understood.

Specifications

Manual Gate

Operator's Manual
Direction Terminology

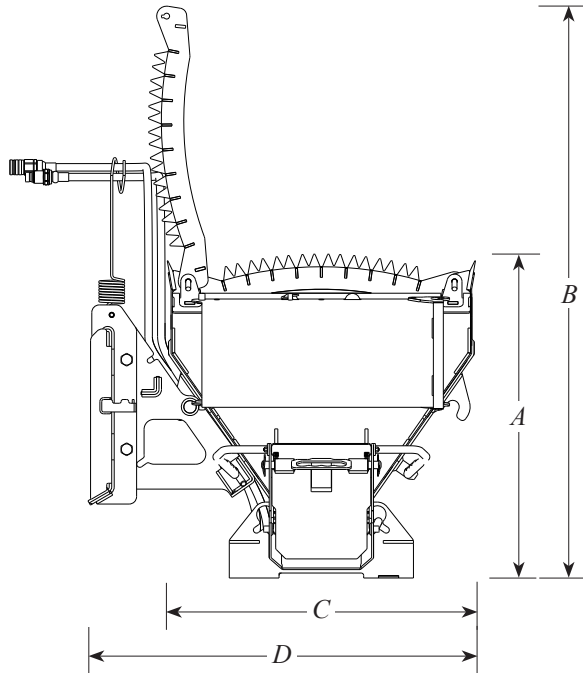
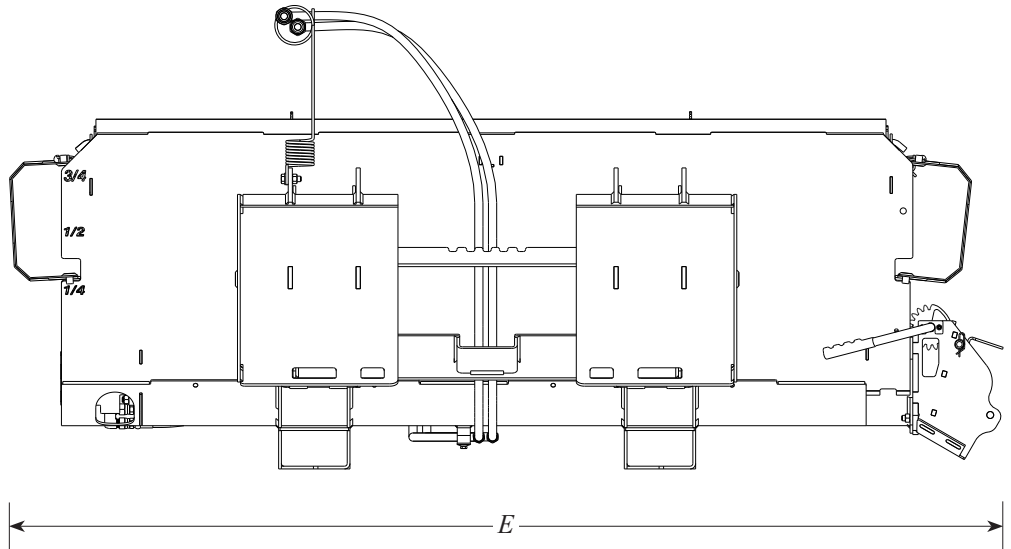
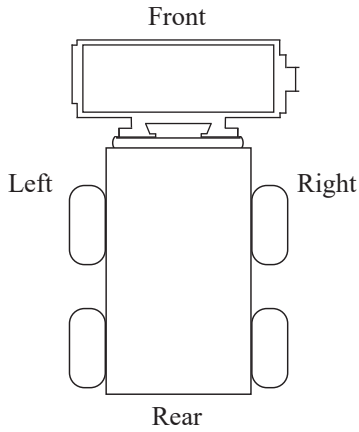

Mega Mixer S75 can mix and discharge...	
Concrete (up to 1" Slump)	Clean Rock (up to 1")
Mortar	Dry Topsoil
Grout	Sawdust
Feed	Compost
Wet Sand	Manure
Dry Sand	Asphalt

Mega Mixer S75 - Manual Gate	
Height, Grates Lowered (A)	32"
Height, Grates Raised (B)	57.25"
Hopper Width (C)	31"
Overall Width (D)	38.75"
Overall Length (E)	93.75"
Weight	805 lb.
Auger Diameter	8"
Center Column Diameter	2.38" O.D. 0.22" wall
Auger Length	70"
Flighting Spacing	8"
Capacity	3/4 yard (20 ft ³) Up to 1 yard (27 ft ³) with optional hopper extension
80-lb. Bags Concrete Mix	Approx. 25 (3/4 yd) Approx. 35 (1 yd)
Dispense Rate	26 seconds @ 25 GPM
Hydraulic Requirements	Up to 25 GPM Up to 3,500 PSI
Mounting Options	Skid-Steer Quick Attach Pallet Forks

Specifications

Hydraulic Gate

Operator's Manual
Direction Terminology

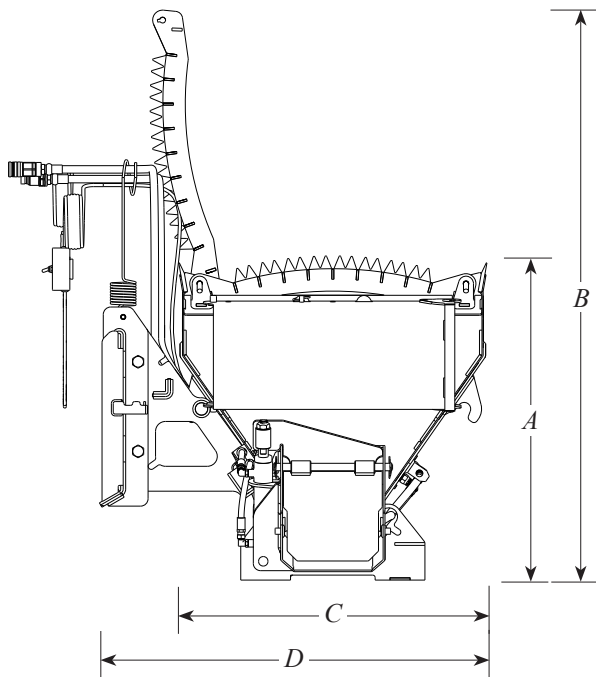
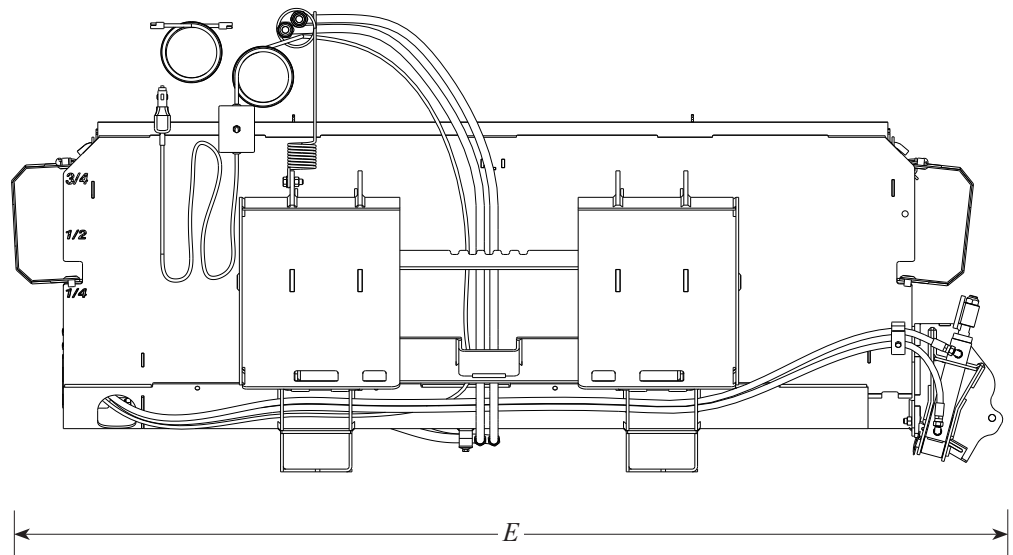
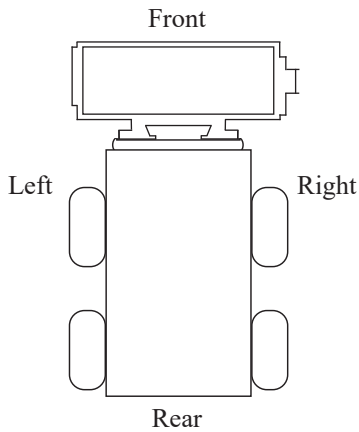

Mega Mixer S75 can mix and discharge...	
Concrete (up to 1" Slump)	Clean Rock (up to 1")
Mortar	Dry Topsoil
Grout	Sawdust
Feed	Compost
Wet Sand	Manure
Dry Sand	Asphalt

Mega Mixer S75 - Hydraulic Gate	
Height, Grates Lowered (A)	32"
Height, Grates Raised (B)	57.25"
Hopper Width (C)	31"
Overall Width (D)	38.75"
Overall Length (E)	93.75"
Weight	960 lb.
Auger Diameter	8"
Center Column Diameter	2.38" O.D. 0.22" wall
Auger Length	70"
Flighting Spacing	8"
Capacity	3/4 yard (20 ft ³) Up to 1 yard (27 ft ³) with optional hopper extension
80-lb. Bags Concrete Mix	Approx. 25 (3/4 yd) Approx. 35 (1 yd)
Dispense Rate	26 seconds @ 25 GPM
Hydraulic Requirements	Up to 25 GPM Up to 3,500 PSI
Mounting Options	Skid-Steer Quick Attach Pallet Forks

Hydraulic Requirements

Filtration Requirements:

- A filter of, at least, 10 micron filtration is required.

NOTE

The life of the hydraulic componentry is almost entirely dependent upon cleanliness of the oil. Instructions in your vehicle operator's manual regarding filter and oil changes should be carefully followed. Even small amounts of dirt in the hydraulic oil can cause premature hydraulic componentry failure that is not covered by warranty.

Pressure and Flow Requirements:

- The Mega Mixer is designed to operate up to 25 GPM and up to 3,500 PSI.

Hydraulic Fluid Selection Requirements:

- Premium grade petroleum based fluids will provide the best performance.
- Fluids that contain anti-wear agents, rust inhibitors, anti-foaming agents, and oxidation inhibitors are recommended.
- The viscosity of the fluid should never fall below 70 SUS (13 cST). The best viscosity range for the Mega Mixer is 100-200 SUS (20-43 cST).

Assembly & Installation

⚠️ WARNING

Personal protection equipment including hard hat, safety glasses, safety shoes, gloves, and hearing protection are recommended during assembly, installation, operation, maintenance, service, removal, or movement of the attachment.

⚠️ CAUTION

Always use two people to handle heavy, unwieldy components during assembly, installation, maintenance, service, removal, or movement of the attachment.

Prepare the Vehicle

Read and understand the manual for your vehicle before assembling or installing the Mega Mixer. The vehicle must be equipped with auxiliary hydraulics and either a skid-steer quick attach hitch or pallet forks. The use of the Mega Mixer may require the addition of counterweights to ensure the combined weight of the attachment and load does not exceed the rated capacity of your vehicle.

⚠️ WARNING

Do not exceed the vehicle's rated operating load. If necessary, use sufficient counterweights.

Recommended Tools

- 3/4" wrench (2)
- 9/16" wrench
- Box cutter/metal snips

STEP 1: Remove the bolts securing the Mega Mixer to the pallet, banding, and any other packaging materials. Set aside safety grates. Remove chutes and hang on hopper sides, securing with klik pins.

STEP 2: Place the safety grates atop the hopper with the bottom of each safety grate resting on the support and the bag breaker facing upwards. Once both safety grates are in place, insert the six hinge pins into the safety grates, and turn each downward to secure.

⚠️ DANGER

Do not operate Mega Mixer without safety grates in place and securely latched.

STEP 3: Using two 3/4" wrenches, attach the hose retention spring to the side of the Mega Mixer closest to the hydraulic connections on your vehicle (i.e., the left side on most skid-steers and compact track loaders). Tighten the nut to the torque specified in the *Torque Values Chart*.

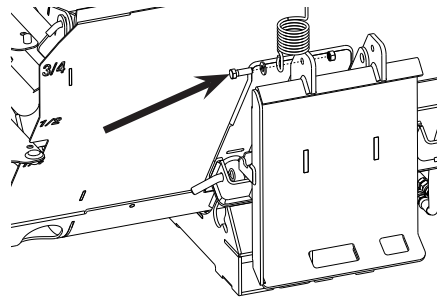

STEP 4: Route the hydraulic hoses through the hose retention spring.

Assembly & Installation

(continued)

- STEP 5: Ensure the intermediate mount is properly connected. The rods on the intermediate mount should be fully engaged in the hopper hooks with connecting pins and hair pin cotters in place.

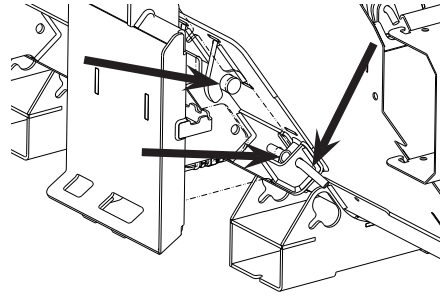

- STEP 6: Park the vehicle on level ground and install the Mega Mixer by following your vehicle operator's manual for installing an attachment.

⚠ WARNING

The Mega Mixer must be securely latched to the vehicle. Ensure both locking handles are in the locked position with pins fully seated. Ensure intermediate coupler is properly connected and all connecting pins are securely in place. Properly secure the Mega Mixer when utilizing fork pocket mounting. An improperly latched Mega Mixer can fall without warning.

- STEP 7: Ensure there is sufficient clearance between the Mega Mixer and the vehicle. Ensure vehicle cab door, if equipped, can be opened freely. If necessary, refer to *Intermediate Mount Adjustment*.
- STEP 8: Connect the hydraulic hoses to the vehicle's auxiliary hydraulics. Test the vehicle to make sure you have enough hose length to perform the full range of the loader arms' operating heights.

⚠ WARNING

Before connecting or disconnecting hydraulic lines or fittings, be sure to relieve all pressure by cycling all hydraulic controls after shutdown. Remember hydraulic systems are under pressure whenever the engine is running and may hold pressure after shutdown.

NOTE Ensure quick couplers are clean prior to connection.

NOTE Hose routing is the responsibility of the operator. Pinched and/or stretched hoses are not covered under the warranty.

If the Mega Mixer is equipped with the hydraulic gate, follow Steps 9-11. If not, skip to Step 12.

- STEP 9: Ensure the wiring harness is connected to the diverter valve and route the wires along the hydraulic hoses to the vehicle. Secure wires with zip-ties.

Assembly & Installation

(continued)

⚠ WARNING

Keep hands, feet, hair, jewelry, and clothing away from all moving and/or rotating parts.

Assembly & Installation

Changing Dispensing Side
(Skid-Steer Mount)

⚠ WARNING

Personal protection equipment including hard hat, safety glasses, safety shoes, gloves, and hearing protection are recommended during assembly, installation, operation, maintenance, service, removal, or movement of the attachment.

STEP 10: Route the control portion of the wiring harness along the loader arm of the vehicle and into the cab. Secure wires with zip-ties. Mount the switch out of the way of other controls.

NOTE Keep wiring a safe distance from hot components such as heater or exhaust.

STEP 11: Connect the wiring harness to a 12-volt auxiliary power outlet. If necessary, consult your dealer.

STEP 12: Engage the vehicle's auxiliary hydraulics to make sure the Mega Mixer auger freely rotates forward and reverse.

STEP 13: Check the hydraulic system for leaks.

⚠ WARNING

Never check pressurized system for leaks with your bare hand. Wear proper hand and eye protection and use wood or cardboard when searching for suspected leaks. Oil escaping from pinhole leaks under pressure can penetrate skin and create a serious medical emergency. If any fluid is injected into the skin, gangrene, blood poisoning, even death may result. Obtain medical attention immediately.

The Mega Mixer may be configured to dispense material from the left or right side.

STEP 1: Park the vehicle on level ground, and rest the Mega Mixer on a solid, level surface.

STEP 2: Shut off the vehicle and relieve all hydraulic pressure.

STEP 3: Disconnect hydraulic hoses and wires (if equipped with hydraulic gate) and drape them over the center of the hopper.

⚠ WARNING

Before connecting or disconnecting hydraulic lines or fittings, be sure to relieve all pressure by cycling all hydraulic controls after shutdown. Remember hydraulic systems are under pressure whenever the engine is running and may hold pressure after shutdown.

STEP 4: With Mega Mixer mounted to vehicle, remove hair pin cotters, and remove connecting pins.

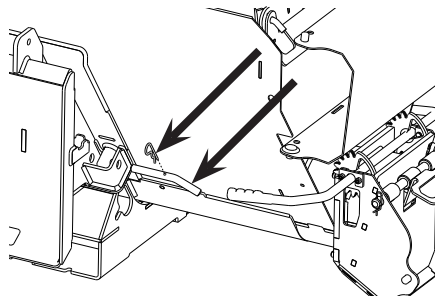

Assembly & Installation

(continued)

STEP 5: Turn on the vehicle. Tilt the intermediate mount slightly forward, and lower to disengage the hooks. Slowly back the vehicle away with the intermediate mount attached to the vehicle.

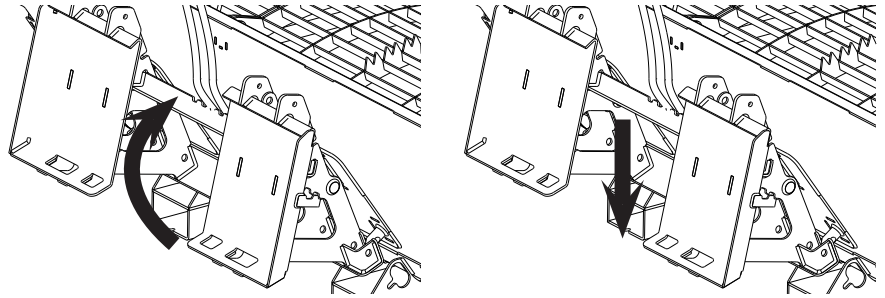

STEP 6: Once the intermediate mount has been removed from the hopper, reposition the hydraulic hoses and wires (if equipped with the hydraulic gate) underneath the hopper to the other side, and drape hoses and wires over center of the hopper between the two sets of hooks.

STEP 7: Carefully reposition the vehicle to the intended side of the Mega Mixer. Line the hooks up between the vertical uprights of the intermediate mount. Ensure the hoses are against the hopper and located through the designated hose routing space in the intermediate mount.

NOTE

When changing sides, take care to route the hoses and wires to avoid pinching. Pinched and/or stretched hoses and wires are not covered under warranty.

STEP 8: Raise the intermediate mount, engaging the intermediate rods fully into the hopper hooks. Tilt the intermediate mount back until the lower portion comes into contact with side of hopper.

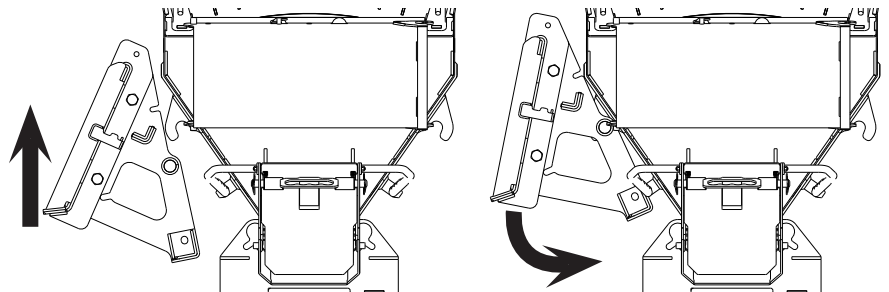

Assembly & Installation

(continued)

STEP 9: Shut off the vehicle. Reinstall both connecting pins and hair pin cotters.

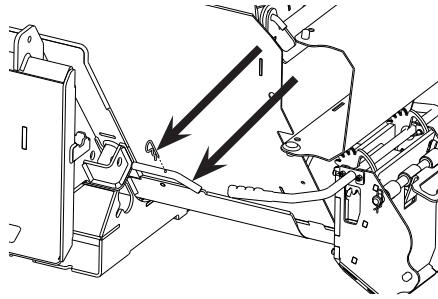

⚠ WARNING

The Mega Mixer must be securely latched to the vehicle. Ensure both locking handles are in the locked position with pins fully seated. Ensure intermediate mount is properly connected and all connecting pins are securely in place. Properly secure the Mega Mixer when utilizing fork pocket mounting. An improperly latched Mega Mixer can fall without warning.

STEP 10: Route the hydraulic hoses and wires (if equipped with the hydraulic gate) through the hose retention spring.

STEP 11: Reconnect hydraulic hoses and wires (if equipped with the hydraulic gate) and engage the vehicle's auxiliary hydraulics to make sure the Mega Mixer auger freely rotates forward and reverse.

STEP 12: Check the hydraulic system for leaks.

⚠ WARNING

Never check pressurized system for leaks with your bare hand. Wear proper hand and eye protection and use wood or cardboard when searching for suspected leaks. Oil escaping from pinhole leaks under pressure can penetrate skin and create a serious medical emergency. If any fluid is injected into the skin, gangrene, blood poisoning, even death may result. Obtain medical attention immediately.

⚠ WARNING

Keep hands, feet, hair, jewelry, and clothing away from all moving and/or rotating parts.

Assembly & Installation

Intermediate Mount Adjustment

! WARNING

Personal protection equipment including hard hat, safety glasses, safety shoes, gloves, and hearing protection are recommended during assembly, installation, operation, maintenance, service, removal, or movement of the attachment.

! CAUTION

Always use two people to handle heavy, unwieldy components during assembly, installation, maintenance, service, removal, or movement of the attachment.

The intermediate mount may be raised or lowered to allow the Mega Mixer to sit higher or lower relative to the vehicle.

Recommended Tools

- 1-1/8" wrench (2)
- Torque wrench

STEP 1: Park the vehicle on level ground, and rest the Mega Mixer on a solid, level surface.

STEP 2: Disconnect hydraulic hoses and wires (if equipped with hydraulic gate) and drape them over the center of the hopper.

! WARNING

Before connecting or disconnecting hydraulic lines or fittings, be sure to relieve all pressure by cycling all hydraulic controls after shutdown. Remember hydraulic systems are under pressure whenever the engine is running and may hold pressure after shutdown.

STEP 3: Follow your vehicle operator's manual for removing an attachment.

STEP 4: Using two 1-1/8" wrenches, remove the eight 3/4" bolts and nuts from the intermediate mount.

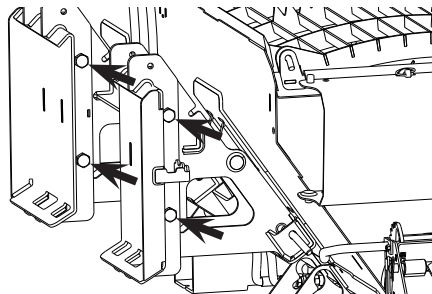

STEP 5: Relocate the connection plates to the desired position, using one bolt in each side to hold plate position.

NOTE

Raising the intermediate mount will lower the resting position of the Mega Mixer relative to the vehicle. Lowering the intermediate mount will raise the resting position of the Mega Mixer relative to the vehicle.

STEP 6: Install the remaining 3/4" bolts. Tighten the nuts to the torque specified in the *Torque Values Chart*.

STEP 7: Ensure the skid-steer quick attach mount brackets are installed at the same relative height.

STEP 8: Park the vehicle on level ground and install the Mega Mixer by following your vehicle operator's manual for installing an attachment.

Assembly & Installation

(continued)

Assembly & Installation

Hopper Extension

⚠ WARNING

Personal protection equipment including hard hat, safety glasses, safety shoes, gloves, and hearing protection are recommended during assembly, installation, operation, maintenance, service, removal, or movement of the attachment.

⚠ CAUTION

Always use two people to handle heavy, unwieldy components during assembly, installation, maintenance, service, removal, or movement of the attachment.

STEP 9: Reconnect the hydraulic hoses and wires (if equipped with the hydraulic gate) and check for leaks.

⚠ WARNING

Never check pressurized system for leaks with your bare hand. Wear proper hand and eye protection and use wood or cardboard when searching for suspected leaks. Oil escaping from pinhole leaks under pressure can penetrate skin and create a serious medical emergency. If any fluid is injected into the skin, gangrene, blood poisoning, even death may result. Obtain medical attention immediately

Recommended Tools

- Dead-blow hammer or mallet

STEP 1: Park the vehicle on level ground, and rest the Mega Mixer on a solid, level surface.

STEP 2: Shut off the vehicle and relieve all hydraulic pressure.

STEP 3: Remove packing material from the hopper extension.

STEP 4: Disengage the six hinge pins and remove the safety grates:

A. Turn pins upward.

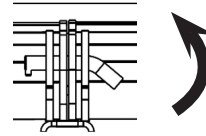

B. Pull pins.

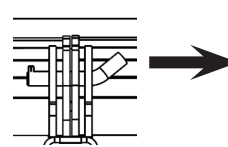

C. Turn pins downward.

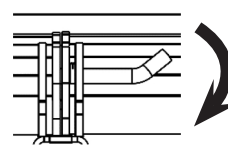

D. Remove safety grates.

STEP 5: With a second person, lift the hopper extension onto the Mega Mixer, allowing it to rest in the four corners of the hopper. If necessary, use a dead-blow hammer or mallet to fully align the hopper extension.

STEP 6: Reinsert the six hinge pins to secure the hopper extension.

STEP 7: Relocate the safety grates atop the hopper extension and secure them with the hopper extension hinge pins.

⚠ DANGER

Do not operate Mega Mixer without safety grates in place and securely latched.

Operation

Scoop & Dispense

! DANGER

The Mega Mixer is designed to be operated from the vehicle seat. Keep bystanders away from the work area. Do not operate with another person in contact with the Mega Mixer.

! WARNING

Personal protection equipment including hard hat, safety glasses, safety shoes, gloves, and hearing protection are recommended during assembly, installation, operation, maintenance, service, removal, or movement of the attachment.

! WARNING

Safe operation of equipment requires the operator's full attention. Avoid distractions such as radio headphones, cell phones, etc. while operating.

! WARNING

Keep hands, feet, hair, jewelry, and clothing away from all moving and/or rotating parts.

! DANGER

Do not use the Mega Mixer as a work platform.

! DANGER

Stay away from power lines when transporting, raising, or operating the attachment. Electrocution can occur without direct contact.

! WARNING

Before you operate the attachment, check over pins and connections to be sure all are securely in place. Make sure the Mega Mixer is securely latched to the vehicle. Make sure the safety grates are properly installed.

STEP 1: Ensure the Mega Mixer is properly attached, discharge gate is closed, and chutes are either removed or located in the storage positions with klik pins installed.

STEP 2: Add material(s) to the hopper. If scooping, raise the hopper and tilt forward until the scraper edge is parallel with the ground. Approach the loose pile of material(s). Engage the pile with the scraper edge. While driving forward with care, tilt back and lift up to scoop.

! WARNING

Do not exceed the vehicle's rated operating load. If necessary, use sufficient counterweights.

NOTE Do not attempt to dig with the Mega Mixer.

! DANGER

Do not operate Mega Mixer without safety grates in place and securely latched.

STEP 3: Position the vehicle and, if necessary, attach additional chute(s) to reach the desired dispensing location.

NOTE If length of additional chutes exceeds 10 feet, then additional support must be added.

Connect chain between hopper and chute(s)

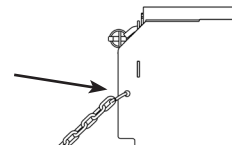

! DANGER

For operator safety, always keep the load in front of the vehicle. Load should never be tilted toward or positioned over the operator.

Operation

(continued)

DANGER

Do not allow riders on the equipment at any time. There is no safe place for any riders.

WARNING

Never place yourself between the vehicle and the attachment.

WARNING

Carry the load low. A heavy load can cause instability of the vehicle. Use extreme care during travel. Slow down on turns and watch out for bumps. Use all safety devices, including a seat belt, as recommended in the vehicle operator's manual.

If the Mega Mixer is equipped with the hydraulic gate, follow Steps 4-6. If not, skip to Step 7.

STEP 4: Activate the electrical control switch.

STEP 5: Activate the auxiliary hydraulics to open the discharge gate.

STEP 6: Deactivate the electrical control switch. Proceed to Step 8.

STEP 7: Open the discharge gate by rotating the discharge gate handle. The gate lock mechanism will hold the gate open during operation.

STEP 8: Run the auger in the forward direction to dispense the material(s).

DANGER

Do not operate with another person in contact with the Mega Mixer.

Never reach into discharge end of auger.

NOTE

If dispensing and the auger locks up, material may be lodged between the auger and the side of the hopper. Run the auger in the opposite direction to attempt to remove the bind. If this is unsuccessful, some material(s) may need to be removed. Over a clear, designated area, lift the hopper and tilt it forward in increments, testing the auger until the auger breaks free and begins moving material again.

STEP 9: Shut off the vehicle's auxiliary hydraulics when dispensing is complete.

If the Mega Mixer is equipped with the hydraulic gate, follow Steps 10-12. If not, skip to Step 13.

STEP 10: Activate the electrical control switch.

STEP 11: Activate the auxiliary hydraulics to close the discharge gate.

STEP 12: Deactivate the electrical control switch.

STEP 13: While holding the discharge gate handle in the open position, pull up on the gate lock handle. Once the gate lock is disengaged, rotate the discharge gate handle to close the gate.

Operation

Concrete Mixing &
Dispensing

DANGER

The Mega Mixer is designed to be operated from the vehicle seat. Keep bystanders away from the work area. Do not operate with another person in contact with the Mega Mixer.

WARNING

Exposure to silica dust and other dust hazards can cause serious or fatal respiratory disease. Use appropriate respiratory protection.

WARNING

Personal protection equipment including hard hat, safety glasses, safety shoes, gloves, and hearing protection are recommended during assembly, installation, operation, maintenance, service, removal, or movement of the attachment.

WARNING

Safe operation of equipment requires the operator's full attention. Avoid distractions such as radio headphones, cell phones, etc. while operating.

DANGER

Stay away from power lines when transporting, raising, or operating the attachment. Electrocution can occur without direct contact.

WARNING

Before you operate the attachment, check over pins and connections to be sure all are securely in place. Make sure the Mega Mixer is securely latched to the vehicle. Make sure the safety grates are properly installed.

STEP 1: Ensure the Mega Mixer is properly attached, and the discharge gate is closed. Add dry material(s) to the dispensing end of the hopper and liquid to the motor end.

NOTE

Use the safety grates to break open bags by tossing a bag onto the bag breakers and rocking the bag back and forth until it splits, dumping material(s) into the hopper.

DANGER

Do not operate Mega Mixer without safety grates in place and securely latched.

STEP 2: Run the auger in reverse to bring the dry material(s) to the liquid.

STEP 3: Add more dry material(s) and liquid to get the volume and mixture required.

NOTE

If mixing and the auger locks up, material may be lodged between the auger and the side of the hopper. Run the auger in the opposite direction to attempt to remove the bind.

NOTE

A thin or wet mix may leak when the auger is run forward.

WARNING

Do not exceed the vehicle's rated operating load. If necessary, use sufficient counterweights.

NOTE

If the mixture becomes too dry, it may be necessary to shovel material from the sides and corners of the hopper. Follow the steps to shovel material(s):

DANGER

Do not operate with another person in contact with the Mega Mixer.

Never reach into discharge end of auger.

Operation

(continued)

! WARNING

Keep hands, feet, hair, jewelry, and clothing away from all moving and/or rotating parts.

! DANGER

Do not use the Mega Mixer as a work platform.

! DANGER

Do not allow riders on the equipment at any time. There is no safe place for any riders.

! WARNING

Never place yourself between the vehicle and the attachment.

! DANGER

Keep clear of auger while in operation. Never position the material by hand or with any tool when the auger is rotating.

1. If material begins to build up on the sides of the hopper, stop mixing.
2. Rest the Mega Mixer on a solid, level surface, and deactivate all hydraulics.
3. Open the safety grate(s) to gain access to the inside of the hopper. (The hinge pins on the opposite side should remain engaged to serve as a hinge point.)

- A. Turn pins upward.

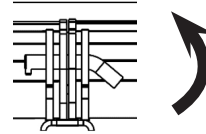

- B. Pull pins.

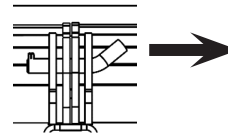

- C. Turn pins downward.

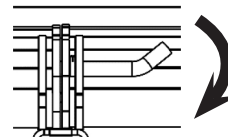

- D. Open safety grate(s).

! WARNING

Ensure safety grates are properly resting in the open position.

4. Shovel the material away from the sides and toward the center of the hopper.
5. Close and secure the safety grate(s).

! DANGER

Do not operate Mega Mixer without safety grates in place and securely latched.

Operation

(continued)

STEP 4: When mixing is complete, position the vehicle and, if necessary, attach additional chute(s) to reach the desired dispensing location.

NOTE

If length of additional chutes exceeds 10 feet, then additional support must be added.

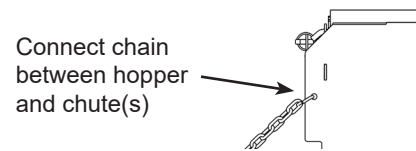

! DANGER

For operator safety, always keep the load in front of the vehicle. Load should never be tilted toward or positioned over the operator.

! WARNING

Carry the load low. A heavy load can cause instability of the vehicle. Use extreme care during travel. Slow down on turns and watch out for bumps. Use all safety devices, including a seat belt, as recommended in the vehicle operator's manual.

If the Mega Mixer is equipped with the hydraulic gate, follow Steps 5-7. If not, skip to Step 8.

STEP 5: Activate the electrical control switch.

STEP 6: Activate the auxiliary hydraulics to open the discharge gate.

STEP 7: Deactivate the electrical control switch. Proceed to Step 9.

STEP 8: Open the discharge gate by rotating the discharge gate handle. The gate lock mechanism will hold the gate open during operation.

STEP 9: Run the auger in the forward direction to dispense the mixture.

! DANGER

Do not operate with another person in contact with the Mega Mixer.

Never reach into discharge end of auger.

NOTE

If dispensing and the auger locks up, material may be lodged between the auger and the side of the hopper. Run the auger in the opposite direction to attempt to remove the bind. If this is unsuccessful, some material(s) may need to be removed. Over a clear, designated area, lift the hopper and tilt it forward in increments, testing the auger until the auger breaks free and begins moving material again.

STEP 10: Shut off the vehicle's auxiliary hydraulics when dispensing is complete.

If the Mega Mixer is equipped with the hydraulic gate, follow Steps 11-13. If not, skip to Step 14.

STEP 11: Activate the electrical control switch.

Operation

(continued)

Cleaning

DANGER

Never attempt adjustments, service, or repairs while the equipment is in operation.

DANGER

Never allow anyone under the attachment at any time.

WARNING

Keep hands, feet, hair, jewelry, and clothing away from all moving and/or rotating parts.

WARNING

Personal protection equipment including hard hat, safety glasses, safety shoes, gloves, and hearing protection are recommended during assembly, installation, operation, maintenance, service, removal, or movement of the attachment.

WARNING

Safe operation of equipment requires the operator's full attention. Avoid distractions such as radio headphones, cell phones, etc. while operating.

STEP 12: Activate the auxiliary hydraulics to close the discharge gate.

STEP 13: Deactivate the electrical control switch.

STEP 14: While holding the discharge gate handle in the open position, pull up on the gate lock handle. Once the gate lock is disengaged, rotate the discharge gate handle to close the gate.

Depending upon the material dispensed, it may be necessary to add a cleaner or appropriate releasing agent to aid in cleaning the Mega Mixer.

STEP 1: Open the discharge gate and run the Mega Mixer until all the material is dispensed.

STEP 2: A second person, standing a safe distance away from the Mega Mixer, should add water to the dispensing end of the hopper while the operator runs the auger in reverse, agitating the water and cleaning the hopper.

DANGER

Do not operate with another person in contact with the Mega Mixer.

Never reach into discharge end of auger.

STEP 3: Run the auger in the forward direction to dispense the watery mixture.

NOTE

If necessary, raise the hopper and tilt it forward to rinse out any remaining material.

NOTE

If necessary to clean build-up in hard-to-reach areas, open the safety grate(s) as previously described in *Operation*. Once build-up is removed, close and securely latch the safety grate(s).

DANGER

Do not operate Mega Mixer without safety grates in place and securely latched.

STEP 4: Level the Mega Mixer, shut off the vehicle engine, relieve all hydraulic pressure, and remove the vehicle key before leaving the vehicle seat.

STEP 5: Remove any material build-up on the motor and on the intermediate mount.

STEP 6: Clean underneath the flap and inside of the discharge tube.

STEP 7: Leave discharge gate in open position to allow liquid(s) to escape during storage.

NOTE

Do not allow material(s) to dry or water to freeze in the hopper. This will cause damage to the auger and the hopper.

STEP 8: Depending upon the material dispensed, coat the hopper with a rust protectant, concrete releasing agent, or asphalt releasing agent.

STEP 9: Lubricate the auger bearing.

Removal & Storage

DANGER

Never allow anyone under the attachment at any time.

WARNING

Personal protection equipment including hard hat, safety glasses, safety shoes, gloves, and hearing protection are recommended during assembly, installation, operation, maintenance, service, removal, or movement of the attachment.

CAUTION

Always use two people to handle heavy, unwieldy components during assembly, installation, maintenance, service, removal, or movement of the attachment.

Before storage, the Mega Mixer should be thoroughly cleaned (refer to *Cleaning*). Make sure the hydraulic system is properly sealed against contaminants entering the unit. Always store the Mega Mixer in a dry, covered location.

STEP 1: Lower the Mega Mixer onto a flat, level surface in an area where children do not play.

STEP 2: Disconnect the hydraulic hoses from the vehicle's auxiliary hydraulics.

WARNING

Before disconnecting hydraulic lines or fittings, be sure to relieve all pressure by cycling all hydraulic controls after shutdown. Remember hydraulic systems are under pressure whenever the engine is running and may hold pressure after shutdown.

NOTE

Connect the quick couplers together to prevent contaminants from entering the Mega Mixer's hydraulic system.

STEP 3: If equipped with the hydraulic gate, disconnect the wiring harness.

STEP 4: Follow your vehicle operator's manual for removing an attachment. Securely block and support the attachment.

STEP 5: Tighten any loose nuts, bolts, and hydraulic components.

STEP 6: Replace any damaged or missing safety signs.

Troubleshooting

Problem	Possible Cause	Solution
Auger does not rotate	Air in hydraulic system	Actuate hydraulics until auger has made one full rotation in forward and in reverse.
	Sheared Woodruff key	Remove auger and replace Woodruff key.
	Hydraulic hose pinched or obstructed	Fix pinched hose or remove obstruction.
	Leaking or failed hydraulic hose	Replace hydraulic hose.
	Quick couplers not engaged	Check quick coupler connects to vehicle.
	Vehicle auxiliary hydraulics not activated	Activate auxiliary hydraulics.
	Vehicle low on hydraulic oil	Add hydraulic oil to vehicle.
	Motor damaged	Contact Danuser.
	Auger bearing worn	Inspect and grease or replace bearing.
Auger locked up or compacted	Refer to <i>Concrete Mixing & Dispensing</i> .	
Poor auger performance	Low flow	Check with flow meter. If low, investigate cause.
	Hydraulic hose restrictions	Clear hydraulic hose.
	Dirty oil or filter	Change oil and filter according to vehicle manufacturer's recommendation.
	Low hydraulic system pressure (PSI)	Check with pressure gauge. If low, investigate cause.
	Material build-up in discharge tube	With vehicle disconnected, lift discharge flap and check for build-up within tube. Clean out as necessary.
	Material(s) too large	Reduce material size.
Cab door hits Mega Mixer	Mega Mixer not properly attached to vehicle	Ensure vehicle locking pins are engaged. Check that the intermediate connection is seated properly and connecting pins are installed.
	Intermediate mount too high	Refer to <i>Intermediate Mount Adjustment</i> .
	Vehicle arms not lowered completely	Lower vehicle's lifting arms, setting Mega Mixer feet on ground.
Mega Mixer hits vehicle wheels/tracks	Mega Mixer not properly attached to vehicle	Ensure vehicle locking pins are engaged. Check that the intermediate connection is seated properly and connecting pins are installed.
	Intermediate mount too low	Refer to <i>Intermediate Mount Adjustment</i> .
Leaking hopper	Material dispensing too thin	Discharge gate will not hold very thin material (e.g., water). Run auger continuously in reverse or thicken material.
	Discharge faceplate not completely secured	Inspect four bolts on discharge faceplate, and tighten to specified torque if necessary.
	Worn motor seal	Replace motor seal.
	Damaged hopper	Contact Danuser.
Safety grate hinge pins hard to retract	Hinge pin not oriented upward	Ensure roll pin faces upward and aligns with slot in ears.
	Safety grates obstructed	Ensure no material is jammed between safety grates and ears.
	Safety grates misaligned	Adjust safety grates so all hinge pins are seated properly.
Safety grates hard to open	Hinge pin not oriented downward	Ensure roll pin faces downward so hinge pin clears hole in safety grate.
	Safety grates obstructed	Ensure no material is jammed between safety grates and ears.
	Hinge pins not fully retracted	Check hinge pins fully clear edges of safety grates.
	Hinge pins not fully engaged	Check opposite side pivot point hinge pins are fully engaged.

Troubleshooting

Problem	Possible Cause	Solution
Discharge gate not closing	Gate lock mechanism is engaged	Disengage gate lock mechanism by pulling up on locking handle.
	Gear teeth misaligned with gate slots	Ensure gear teeth are correctly aligned.
Discharge gate not staying open	Gate lock mechanism not engaged	Engage gate lock mechanism when gate is in the fully open position.

For additional assistance, please call your dealer or contact Danuser direct:

Tel: (573) 642-2246

E-mail: sales@danuser.com

Maintenance & Lubrication

⚠ DANGER

Never attempt adjustments, service, or repairs while the equipment is in operation.

⚠ DANGER

Never allow anyone under the attachment at any time.

⚠ DANGER

Never work under equipment supported by hydraulics. Even with the vehicle shut off, equipment can suddenly drop if controls are actuated or if hydraulic lines burst.

⚠ WARNING

Personal protection equipment including hard hat, safety glasses, safety shoes, gloves, and hearing protection are recommended during assembly, installation, operation, maintenance, service, removal, or movement of the attachment.

Proper servicing and maintenance are key to the long life of any attachment. Careful inspection and routine maintenance help avoid costly downtime and repair. Do not use the Mega Mixer with any damaged parts.

⚠ WARNING

Never check pressurized system for leaks with your bare hand. Wear proper hand and eye protection and use wood or cardboard when searching for suspected leaks. Oil escaping from pinhole leaks under pressure can penetrate skin and create a serious medical emergency. If any fluid is injected into the skin, gangrene, blood poisoning, even death may result. Obtain medical attention immediately.

⚠ WARNING

Do not modify the attachment. Modifications may weaken the integrity of the attachment and may impair the safety, function, life, and performance of the Mega Mixer.

⚠ CAUTION

When making repairs or servicing the Mega Mixer, use only parts that meet the original equipment manufacturer's standards and requirements.

Maintenance	Interval
Inspect the attachment for any damage, worn parts, or cracked welds. Repair or replace as necessary.	Before each use
Check for damaged or missing safety signs. Replace as necessary.	Before each use
Check all fasteners. Ensure they are tight and secure. (Refer to <i>Torque Values Chart</i> .) Replace as necessary.	Daily
Check all hydraulic components for leaks or wear. Repair or replace as necessary.	Daily

Auger Bearing Lubrication

- STEP 1: Open the discharge gate.
- STEP 2: Turn off vehicle and relieve hydraulic pressure.
- STEP 3: Locate the grease zerk under the discharge flap.
- STEP 4: Add multi-purpose grease to lubricate the auger bearing. Adding until grease emerges.

Maintenance & Lubrication

(continued)

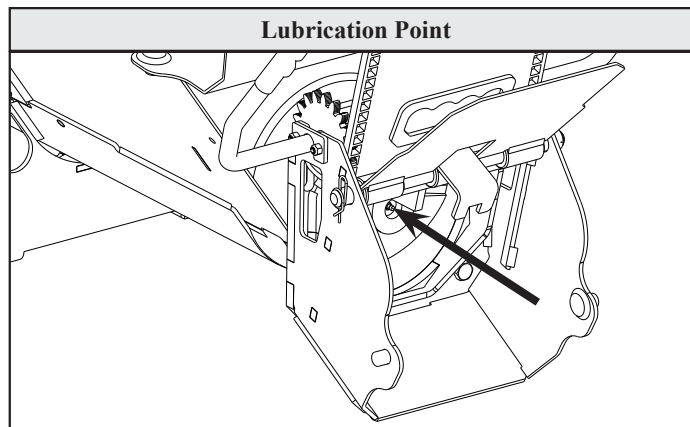

Auger Bearing - 1 Zerk

Add multi-purpose grease until grease emerges

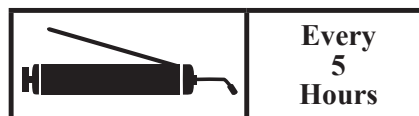

Service

Replacing Auger Bearing

! DANGER

Never attempt adjustments, service, or repairs while the equipment is in operation.

! DANGER

Never allow anyone under the attachment at any time.

! DANGER

Never work under equipment supported by hydraulics. Even with the vehicle shut off, equipment can suddenly drop if controls are actuated or if hydraulic lines burst.

Recommended Tools

- Flat-head screwdriver (2)
- Dead-blow hammer or mallet
- 3/4" socket with ratchet & extension
- 1-1/8" wrench
- 13/16" wrench
- 3/4" wrench (2)
- Hammer
- Chisel
- Punch
- Grease gun

STEP 1: Lower the Mega Mixer onto a solid, level surface.

STEP 2: Shut off the vehicle engine, lower the arms, relieve all hydraulic pressure, and remove the vehicle key before leaving the vehicle seat.

If the Mega Mixer is equipped with the hydraulic gate, follow Steps 3-5. If not, skip to Step 6.

STEP 3: Using 13/16" and 1-1/8" wrenches, remove the nut securing the gate to the hydraulic cylinder. Remove gate by sliding it upward off the cylinder and out of the faceplate.

STEP 4: Using a flathead screwdriver, remove the ratchet clip from the pin beside the hydraulic cylinder. Once removed, remove the pin and discharge flap.

STEP 5: Remove the four nuts and bolts that keep the faceplate on the dispensing end with a 3/4" wrench and 3/4" socket with ratchet and extension. Remove the faceplate and thrust washer from the auger and set to the side. Proceed to Step 7.

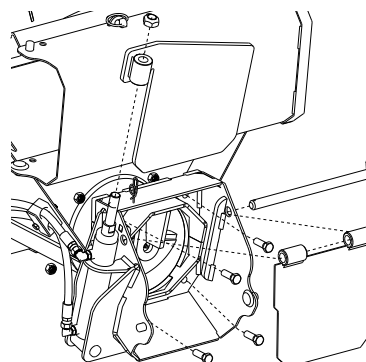

Service

(continued)

⚠ WARNING

Personal protection equipment including hard hat, safety glasses, safety shoes, gloves, and hearing protection are recommended during assembly, installation, operation, maintenance, service, removal, or movement of the attachment.

⚠ CAUTION

Always use two people to handle heavy, unwieldy components during assembly, installation, maintenance, service, removal, or movement of the attachment.

STEP 6: Remove the bottom two nuts and bolts that keep the faceplate on the dispensing end with a 3/4" wrench and 3/4" socket with ratchet and extension. Remove the top two nuts and bolts using two 3/4" wrenches. Remove the faceplate and thrust washer.

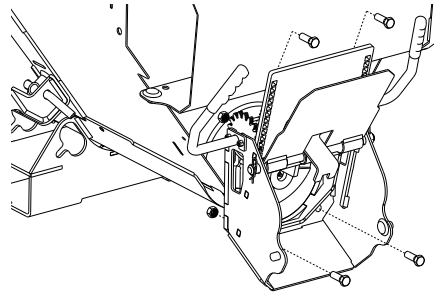

STEP 7: Using a flat-head screwdriver remove the shaft seal.

STEP 8: Using two flat-head screwdrivers, attempt to pry the auger bearing out by wedging the screwdrivers underneath the bearing flange or inside the auger hub.

STEP 9: If the flat-head screwdriver method does not work, attempt to fracture the bearing with a hammer and chisel to gain leverage with the screwdrivers.

STEP 10: Once the auger bearing is removed, clean the bearing mounting surfaces of the auger hub.

STEP 11: Align the replacement auger bearing with the auger hub and using a dead-blow hammer or mallet, install the bearing. A punch or an appropriately sized rod may be needed to fully seat the bearing. The flange face of the bearing should be recessed approx. 1/2" from the end of the auger.

STEP 12: Install the shaft seal. The fabric belting should face the motor end of the auger.

If the Mega Mixer is equipped with the hydraulic gate, follow Steps 13-16. If not, skip to Step 17.

STEP 13: Lightly grease the auger bearing and reinstall the faceplate, thrust washer, bolts, and nuts with a 3/4" wrench and 3/4" socket with ratchet and extension. Tighten the nuts to the torque specified in the *Torque Values Chart*.

STEP 14: Grease the zerk on the faceplate.

STEP 15: Reinstall the discharge flap, pin and ratchet clip.

STEP 16: Reinstall the gate and nut onto the cylinder and tighten using 13/16" and 1-1/8" wrenches.

STEP 17: Lightly grease the auger bearing and reinstall the faceplate, thrust washer, bolts, and nuts with two 3/4" wrenches and 3/4" socket with ratchet and extension. Tighten the nuts to the torque specified in the *Torque Values Chart*.

STEP 18: Grease the zerk located under the discharge flap and gate.

Torque Values Chart

Torque Values Chart																	
Bolt Size (inches)	Bolt Head Identification								Bolt Size (Metric)	Bolt Head Identification							
	Grade 2		Grade 5		Grade 8		ASTM A574			5.8	Class 8.8		Class 10.9		Class 12.9		
in-tpi	Nm	ft.-lb.	Nm	ft.-lb.	Nm	ft.-lb.	Nm	ft.-lb.	mm x pitch	Nm	ft.-lb.	Nm	ft.-lb.	Nm	ft.-lb.	Nm	ft.-lb.
1/4"-20	7.4	5.6	11	8	16	12	19	14	M5 x 0.8	4	3	6	5	9	7	11	8
1/4"-28	8.5	6	13	10	18	14	22	16	M6 x 1	7	5	11	8	15	11	18	13
5/16"-18	15	11	24	17	33	25	39	29	M8 x 1.25	17	12	26	19	36	27	42	31
5/16"-24	17	13	26	19	37	27	43	32	M8 x 1	18	13	28	21	39	29	46	34
3/8"-16	27	20	42	31	59	44	69	51	M10 x 1.5	33	24	52	39	72	53	84	62
3/8"-24	31	22	47	35	67	49	79	58	M10 x 0.75	39	29	61	45	85	62	98	72
7/16"-14	43	32	67	49	95	70	110	81	M12 x 1.75	58	42	91	67	125	93	148	109
7/16"-20	49	36	75	55	105	78	123	91	M12 x 1.5	60	44	95	70	130	97	153	113
1/2"-13	66	49	105	76	145	105	168	124	M12 x 1	90	66	105	77	145	105	167	123
1/2"-20	75	55	115	85	165	120	190	140	M14 x 2	92	68	145	105	200	150	235	173
9/16"-12	95	70	150	110	210	155	235	173	M14 x 1.5	99	73	155	115	215	160	254	187
9/16"-18	105	79	165	120	235	170	262	193	M16 x 2	145	105	225	165	315	230	365	269
5/8"-11	130	97	205	150	285	210	323	238	M16 x 1.5	155	115	240	180	335	245	388	286
5/8"-18	150	110	230	170	325	240	366	270	M18 x 2.5	195	145	310	230	405	300	504	372
3/4"-10	235	170	360	265	510	375	574	423	M18 x 1.5	220	165	350	260	485	355	561	414
3/4"-16	260	190	405	295	570	420	640	472	M20 x 2.5	280	205	440	325	610	450	712	525
7/8"-9	225	165	585	430	820	605	925	682	M20 x 1.5	310	230	650	480	900	665	1052	776
7/8"-14	250	185	640	475	905	670	1020	752	M24 x 3	480	355	760	560	1050	780	1231	908
1"-8	340	250	875	645	1230	910	1386	1022	M24 x 2	525	390	830	610	1150	845	1337	986
1"-12	370	275	955	705	1350	995	1555	1147	M30 x 3.5	960	705	1510	1120	2100	1550	2447	1805
1-1/8"-7	480	355	1080	795	1750	1290	1971	1454	M30 x 2	1060	785	1680	1240	2320	1710	2706	1996
1-1/8"-12	540	395	1210	890	1960	1440	2202	1624	M36 x 3.5	1730	1270	2650	1950	3660	2700	4272	3151
1-1/4"-7	680	500	1520	1120	2460	1820	2771	2044	M36 x 2	1880	1380	2960	2190	4100	3220	5095	3758
1-1/4"-12	750	555	1680	1240	2730	2010	3068	2263	<p>KEY:</p> <p>in-tpi = nominal thread diameter in inches-threads per inch</p> <p>Nm = Newton-meter</p> <p>ft.-lb. = foot pounds</p> <p>mm x pitch = nominal thread diameter in millimeters by thread pitch</p>								
1-3/8"-6	890	655	1990	1470	3230	2380	3638	2683									
1-3/8"-12	1010	745	2270	1670	3680	2710	4143	3056									
1-1/2"-6	1180	870	2640	1950	4290	3160	4823	3557									
1-1/2"-12	1330	980	2970	2190	4820	3560	5426	4002									

Torque tolerance +0%, -15% of torque values. Unless otherwise specified, use torque values listed above.

Parts

⚠️ WARNING

Hopper - Manual Gate

This product can expose you to chemicals known to the State of California to cause cancer and birth defects or other reproductive harm. For more information go to www.P65Warnings.ca.gov/product.

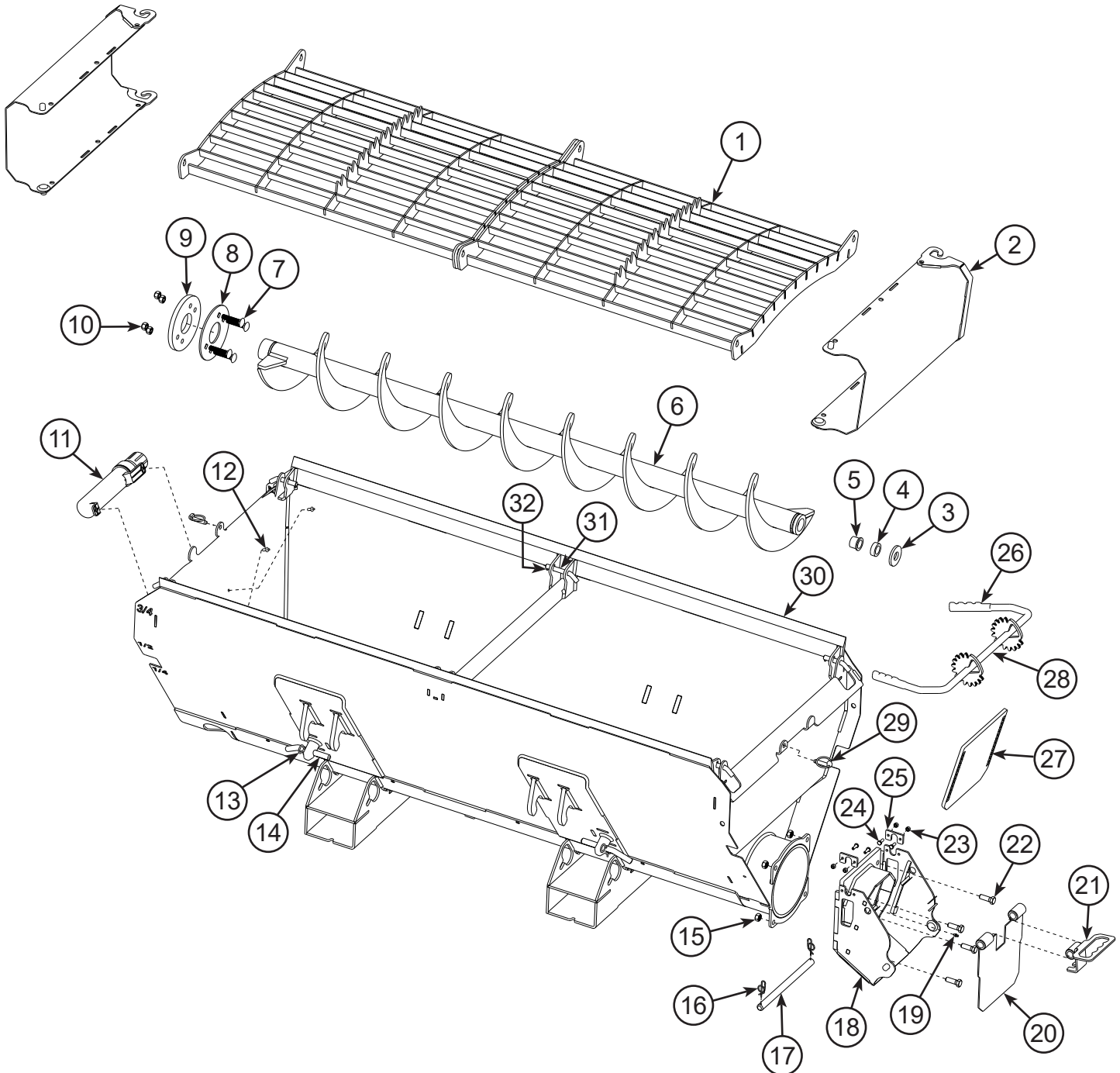

Parts

(continued)

REF. NO.	PART NO.	DESCRIPTION	QTY.
1	170060	Safety Grate	2
2	230205	24" Chute	2
3	230139	Thrust Washer	1
4	236017	Shaft Seal	1
5	236016	Auger Bearing	1
6	230135	Steel Auger Assembly (Includes REF. NOS. 4 & 5)	1
7	176007	Carriage Bolt (1/2"-13 x 2.5", Gr. 5)	4
8	170069	Seal Retaining Plate	1
9	170068	Seal	1
10	10125	Toplock Nut (1/2"-13)	4
11	21258	Operator's Manual Canister	1
12	176033	Drive Rivet	2
13	176028	Hair Pin Cotter	2
14	170071	Connecting Pin	2
15	1056	Hex Nut (1/2"-13)	4
16	21078	Rue Clip	2
17	21079	Pin	1
18	230200	Faceplate Weldment	1
19	35220	Grease Fitting	1
20	170126S	Discharge Flap	1
21	170145	Locking Handle	1
22	12245	Hex Cap Screw (1/2"-13 x 1.5", Gr. 5)	4
23	10195	Toplock Nut (1/4"-20)	4
24	186072	Bolt (1/4"-20 x .75", Gr. 5)	4
25	170129	Handle Clamp	2
26	186060	Handle Grip	2
27	170128	Gate	1
28	170140	Handle Assembly	1
29	1533	Klik Pin	2
30	170010S	Hopper	1
31	170073	Hinge Pin	6
32	176010	Roll Pin (3/16" x 1/2")	6

Parts

! WARNING

Hopper - Hydraulic Gate

This product can expose you to chemicals known to the State of California to cause cancer and birth defects or other reproductive harm. For more information go to www.P65Warnings.ca.gov/product.

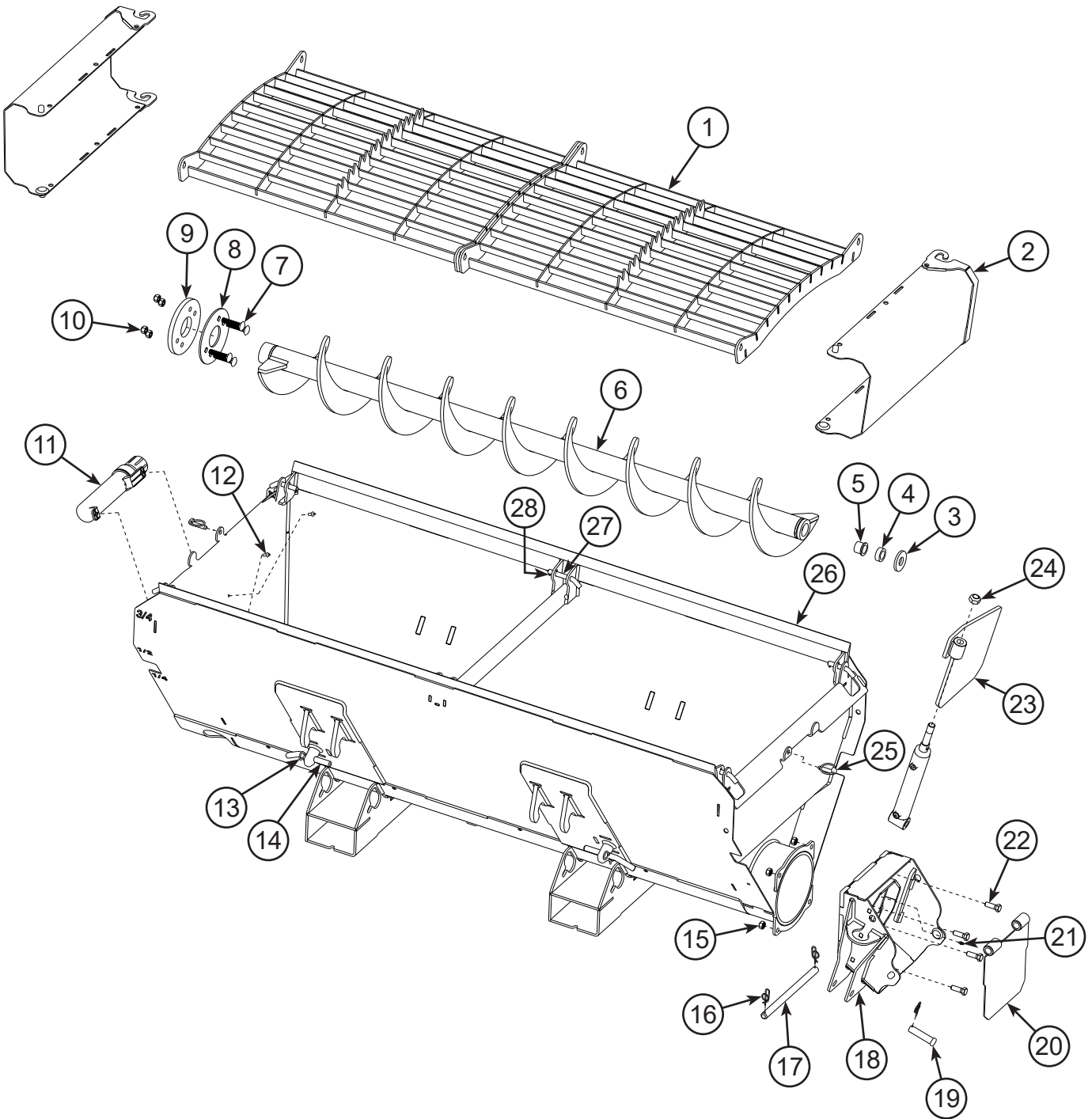

Parts

(continued)

REF. NO.	PART NO.	DESCRIPTION	QTY.
1	170060	Safety Grate	2
2	230205	24" Chute	2
3	230139	Thrust Washer	1
4	236017	Shaft Seal	1
5	236016	Auger Bearing	1
6	230135	Steel Auger Assembly (Includes REF. NOS. 4 & 5)	1
7	176007	Carriage Bolt (1/2"-13 x 2.5", Gr. 5)	4
8	170069	Seal Retaining Plate	1
9	170068	Seal	1
10	10125	Toplock Nut (1/2"-13)	4
11	21258	Operator's Manual Canister	1
12	176033	Drive Rivet	2
13	176028	Hair Pin Cotter	2
14	170071	Connecting Pin	2
15	1056	Hex Nut (1/2"-13)	4
16	21078	Rue Clip	3
17	21079	Pin	1
18	230221	Hydraulic Gate Faceplate Weldment	1
19	206092	Clevis Pin	1
20	230234S	Discharge Flap	1
21	35220	Grease Fitting	1
22	12245	Hex Cap Screw (1/2"-13 x 1.5", Gr. 5)	4
23	230231	Gate Weldment	1
24	10268	Toplock Nut (3/4"-10)	1
25	1533	Klik Pin	2
26	170010S	Hopper	1
27	170073	Hinge Pin	6
28	176010	Roll Pin (3/16" x 1/2")	6

Parts

Intermediate Mount

⚠️ WARNING

This product can expose you to chemicals known to the State of California to cause cancer and birth defects or other reproductive harm. For more information go to www.P65Warnings.ca.gov/product.

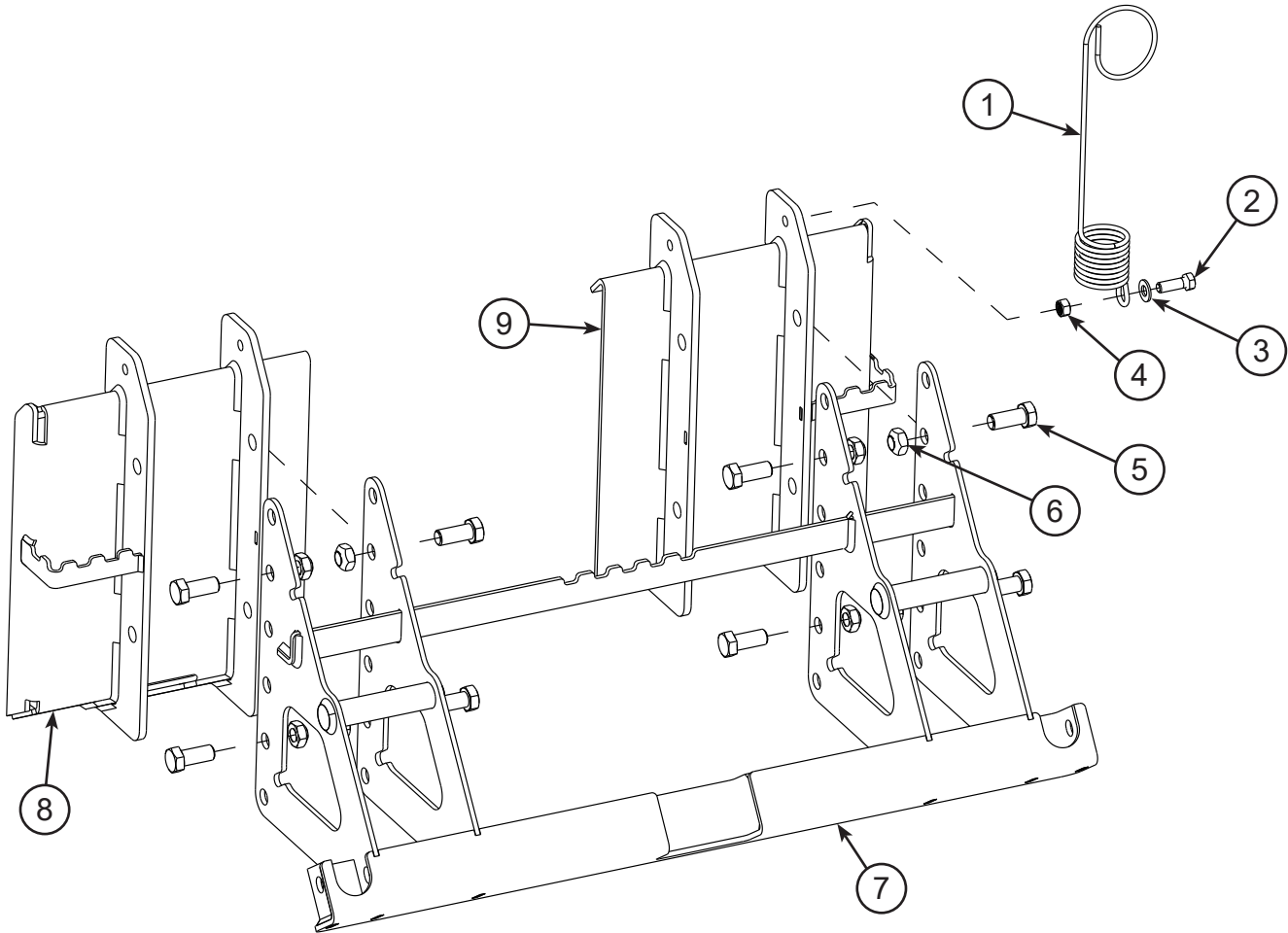

REF. NO.	PART NO.	DESCRIPTION	QTY.
	170075	Intermediate Mount (Includes REF. NOS. 5-9)	1
1	176021	Hose Retention Spring	1
2	12245	Hex Cap Screw (1/2"-13 x 1.5", Gr. 5)	1
3	21156	Flat Washer (1/2")	1
4	1056	Hex Nut (1/2"-13)	1
5	176025	Hex Cap Screw (3/4"-10 x 1.25", Gr. 5)	8
6	10268	Toplock Nut (3/4"-10)	8
7	170080	Intermediate Assembly	1
8	170076	Right Quick Attach Assembly	1
9	170079	Left Quick Attach Assembly	1

Parts

! WARNING

Hydraulics - Manual Gate

This product can expose you to chemicals known to the State of California to cause cancer and birth defects or other reproductive harm. For more information go to www.P65Warnings.ca.gov/product.

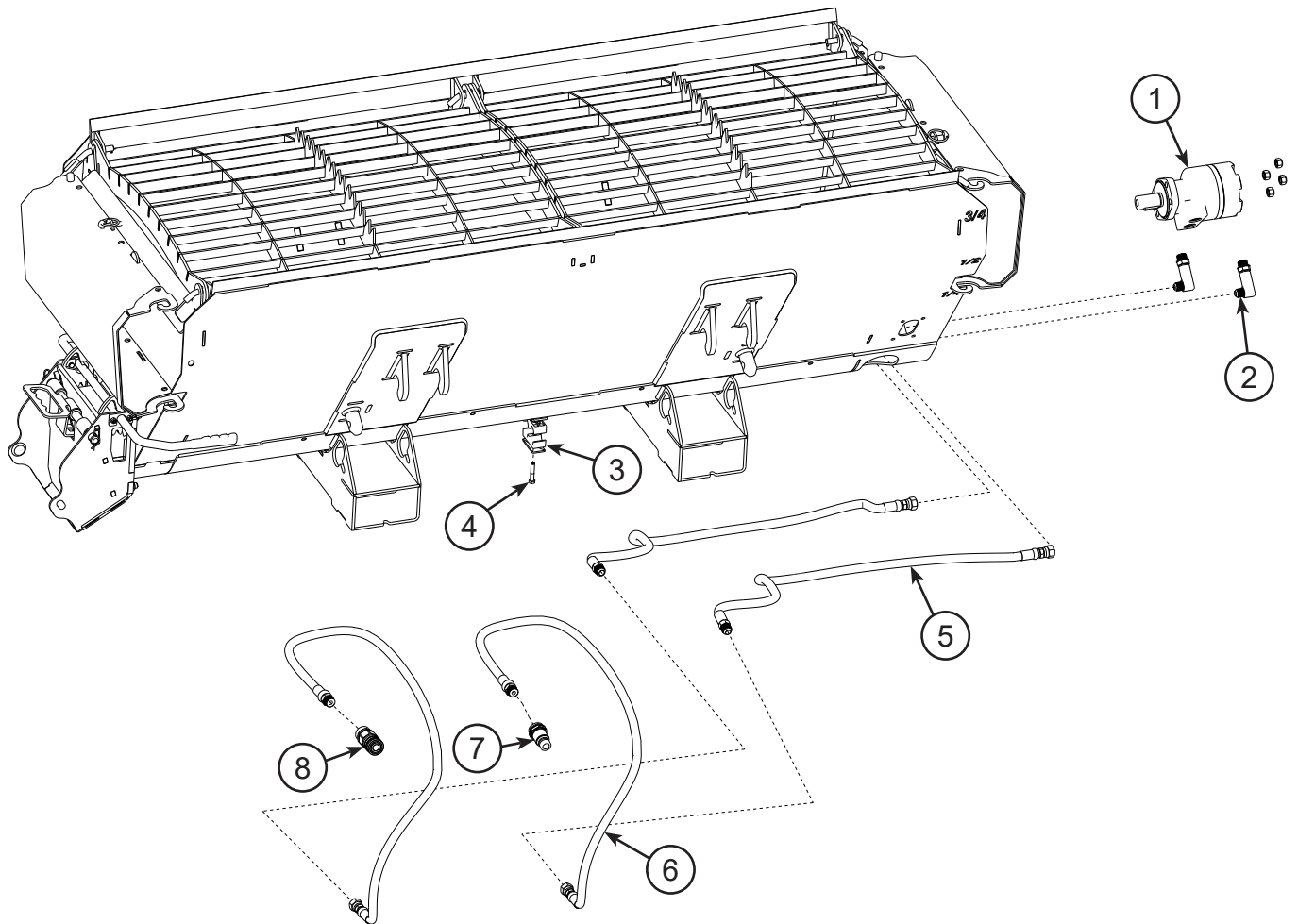

REF. NO.	PART NO.	DESCRIPTION	QTY.
1	186045	Hydraulic Motor	1
	176036	Hydraulic Motor Seal Kit (Not Shown)	
2	176018	Adapter, 90° (#10 JIC M to SAE O-Ring)	2
3	176013	Hydraulic Hose Clamp Kit	1
4	176014	Hex Cap Screw (5/16"-18 x 1.75", Gr. 2)	1
5	176027	1/2" Hose Assembly (#8 JIC F to #10 JIC M)	2
6	176026	1/2" Hose Kit (#10 JIC F to #8 JIC M) (Includes two hoses in double abrasion sleeve)	1
	176037	1/2" Hose Assembly (#10 JIC F to #8 JIC M)	2
	176038	Double Abrasion Sleeve	1
7	10048	Male Coupler (1/2" flush-face, ISO 16028)	1
8	10049	Female Coupler (1/2" flush face, ISO 16028)	1

Parts

! WARNING

Hydraulics - Hydraulic Gate

This product can expose you to chemicals known to the State of California to cause cancer and birth defects or other reproductive harm. For more information go to www.P65Warnings.ca.gov/product.

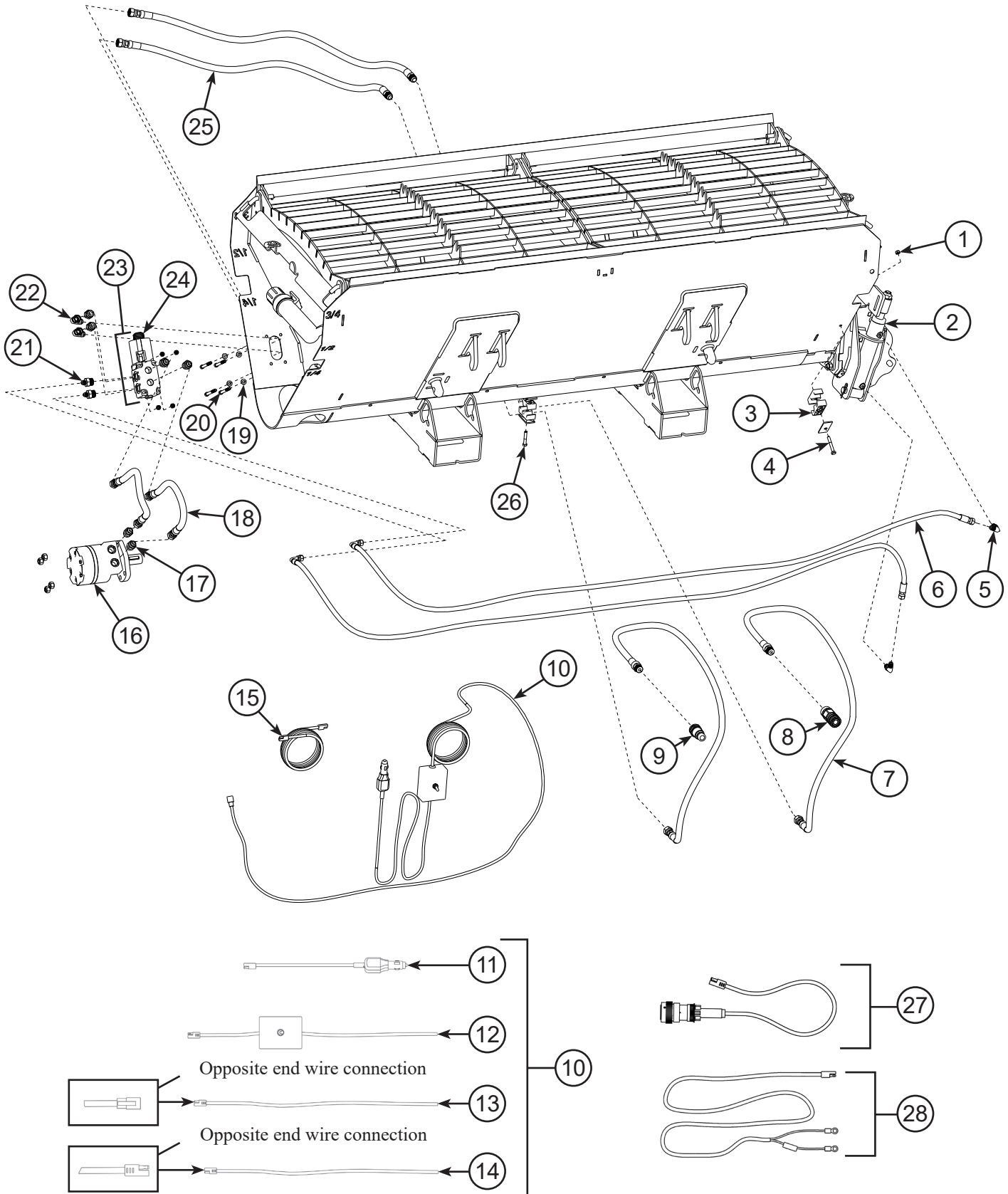

Parts

(continued)

REF. NO.	PART NO.	DESCRIPTION	QTY.
1	21159	Toplock Nut (5/16"-18)	5
2	230230	Hydraulic Cylinder Weldment	1
3	176013	Hydraulic Hose Clamp Kit	2
4	246042	Bolt (5/16"-18 x 2.25", Gr. 5)	1
5	12111	Adapter, 90° (#6 ORB M to #6 JIC M)	2
6	246031	1/4" Hose Assembly (#6 JIC F 90° to #6 JIC F)	2
7	176026	1/2" Hose Kit (#10 JIC F to #8 JIC M) (Includes two hoses in double abrasion sleeve)	1
	176037	1/2" Hose Assembly (#10 JIC F to #8 JIC M)	2
	176038	Double Abrasion Sleeve	1
8	10049	Female Coupler (1/2" flush-face, ISO 16028)	1
9	10048	Male Coupler (1/2" flush-face, ISO 16028)	1
10	21162	Wiring Harness (Includes REF. NOS. 11-14)	1
11	21343	Wire (12-volt Auxiliary Power)	1
12	21344	Wire (Control Switch)	1
13	21345	Wire (Solenoid)	1
14	21346	Wire (Extension)	1
15	21346	Wire (Extension)	1
16	186045	Hydraulic Motor	1
	176036	Hydraulic Motor Seal Kit (Not Shown)	
17	246075	Adapter (#8 JIC M to #10 ORB M)	6
18	246095	1/2" Hose Assembly (#8 JIC F to #8 JIC F)	2
19	6339	Flat Washer (5/16")	4
20	216028	Socket Head Bolt (5/16"-18 x 3.5")	4
21	21153	Adapter (#6 JIC M to #10 ORB M)	2
22	246076	Adapter, 90° (#8 JIC M to #8 JIC F)	2
23	266002	Diverter Valve (Includes REF. NO. 24)	1
24	266003	Diverter Valve Solenoid	1
25	176027	1/2" Hose Assembly (#8 JIC F to #10 JIC M)	2
26	176014	Bolt (5/16"-18 x 1.75", Gr.2)	1
27	*21220	Optional Wiring Harness	1
28	*21253	Optional Wiring Harness (Battery Connection)	1

* For PN and full description, refer to *Accessories*.

Parts

Hopper Extension

⚠️ WARNING

This product can expose you to chemicals known to the State of California to cause cancer and birth defects or other reproductive harm. For more information go to www.P65Warnings.ca.gov/product.

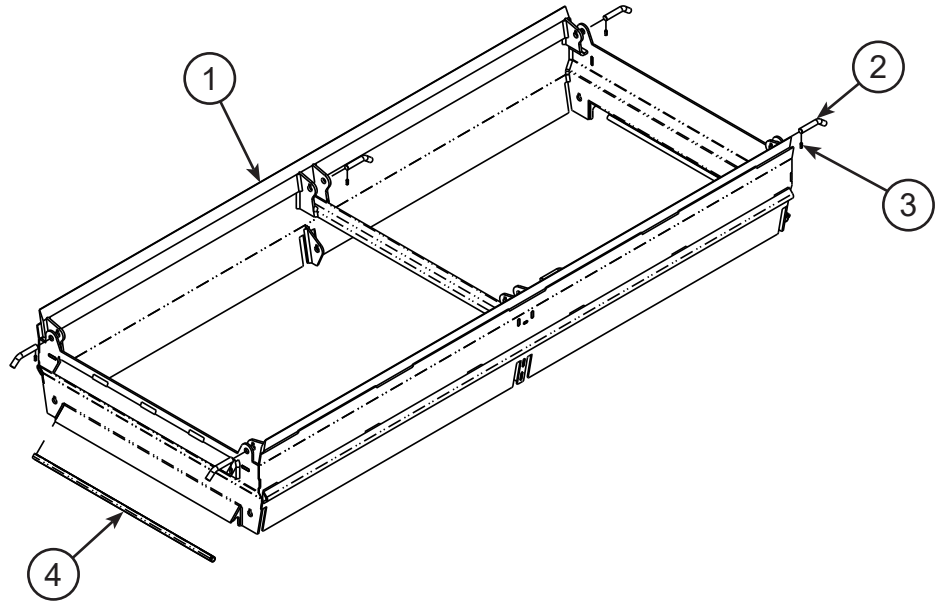

REF. NO.	PART NO.	DESCRIPTION	QTY.
1	170094	Hopper Extension Weldment	1
2	170073	Hinge Pin	6
3	176010	Roll Pin (3/16" x 1/2")	6
4	176004	Weather Stripping	2

Parts

Funnel with 6" Hose
Adapter

⚠️ WARNING

This product can expose you to chemicals known to the State of California to cause cancer and birth defects or other reproductive harm. For more information go to www.P65Warnings.ca.gov/product.

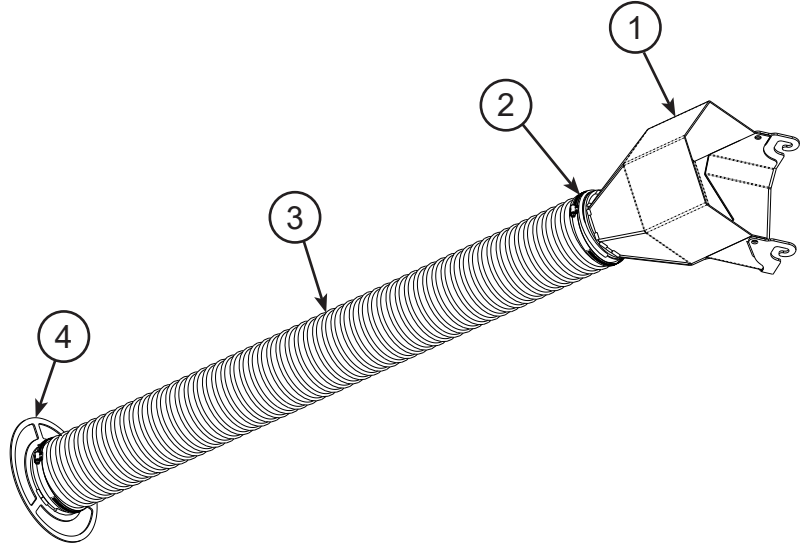

REF. NO.	PART NO.	DESCRIPTION	QTY.
1	230215	Chute Hose Adapter	1
2	176031	Worm-drive Hose Clamp (4.5" to 6")	2
3	176011	Flex Hose	1
4	190204	Handle Weldment - Hose Adapter	1

WARNING

This product can expose you to chemicals known to the State of California to cause cancer and birth defects or other reproductive harm. For more information go to www.P65Warnings.ca.gov/product.

Wiring Harness Options

Danuser takes care to ensure the accuracy of the information contained in this manual. We assume no liability for errors contained herein. It is the responsibility of the installer to ensure that all of the products are correct before installation. Proper assembly always requires that the installer use all instructions and safety procedures. We assume no liability for any errors made in product selection or installation.

Optional wiring harness allows for hydraulic gate operation from the vehicle joystick controls. It replaces the standard harness 12-volt auxiliary power port plug and control switch on the Mega Mixer with hydraulic gate.

- PN 21220-1 - 8-Pin used on ASV, Caterpillar, Komatsu, and Terex
- PN 21220-2 - 14-Pin used on Bobcat (prior to 1999), Case, Kubota, New Holland, Takeuchi, and Volvo
- PN 21220-3 - 14-Pin Deere used on John Deere
- PN 21220-4 - 14-Pin Caterpillar used on Caterpillar
- PN 21220-5 - 14-Pin used on Bobcat (1999 and current) and Gehl
- * PN 21220-U1 - 8-Pin universal wiring harness. Contacts are crimped on wire but not installed in connector.
- * PN 21220-U2 - 14-Pin universal wiring harness. Contacts are crimped on wire but not installed in connector.

* Requires connector contacts be installed in a switchable +12-volt pin location and ground pin location. Mapping of skid-steer connector pins required.

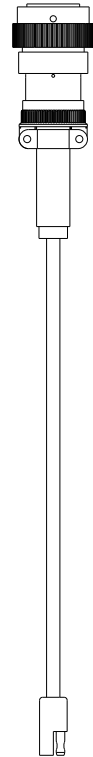

Front-End Loader Hose Kit

PN 196056 - 1/2" hoses, 25' long, with 1/2" flush-face couplers (ISO 16028) on one end to connect to Mega Mixer hoses, and ISO 7241 Series A couplers (compatible with ISO 5675 Pioneer couplers) on the opposite end to connect to tractor rear remotes. Includes bolt-on/weld-on mounting bracket.

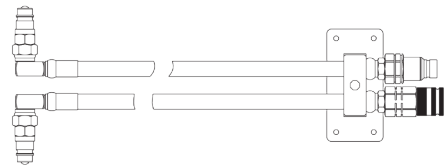

Accessories

(continued)

Hopper Extension

PN 170095 - Expands Mega Mixer capacity from 3/4 yard to 1 yard. Hardware included.

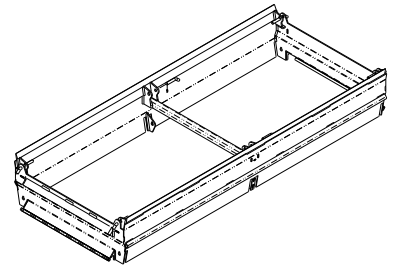

Additional Chutes

PN 230205 - 24" Chute

PN 230210 - 36" Chute

Chutes can be linked to extend length.

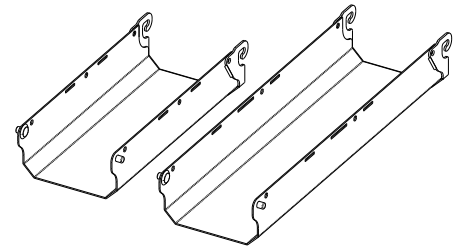

Funnel with 6" Hose Adapter

PN 230214 - Allows precision dispensing with included 5' long, 6" diameter hose.

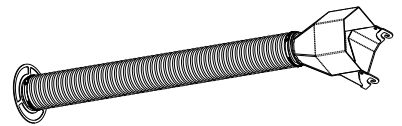

Auger Assembly

PN 230135 - Steel Auger Assembly, includes auger bearing and shaft seal.

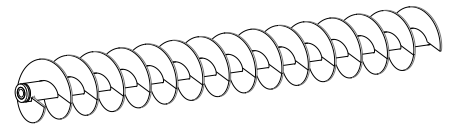

Hydraulic Gate Kit

PN 230220 - Allows the gate to be opened and closed from the cab of the vehicle.

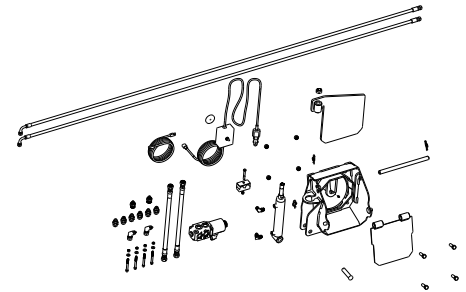

LIMITED WARRANTY

Danuser Machine Company, LLC ("Danuser") warrants its products, under normal use and maintenance, to be free from defects in material and workmanship for period(s) specified below from the purchase date from an authorized Danuser Dealer. Start of the warranty period is determined by purchase date given on your returned WARRANTY REGISTRATION FORM. Proof of purchase may be required. This Limited Warranty is extended only to the original purchaser of Danuser products.

Mega Mixer - 1 Year

Wear Items Not Covered Under Warranty - Hydraulic Hoses, Seals, Weather Stripping, and Auger Flighting

1. During the applicable warranty period, Danuser, at its option, will repair or replace any part determined by Danuser to be defective. Such repair or replacement shall take place at Danuser's factory, or a location designated by Danuser. Under no circumstances shall Danuser be obligated for the cost of any repair or replacement by anyone other than Danuser without its express written consent.
2. Parts may not be returned without written authorization from Danuser.
3. Some purchased components, including but not limited to hydraulic components, are subject to the inspection and warranty of the respective manufacturer. Thus, delays in a warranty determination can be expected while Danuser awaits their decision.
4. This warranty is void if any attempt is made to make field repairs to hydraulic components. To qualify for warranty inspection, the "failed" part(s) must be returned in its original "failed" condition.
5. To make a claim under this warranty, first contact your authorized Danuser Dealer. The Danuser Dealer shall complete the Warranty Claim Form and obtain written authorization from Danuser to return parts. All warranty claims must include detailed information regarding make and model of vehicle on which the Danuser product was mounted, hours of use, description of events that led up to the failure, and any other information helpful in reviewing the warranty claim. All warranty returns must be prepaid. Shipments arriving at our factory on a freight collect basis will be refused by our receiving department. The freight charge will be credited if the parts are determined by Danuser to be defective, and the associated freight costs in returning those parts will be prepaid by Danuser. NOTE: Hydraulic components must arrive with all ports sealed from dirt and moisture. If a hydraulic component arrives with open ports, the warranty is void and no inspection will be made.
6. Products or parts thereof which, as determined by Danuser's examination, show wear from normal use, have been improperly operated, damaged by accident or negligence, field repaired, altered or modified are not considered defective in material and workmanship and are not covered by this warranty. This warranty does not apply to parts subject to normal wear ("Wear Items") or to damage caused by the failure to perform recommended maintenance or to replace worn parts. This warranty shall not obligate Danuser to bear any cost of labor for field repair, replacement, testing, or adjustment nor for damage caused by accident, abuse, misuse, or environmental elements.
7. Any parts or labor required to repair or replace parts not covered under this warranty will be charged to the customer. Parts repaired or replaced by Danuser are then covered by this warranty only for the remainder of the original warranty as if such parts were original parts.
8. Danuser reserves the right to change its specifications and designs at any time.

This warranty is exclusive and in lieu of all other express warranties, if any, including the implied warranties of merchantability and fitness for a particular purpose. It shall not extend beyond the duration of the expressed warranty provided herein and the remedy for violations of any implied warranty shall be limited to repair or replacement of the defective part pursuant to the terms contained herein. No employee, dealer, salesman, or representative is authorized to change this warranty in any way or grant any other warranty. Danuser shall not be liable for any consequential, incidental, or punitive damages, losses, or expenses, including those resulting from or caused by any defects.

Danuser Machine Company, LLC
500 E. 3rd St.
P.O. Box 368
Fulton, MO 65251

Tel: (573) 642-2246
E-mail: sales@danuser.com
Website: www.danuser.com