

MAC BUCKET

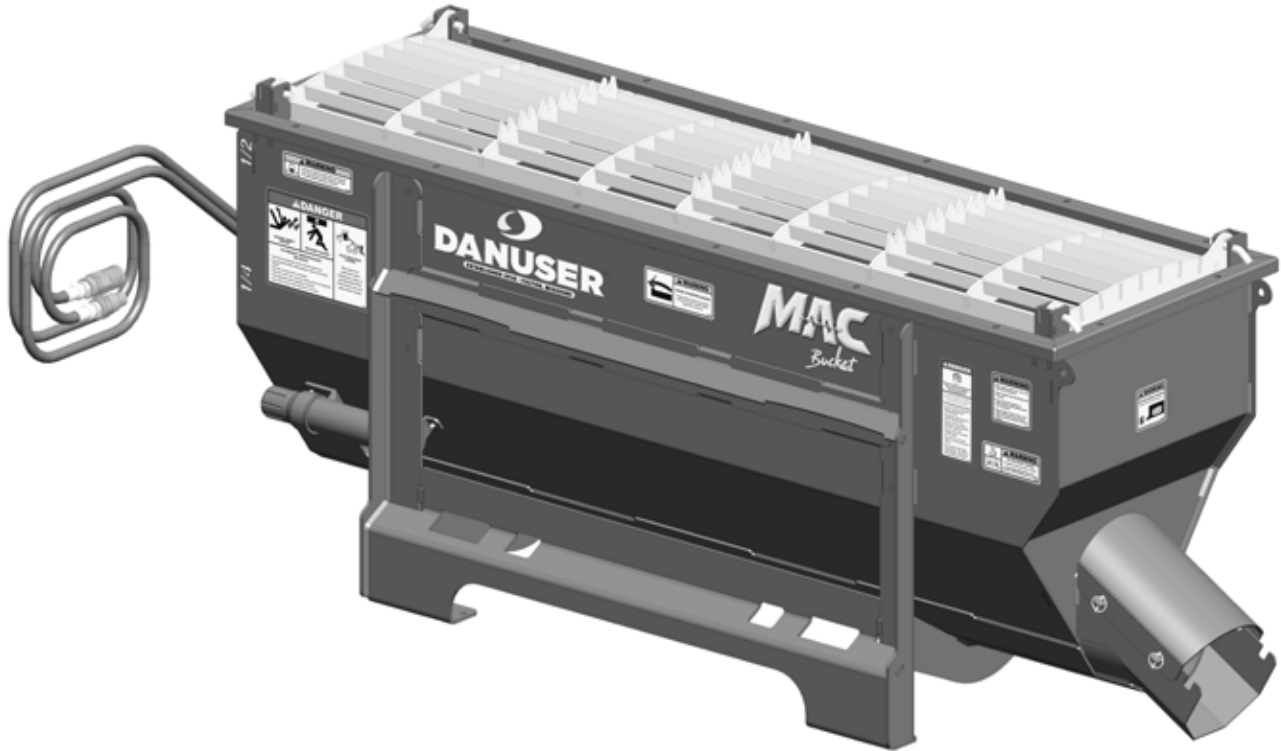

! Read this entire manual. This safety alert symbol is used throughout this manual to call your attention to messages involving your personal safety and the safety of others. Failure to follow these instructions can result in injury or death.

! WARNING

Si no entiende ingles, se prefiere que busque a alguien que interprete las instrucciones para usted.

Owner: _____

Date Purchased: _____

Model #: _____ Serial #: _____

Manual #: 9MMACBUCK2460887

Operator's Manual

Danuser Machine Company, LLC
500 E. 3rd St.
P.O. Box 368
Fulton, MO 65251
Tel: (573) 642-2246
E-mail: sales@danuser.com
Website: www.danuser.com



Dear Owner/Operator,

Thank you for purchasing this Danuser MAC Bucket. We appreciate your business.

With a 1/2 yard capacity, the MAC Bucket is designed to mix, transport, and dispense concrete or other materials where needed.

Your safety as an operator of our product is very important to us. Therefore, *before* you assemble, install, operate, maintain, service, remove, or move your Danuser MAC Bucket, read and understand this manual thoroughly. If there is anything you do not understand, immediately contact your dealer, or contact our factory direct.

Tel: (573) 642-2246
E-mail: sales@danuser.com

Your satisfaction in the performance and longevity of our product is also very important to us and can be prolonged by proper assembly, installation, operation, and maintenance as instructed in this manual.

Thank you again for your business and for your trust in our product. Please feel free to contact us at any time for further assistance.

Sincerely,

Danuser Machine Company, LLC
500 E. 3rd St.
P.O. Box 368
Fulton, MO 65251

Tel: (573) 642-2246
E-mail: sales@danuser.com Website: www.danuser.com

Danuser provides this manual "as is" without warranty of any kind, either expressed or implied. Danuser assumes no responsibility for errors or omissions. Danuser assumes no liability for damages resulting from the use of the information contained herein. Danuser reserves the right to revise and improve its products as it sees fit. This manual describes the state of this product at the time of its publication and may not reflect the product in the future.

Danuser is a registered trademark.

Foreword

Please read this manual thoroughly!

Before you assemble, install, operate, maintain, service, remove, or move your Danuser MAC Bucket, read this manual thoroughly. If there is anything you do not understand, immediately contact your dealer, or call our factory direct at (573) 642-2246. Powered equipment can be dangerous if not assembled, installed, operated, maintained, serviced, removed, or moved properly.

Warranty Registration

To activate your warranty coverage and to provide you with efficient customer service, please fill out your WARRANTY REGISTRATION FORM. This form is included in your unit's paperwork package. If you did not complete a WARRANTY REGISTRATION FORM or did not receive one, please call Danuser. Or, register online at www.danuser.com. Your satisfaction with our product and your safety as a user of our product are both very important to us.

Symbols

 This SAFETY ALERT symbol identifies important safety messages. Carefully read each safety message that follows. Failure to understand and obey a safety message, or recognize a safety hazard, could result in injury or death to you or others around you. The operator is ultimately responsible for the safety of himself, as well as others, in the operating area of the MAC Bucket.





<i>Symbol</i>	<i>Meaning</i>
	Indicates an imminently hazardous situation which, if not avoided, will result in death or serious injury.
	Indicates a potentially hazardous situation which, if not avoided, could result in death or serious injury, including hazards that are exposed when guards are removed.
	Indicates a potentially hazardous situation which, if not avoided, may result in minor or moderate injury. It may also be used to alert against unsafe practices.
	This is important information for proper use of this equipment. Failure to comply may lead to premature equipment failure.

Table of Contents

	Page
Letter to Owner/Operator	2
Foreword	3
Symbols	3
Safety	4
Decals & Safety Signs	7
Specifications	9
Hydraulic Requirements	10
Assembly & Installation	11
Operation	14
Cleaning	18
Removal & Storage	19
Troubleshooting	20
Maintenance & Lubrication	21
Service	22
Torque Values Chart	23
Parts	24
Accessories	26
Warranty	PD 5052A

WARNING

Working with familiar equipment can lead to careless injuries. Read and understand this manual and the manual for your vehicle before assembling, installing, operating, maintaining, servicing, removing, or moving the Danuser MAC Bucket. If there is anything in this manual you do not understand, contact your dealer or Danuser. The safe use of this attachment is strictly up to you, the operator. If this attachment is used, loaned, or rented by any other person, it is the owner's responsibility to make certain that the operator prior to operating:

- Reads and understands the Operator's Manual
 - Is instructed in safe and proper use
-
- The MAC Bucket is designed to be operated from the vehicle operator station. Keep bystanders away from the work area. Do not operate with another person in contact with any part of the MAC Bucket.
 - All operators of this attachment must read and understand this entire manual, paying particular attention to safety messages and operation instructions prior to assembling, installing, operating, maintaining, servicing, removing, or moving the MAC Bucket.
 - Please remember it is also important that you read, understand, and follow the safety signs on the attachment. Clean or replace all safety signs if they cannot be clearly read and understood. They are there for your safety as well as the safety of others. Danuser will furnish new safety signs upon request at no charge.
 - All things with moving parts are potentially hazardous. There is no substitute for a cautious, safe-minded operator who recognizes potential hazards and follows reasonable safety practices.
 - Personal protection equipment including hard hat, safety glasses, safety shoes, gloves, and hearing protection are recommended during assembly, installation, operation, maintenance, service, removal, or movement of attachment.
 - Exposure to silica dust and other dust hazards can cause serious or fatal respiratory disease. Use appropriate respiratory protection.
 - When the use of hand tools is required to perform any part of assembly, installation, operation, maintenance, or service of the attachment, be sure the tools used are designed and recommended by the tool manufacturer for that specific task.
 - Never check pressurized system for leaks with your bare hand. Wear proper hand and eye protection and use wood or cardboard when searching for suspected leaks. Oil escaping from pinhole leaks under pressure can penetrate skin and create a serious medical emergency. If any fluid is injected into the skin, gangrene, blood poisoning, even death may result. Obtain medical attention immediately.
 - Always use two people to handle heavy, unwieldy components during assembly, installation, maintenance, service, removal, or movement of the attachment.
 - Never place any part of your body where it would be in danger if movement should occur during assembly, installation, operation, maintenance, service, removal, or movement of the MAC Bucket.
 - Only properly trained people should operate the equipment. Do not allow anyone who has not read this entire manual and understood the safety rules, safety signs, and operation instructions to use this attachment.
 - Never allow children to operate or be around the MAC Bucket.
 - Do not use the MAC Bucket as a work platform.

Safety

(continued)

- Do not allow riders on the equipment at any time. There is no safe place for any riders.
- Never use alcoholic beverages or drugs which can hinder alertness or coordination while operating this equipment. Consult your doctor about operating the equipment while taking prescription or over-the-counter medications.
- Safe operation of equipment requires the operator's full attention. Avoid distractions such as a radio, headphones, cell phones, etc. while operating.
- Stay away from power lines when transporting, raising, or operating the attachment. Electrocutation can occur without direct contact.
- The MAC Bucket must be securely latched to the vehicle. Ensure both locking handles are in the locked position with pins fully seated. An improperly latched MAC Bucket can fall without warning.
- Make sure safety grate is in place and secured before operating equipment.
- Keep hands, feet, hair, jewelry, and clothing away from all moving and/or rotating parts.
- Never place yourself between the vehicle and the attachment.
- Never allow anyone under the attachment at any time.
- Never reach into discharge end of auger.
- Keep clear of auger while in operation. Never position the material by hand or with any tool when the auger is rotating.
- Do not exceed the vehicle's rated operating load. Use sufficient counterweights. Move the vehicle slowly when the attachment is raised.
- Carry the load low. A heavy load can cause instability of the vehicle. Use extreme care during travel. Slow down on turns and watch out for bumps. Use all safety devices, including a seat belt, as recommended in the vehicle operator's manual.
- For operator safety, always keep the load in front of the vehicle. Load should never be tilted toward or positioned over the operator.
- Do not operate the MAC Bucket on steep hillsides. When operating the MAC Bucket on uneven or hilly terrain, position the vehicle with the attachment uphill. With the attachment downhill, the vehicle could tip when attempting to raise the MAC Bucket. Consult your vehicle operator's manual for maximum incline allowable.
- Always shut off the vehicle engine, remove the key, lower vehicle arms, and relieve all hydraulic pressure before dismounting the vehicle. Never leave equipment unattended with the vehicle running.
- Never attempt adjustments, service, or repairs while the equipment is in operation.
- Never work under equipment supported by hydraulics. Even with the vehicle shut off, equipment can suddenly drop if controls are actuated or if hydraulic lines burst.
- Before connecting or disconnecting hydraulic lines or fittings, be sure to relieve all pressure by cycling all hydraulic controls after shutdown. Remember hydraulic systems are under pressure whenever the engine is running and may hold pressure after shutdown.
- Store the attachment on a flat, level surface where children do not play. Securely block and support the attachment.

Safety

(continued)

- Do not modify the attachment. Modifications can weaken the integrity of the attachment and may impair the safety, function, life, and performance of the MAC Bucket.
- When making repairs or servicing the MAC Bucket, use only parts that meet the original equipment manufacturer's standards and requirements.
- Always use care when operating the MAC Bucket. Most accidents occur because of neglect or carelessness.

Safety is a primary concern in the design, manufacture, sale, and use of the MAC Bucket. Danuser confirms to you, our customer, our concern for safety.

DANGER

Improper operation of this MAC Bucket can cause serious personal injury or death. Operation of this attachment should only be done by a competent adult acting in compliance with the Operator's Manual. Since MAC Bucket operations are beyond our control, we disclaim all liability for any damages, injuries or death which may result.

CALIFORNIA WARNING

This product can expose you to chemicals including lead, which are known to the State of California to cause cancer and birth defects or other reproductive harm. For more information go to www.P65Warnings.ca.gov.

Decals & Safety Signs

The MAC Bucket comes equipped with all safety signs in place. Their locations are shown in this section. Read and follow their instructions and ensure their care:

- Keep safety signs clean and legible at all times.
- Replace safety signs that are missing, illegible, or damaged.
- Ensure replacement parts installed during repair have safety signs attached.

To install new safety signs, follow these steps:

1. Clean the area where the safety sign is to be placed.
2. Spray a little soapy water on the surface where the safety sign is to be placed.
3. Peel the backing from the safety sign, and apply it in the position shown.
4. Firmly press the safety sign, and squeeze out the air bubbles with a straight edge (e.g., a credit card).

PART NO. DIG47

Locations: Hopper, both sides

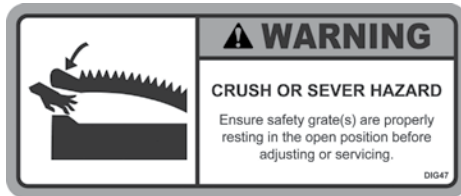

PART NO. 246035

Locations: Hopper, both sides



PART NO. DIG15

Locations: Hopper, both sides



PART NO. DANUSER109

Locations: Hopper, both sides

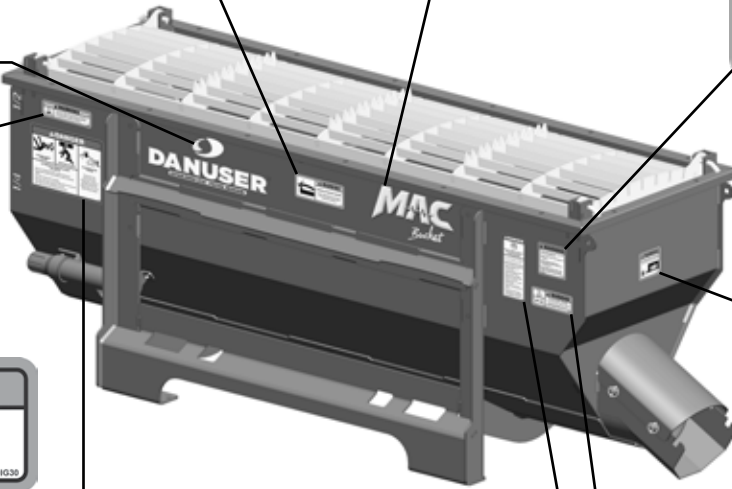

PART NO. DIG52

Location: Hopper, discharge end



PART NO. DIG30

Locations: Hopper, both sides

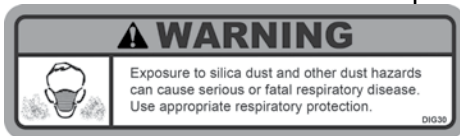

PART NO. DIG13

Locations: Hopper, both sides



PART NO. DIG35

Locations: Hopper, both sides

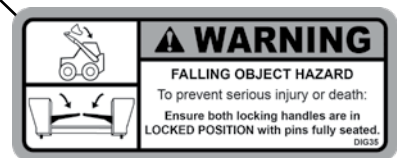

PART NO. DIG46

Locations: Hopper, both sides



WARNING
Clean or replace all safety signs if they cannot be clearly read and understood.

Decals & Safety Signs

(continued)

Model No. & Serial No.

Location: Hopper, motor end

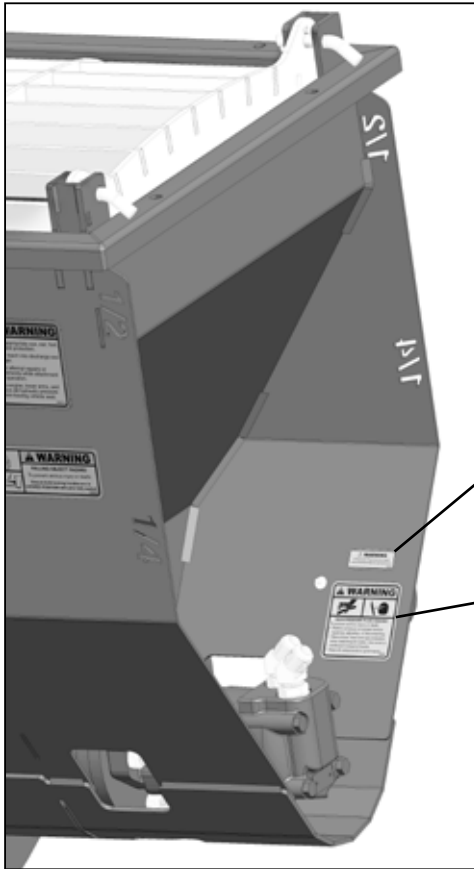
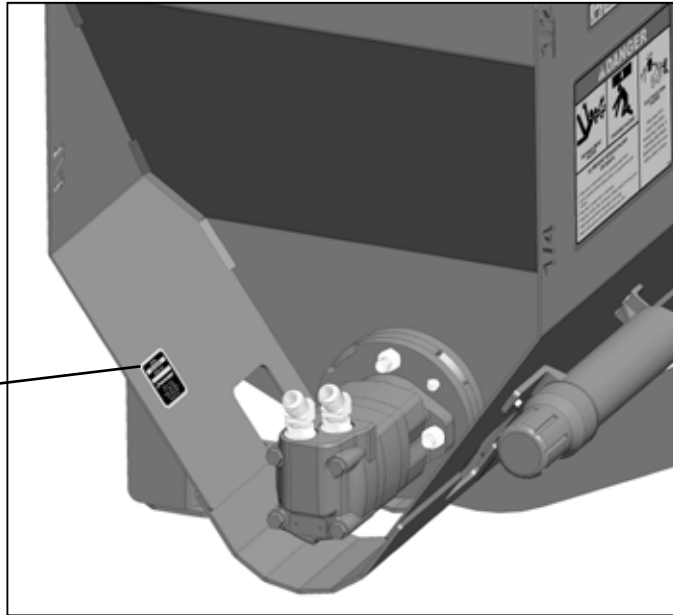

PART NO. CA65

Location: Hopper, motor end

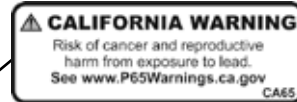

PART NO. DIG5

Location: Hopper, motor end



⚠️ WARNING

Clean or replace all safety signs if they cannot be clearly read and understood.

Specifications

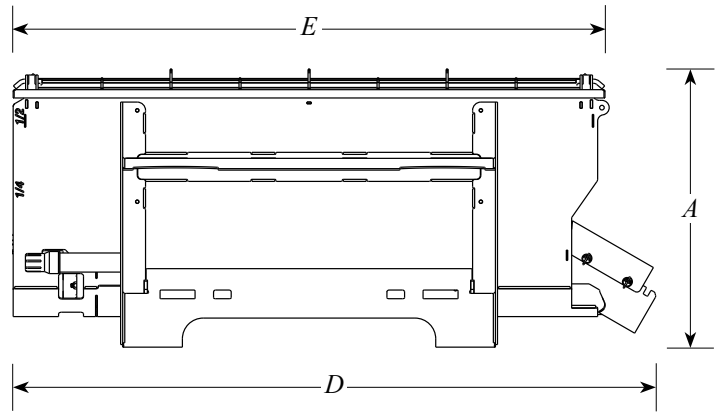
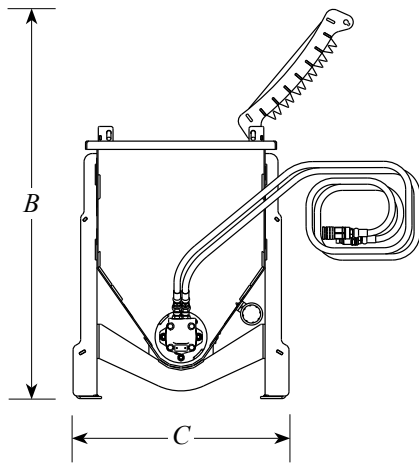

Operator's Manual
Direction Terminology

Front

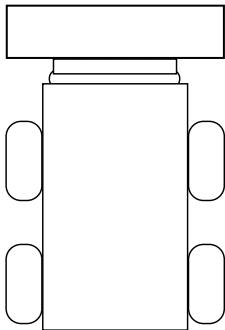

Left

Right

Rear

MAC Bucket	
Height, Grate Lowered (A)	33.5"
Height, Grate Open (B)	47"
Overall Width (C)	26"
Overall Length (D)	77.4"
Overall Hopper Length (E)	71.3"
Weight	Rubber Auger: 615 lb. Steel Auger: 620 lb.
Auger Diameter without Rubber	4"
Auger Diameter with Rubber	6.5"
Auger Diameter with Steel	6.12"
Center Column Diameter	1.32" O.D. .18" wall
Auger Length	60"
Flighting Spacing	4"
Capacity	1/2 yard (13.5 ft ³) Up to 3/4 yard (20 ft ³) with optional hopper extension
80-lb. Bags Concrete Mix	Approx. 18 (1/2 yd) Approx. 25 (3/4 yd)
Dispense Rate	28 seconds @ 24 GPM
Hydraulic Requirements	Up to 24 GPM Up to 3,500 PSI
Mounting Options	Skid-Steer Quick Attach

Hydraulic Requirements

Filtration Requirements:

- A filter of, at least, 10 micron filtration is required.

NOTE

The life of the hydraulic motor is almost entirely dependent upon cleanliness of the oil. Instructions in your vehicle operator's manual regarding filter and oil changes should be carefully followed. Even small amounts of dirt in the hydraulic oil can cause premature motor failure that is not covered by warranty.

Pressure and Flow Requirements:

- The MAC Bucket is designed to operate up to 24 GPM and up to 3,500 PSI.

Hydraulic Fluid Selection Requirements:

- Premium grade petroleum-based fluids will provide the best performance.
- Fluids that contain anti-wear agents, rust inhibitors, anti-foaming agents, and oxidation inhibitors are recommended.
- The viscosity of the fluid should never fall below 70 SUS (13 cST). The best viscosity range for the MAC Bucket is 100-200 SUS (20-43 cST).

Assembly & Installation

⚠ WARNING

Personal protection equipment including hard hat, safety glasses, safety shoes, gloves, and hearing protection are recommended during assembly, installation, operation, maintenance, service, removal, or movement of the attachment.

Prepare the Vehicle

Read and understand the manual for your vehicle before assembling or installing the MAC Bucket. The vehicle must be equipped with auxiliary hydraulics and a skid-steer quick attach mount. The use of the MAC Bucket may require the addition of counterweights to ensure the combined weight of the attachment and load does not exceed the rated capacity of your vehicle.

⚠ WARNING

Do not exceed the vehicle's rated operating load. If necessary, use sufficient counterweights.

Recommended Tools

- 9/16" wrench
- Metal snips

STEP 1: Using a 9/16" wrench and metal snips, remove the bolts securing the MAC Bucket to pallet, banding, and any other packaging materials.

STEP 2: Open the safety grate to gain access to the inside of the hopper. (The hinge pins on the opposite side should remain engaged to serve as a hinge point.)

A: Turn pins upward.

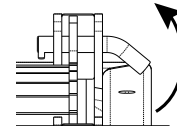

B: Pull pins.

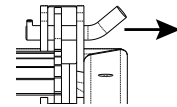

C: Turn pins downward.

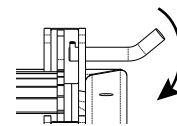

D: Open safety grate

STEP 3: Remove the chutes from inside the MAC Bucket.

STEP 4: Close and secure the safety grate.

⚠ DANGER

Do not operate MAC Bucket without safety grate in place and securely latched.

STEP 5: Park the vehicle on level ground, and install the MAC Bucket by following your vehicle operator's manual for installing an attachment.

⚠ WARNING

The MAC Bucket must be securely latched to the vehicle. Ensure both locking handles are in the locked position with pins fully seated. An improperly latched MAC Bucket can fall without warning.

Assembly & Installation

(continued)

⚠ WARNING

Keep hands, feet, hair, jewelry, and clothing away from all moving and/or rotating parts.

Assembly & Installation

Hopper Extension

⚠ WARNING

Personal protection equipment including hard hat, safety glasses, safety shoes, gloves, and hearing protection are recommended during assembly, installation, operation, maintenance, service, removal, or movement of the attachment.

STEP 6: Connect the hydraulic hoses to the vehicle's auxiliary hydraulics. Test the vehicle to make sure you have enough hose length to perform the full range of the loader arms' operating heights.

⚠ WARNING

Before connecting or disconnecting hydraulic lines or fittings, be sure to relieve all pressure by cycling all hydraulic controls after shutdown. Remember hydraulic systems are under pressure whenever the engine is running and may hold pressure after shutdown.

NOTE Ensure quick couplers are clean prior to connection.

NOTE Hose routing is the responsibility of the operator. Pinched and/or stretched hoses are not covered under the warranty.

STEP 7: Engage the vehicle's auxiliary hydraulics to make sure the MAC Bucket auger freely rotates forward and reverse.

STEP 8: Check the hydraulic system for leaks.

⚠ WARNING

Never check pressurized system for leaks with your bare hand. Wear proper hand and eye protection and use wood or cardboard when searching for suspected leaks. Oil escaping from pinhole leaks under pressure can penetrate skin and create a serious medical emergency. If any fluid is injected into the skin, gangrene, blood poisoning, even death may result. Obtain medical attention immediately.

Recommended Tools & Materials

- 1/2" wrench
- 1/2" socket
- Ratchet
- Vise grips
- Hammer
- Caulk gun
- General purpose silicone caulk

STEP 1: Park the vehicle on level ground, and rest the MAC Bucket on a solid, level surface.

STEP 2: Shut off the vehicle, and relieve all hydraulic pressure.

STEP 3: Remove packing material from the hopper extension.

STEP 4: Disengage the four (4) hinge pins, and remove the safety grate:

A: Turn pins upward.

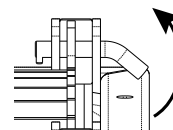

B: Pull pins.

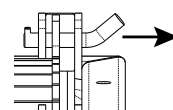

Assembly & Installation

Hopper Extension (continued)

⚠ CAUTION

Always use two people to handle heavy, unwieldy components during assembly, installation, maintenance, service, removal, or movement of the attachment.

C: Turn pins downward.

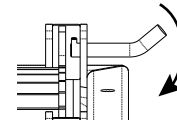

D: Remove safety grate.

STEP 5: Relocate the safety grate atop the hopper extension, and secure with the hopper extension hinge pins.

⚠ DANGER

Do not operate MAC Bucket without safety grate in place and securely latched.

STEP 6: Using a pair of vise grips and a hammer, remove the roll pins from all four (4) MAC Bucket hinge pins. Remove the hinge pins and discard.

STEP 7: Clean the top flange of the MAC Bucket.

STEP 8: Run a small bead of silicone caulk on the top flange of the MAC Bucket to create a watertight seal between the MAC Bucket and the hopper extension.

STEP 9: With the help of a second person, position the hopper extension onto the MAC Bucket.

STEP 10: Using the hardware provided, install the bolts, washers, and nuts. Leave hand-tight until all 16 bolts are installed.

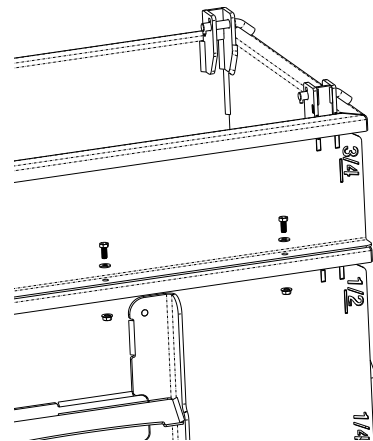

STEP 11: Using a 1/2" wrench and ratchet with a 1/2" socket, tighten all 16 bolts and nuts.

Operation

Dispense

! DANGER

The MAC Bucket is designed to be operated from the vehicle operator station. Keep bystanders away from the work area. Do not operate with another person in contact with the MAC Bucket.

! WARNING

Personal protection equipment including hard hat, safety glasses, safety shoes, gloves, and hearing protection are recommended during assembly, installation, operation, maintenance, service, removal, or movement of the attachment.

! WARNING

Safe operation of equipment requires the operator's full attention. Avoid distractions such as radio headphones, cell phones, etc. while operating.

! WARNING

Keep hands, feet, hair, jewelry, and clothing away from all moving and/or rotating parts.

! DANGER

Do not use the MAC Bucket as a work platform.

! DANGER

Stay away from power lines when transporting, raising, or operating the attachment. Electrocution can occur without direct contact.

! WARNING

Before you operate the attachment, check over pins and connections to be sure all are securely in place. Make sure the MAC Bucket is securely latched to the vehicle. Make sure the safety grate is properly installed.

STEP 1: Ensure the MAC Bucket is properly attached and chutes are removed.

STEP 2: Add material(s) to the hopper.

! WARNING

Do not exceed the vehicle's rated operating load. If necessary, use sufficient counterweights.

! DANGER

Do not operate MAC Bucket without safety grate in place and securely latched.

STEP 3: Position the vehicle and, if necessary, attach chute(s) to reach the desired dispensing location.

NOTE

If length of additional chutes exceeds eight (8) ft., then additional support must be added.

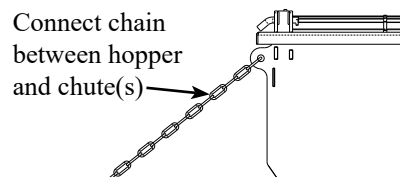

! DANGER

For operator safety, always keep the load in front of the vehicle. Load should never be tilted toward or positioned over the operator.

! WARNING

Carry the load low. A heavy load can cause instability of the vehicle. Use extreme care during travel. Slow down on turns and watch out for bumps. Use all safety devices, including a seat belt, as recommended in the vehicle operator's manual.

Operation

Dispense
(continued)

DANGER

Do not allow riders on the equipment at any time. There is no safe place for any riders.

WARNING

Never place yourself between the vehicle and the attachment.

Operation

Concrete Mixing &
Dispensing

DANGER

The MAC Bucket is designed to be operated from the vehicle operator station. Keep bystanders away from the work area. Do not operate with another person in contact with the MAC Bucket.

WARNING

Exposure to silica dust and other dust hazards can cause serious or fatal respiratory disease. Use appropriate respiratory protection.

STEP 4: Run the auger in the forward direction to dispense the material(s).

DANGER

Do not operate with another person in contact with the MAC Bucket.

Never reach into the discharge end of the auger.

NOTE

If dispensing and the auger locks up, material may be lodged between the auger and the side of the hopper. Run the auger in the opposite direction to attempt to remove the bind. If this is unsuccessful, some material(s) may need to be removed. Over a clear, designated area, lift the hopper and tilt it forward in increments, testing the auger until the auger breaks free and begins moving material again.

STEP 5: Shut off the vehicle's auxiliary hydraulics when dispensing is complete.

DANGER

Stay away from power lines when transporting, raising, or operating the attachment. Electrocution can occur without direct contact.

WARNING

Before you operate the attachment, check over pins and connections to be sure all are securely in place. Make sure the MAC Bucket is securely latched to the vehicle. Make sure the safety grate is properly installed.

STEP 1: Ensure the MAC Bucket is properly attached. Add dry material(s) to the dispensing end of the hopper and liquid to the motor end.

NOTE

Use the safety grate to break open bags by tossing a bag onto the bag breakers and rocking the bag back and forth until it splits, dumping material(s) into the hopper.

DANGER

Do not operate the MAC Bucket without safety grate in place and securely latched.

STEP 2: Run the auger in reverse to bring the dry material(s) to the liquid.

STEP 3: Add more dry material(s) and liquid to get the volume and mixture required.

NOTE

If mixing and the auger locks up, material may be lodged between the auger and the side of the hopper. Momentarily run the auger in the opposite direction to attempt to remove the bind.

NOTE

Motor stalling could occur if the mixture is too dry.

Operation

Concrete Mixing &
Dispensing
(continued)

! WARNING

Personal protection equipment including hard hat, safety glasses, safety shoes, gloves, and hearing protection are recommended during assembly, installation, operation, maintenance, service, removal, or movement of the attachment.

! WARNING

Safe operation of equipment requires the operator's full attention. Avoid distractions such as radio headphones, cell phones, etc. while operating.

! WARNING

Keep hands, feet, hair, jewelry, and clothing away from all moving and/or rotating parts.

! DANGER

Do not use the MAC Bucket as a work platform.

! DANGER

Do not allow riders on the equipment at any time. There is no safe place for any riders.

! WARNING

Do not exceed the vehicle's rated operating load. If necessary, use sufficient counterweights.

NOTE

If the mixture becomes too dry, it may be necessary to shovel material from the sides and corners of the hopper. Follow these steps to shovel material(s):

! DANGER

Do not operate with another person in contact with the MAC Bucket.

Never reach into discharge end of auger.

! DANGER

Keep clear of auger while in operation. Never position the material by hand or with any tool when the auger is rotating.

- 1: If material begins to build up on the sides of the hopper, stop mixing.
- 2: Rest the MAC Bucket on a solid, level surface, and deactivate all hydraulics.
- 3: Open the safety grate to gain access to the inside of the hopper. (The hinge pins on the opposite side should remain engaged to serve as a hinge point.)

A: Turn pins upward.

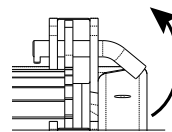

B: Pull pins.

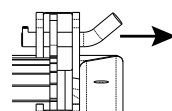

C: Turn pins downward.

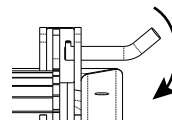

D: Lift the grate until it rests in the open position.

! WARNING

Ensure safety grate is properly resting in the open position.

- 4: Shovel the material away from the sides and toward the center of the hopper.
- 5: Close and secure the safety grate.

Operation

Concrete Mixing &
Dispensing
(continued)

⚠ WARNING

Never place yourself between the vehicle and the attachment.

⚠ DANGER

Do not operate MAC Bucket without the safety grate in place and securely latched.

STEP 4: When mixing is complete, position the vehicle and, if necessary, attach additional chute(s) to reach the desired dispensing location.

NOTE

If length of additional chutes exceeds eight (8) ft., then additional support must be added.

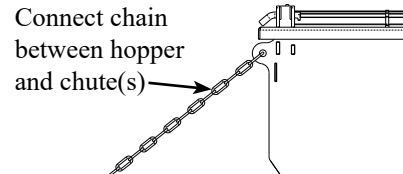

⚠ DANGER

For operator safety, always keep the load in front of the vehicle. Load should never be tilted toward or positioned over the operator.

⚠ WARNING

Carry the load low. A heavy load can cause instability of the vehicle. Use extreme care during travel. Slow down on turns and watch out for bumps. Use all safety devices, including a seat belt, as recommended in the vehicle operator's manual.

STEP 5: Run the auger in the forward direction to dispense the material(s).

⚠ DANGER

Do not operate with another person in contact with the MAC Bucket.

Never reach into the discharge end of the auger.

NOTE

If dispensing and the auger locks up, material may be lodged between the auger and the side of the hopper. Run the auger in the opposite direction to attempt to remove the bind. If this is unsuccessful, some material(s) may need to be removed. Over a clear, designated area, lift the hopper and tilt it forward in increments, testing the auger until the auger breaks free and begins moving material again.

STEP 6: Shut off the vehicle's auxiliary hydraulics when dispensing is complete.

Cleaning

DANGER

Never attempt adjustments, service, or repairs while the equipment is in operation.

DANGER

Never allow anyone under the attachment at any time.

WARNING

Keep hands, feet, hair, jewelry, and clothing away from all moving and/or rotating parts.

WARNING

Personal protection equipment including hard hat, safety glasses, safety shoes, gloves, and hearing protection are recommended during assembly, installation, operation, maintenance, service, removal, or movement of the attachment.

WARNING

Safe operation of equipment requires the operator's full attention. Avoid distractions such as radio headphones, cell phones, etc. while operating.

Depending upon the material dispensed, it may be necessary to add a cleaner or appropriate releasing agent to aid in cleaning the MAC Bucket.

STEP 1: Run the MAC Bucket until all of the material is dispensed from the bucket.

STEP 2: A second person, standing a safe distance away from the MAC Bucket, should add water to the dispensing end of the hopper while the operator runs the auger in reverse, agitating the water and cleaning the hopper.

DANGER

Do not operate with another person in contact with the MAC Bucket.

Never reach into discharge end of auger.

STEP 3: Run the auger in the forward direction to dispense the watery mixture.

NOTE

If necessary, raise the hopper and tilt it forward to rinse out any remaining material.

NOTE

If necessary, to clean build-up in hard-to-reach areas, open the safety grate as previously described in Operation. Once the build-up is removed, close and securely latch the safety grate.

DANGER

Do not operate the MAC Bucket without safety grate in place and securely latched.

STEP 4: Level the MAC Bucket, and lower it to the ground.

STEP 5: Shut off the vehicle engine, relieve all hydraulic pressure, and remove the vehicle key before leaving the vehicle operator station.

STEP 6: Remove the two (2) klik pins and lift the discharge rubber flap at the discharge end of the bucket. Clean it with water. Make sure there is not any material between the auger and the discharge tube.

STEP 7: Close the discharge rubber flap, and secure it with the two (2) klik pins.

STEP 8: Depending upon the material dispensed, coat the hopper with a rust protectant, concrete releasing agent, or asphalt releasing agent.

NOTE

Do not allow material(s) to dry or water to freeze in the hopper. This will cause damage to the auger and the hopper.

Removal & Storage

DANGER

Never allow anyone under the attachment at any time.

WARNING

Personal protection equipment including hard hat, safety glasses, safety shoes, gloves, and hearing protection are recommended during assembly, installation, operation, maintenance, service, removal, or movement of the attachment.

CAUTION

Always use two people to handle heavy, unwieldy components during assembly, installation, maintenance, service, removal, or movement of the attachment.

Before storage, the MAC Bucket should be thoroughly cleaned (refer to *Cleaning*). Make sure the hydraulic system is properly sealed against contaminants entering the unit. Always store the MAC Bucket in a dry, covered location.

STEP 1: Lower the MAC Bucket onto a flat, level surface in an area where children do not play.

STEP 2: Disconnect the hydraulic hoses from the vehicle's auxiliary hydraulics.

WARNING

Before connecting or disconnecting hydraulic lines or fittings, be sure to relieve all pressure by cycling all hydraulic controls after shutdown. Remember hydraulic systems are under pressure whenever the engine is running and may hold pressure after shutdown.

NOTE

Connect the quick couplers together to prevent contaminants from entering the MAC Bucket's hydraulic system.

STEP 3: Follow your vehicle operator's manual for removing an attachment. Securely block and support the MAC Bucket.

STEP 4: Tighten any loose nuts, bolts, and hydraulic components.

STEP 5: Replace any damaged or missing safety signs.

STEP 6: Lubricate the grease zerk.

Troubleshooting

Problem	Possible Cause	Solution
Auger does not rotate	Air in hydraulic system	Actuate hydraulics until auger has made one full rotation in forward and in reverse.
	Sheared key or roll pin	Remove auger and replace damaged component.
	Hydraulic hose pinched or obstructed	Fix pinched hose or remove obstruction.
	Leaking or failed hydraulic hose	Replace hydraulics hose.
	Quick couplers not engaged	Check quick coupler connects to vehicle.
	Vehicle auxiliary hydraulics not activated	Activate auxiliary hydraulics.
	Vehicle low on hydraulic oil	Add hydraulic oil to vehicle.
	Motor damaged	Contact Danuser.
	Auger locked up or compacted	Refer to <i>Concrete Mixing & Dispensing</i> .
Poor auger performance	Low flow	Check with flow meter. If low, investigate cause.
	Hydraulic hose restrictions	Clear hydraulic hose.
	Dirty oil or filter	Change oil and filter according to vehicle manufacturer's recommendation.
	Low hydraulic system pressure (PSI)	Check with pressure gauge. If low, investigate cause.
	Material build-up in discharge tube	With vehicle disconnected, lift discharge rubber flap to check for build-up within tube. Clean out as necessary.
	Material(s) too large	Reduce material size.
Leaking hopper	Material dispensing too thin	Run auger continuously in reverse, or thicken material.
	Worn motor seal	Replace motor seal.
	Damaged hopper	Contact Danuser.
Safety grate hinge pins hard to retract	Hinge pin not oriented upward	Ensure roll pin faces upward and aligns with slot in ears.
	Safety grate obstructed	Ensure no material is jammed between safety grate and ears.
Safety grate hard to open	Hinge pin not oriented downward	Ensure roll pin faces downward so hinge pin clears hole in safety grate.
	Safety grate obstructed	Ensure no material is jammed between safety grate and ears.
	Hinge pins not fully retracted	Check hinge pins fully clear edges of safety grate.
	Hinge pins not fully engaged	Check opposite side pivot point hinge pins are fully engaged.

For additional assistance, please call your dealer or contact Danuser direct:

*Tel: (573) 642-2246
E-mail: sales@danuser.com*

Maintenance & Lubrication

⚠ DANGER

Never attempt adjustments, service, or repairs while the equipment is in operation.

⚠ DANGER

Never allow anyone under the attachment at any time.

⚠ DANGER

Never work under equipment supported by hydraulics. Even with the vehicle shut off, equipment can suddenly drop if controls are actuated or if hydraulic lines burst.

⚠ WARNING

Personal protection equipment including hard hat, safety glasses, safety shoes, gloves, and hearing protection are recommended during assembly, installation, operation, maintenance, service, removal, or movement of the attachment.

Proper servicing and maintenance are key to the long life of any attachment. Careful inspection and routine maintenance help avoid costly downtime and repair. Do not use the MAC Bucket with any damaged parts.

⚠ WARNING

Never check pressurized system for leaks with your bare hand. Wear proper hand and eye protection and use wood or cardboard when searching for suspected leaks. Oil escaping from pinhole leaks under pressure can penetrate skin and create a serious medical emergency. If any fluid is injected into the skin, gangrene, blood poisoning, even death may result. Obtain medical attention immediately.

⚠ WARNING

Do not modify the attachment. Modifications may weaken the integrity of the attachment and may impair the safety, function, life, and performance of the MAC Bucket.

⚠ CAUTION

When making repairs or servicing the MAC Bucket, use only parts that meet the original equipment manufacturer's standards and requirements.

Maintenance	Interval
Inspect the attachment for any damage, worn parts, or cracked welds. Repair or replace as necessary.	Before each use
Check for damaged or missing safety signs. Replace as necessary.	Before each use
Check all fasteners. Ensure they are tight and secure. (See <i>Torque Values Chart</i> .) Replace as necessary.	Daily
Check all hydraulic components for leaks or wear. Repair or replace as necessary.	Daily

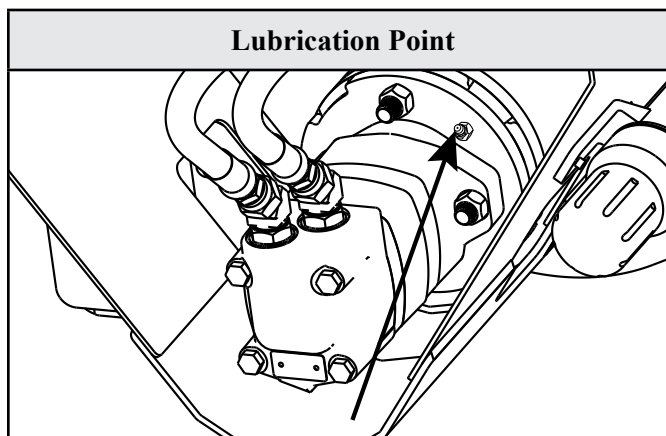

Motor Mounting Plate - 1 Zerk
Add multi-purpose grease until grease emerges

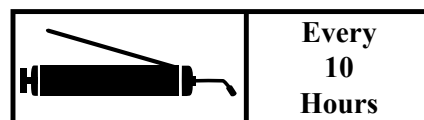

Service

Replacing Rubber Auger Flighting

⚠ DANGER

Never attempt adjustments, service, or repairs while the equipment is in operation.

⚠ DANGER

Never allow anyone under the attachment at any time.

⚠ DANGER

Never work under equipment supported by hydraulics. Even with the vehicle shut off, equipment can suddenly drop if controls are actuated or if hydraulic lines burst.

⚠ WARNING

Personal protection equipment including hard hat, safety glasses, safety shoes, gloves, and hearing protection are recommended during assembly, installation, operation, maintenance, service, removal, or movement of the attachment.

⚠ CAUTION

Always use two people to handle heavy, unwieldy components during assembly, installation, maintenance, service, removal, or movement of the attachment.

Recommended Tools

- 5/16" punch
- Hammer
- 7/16" wrench
- Dead-blow hammer or mallet

If MAC Bucket is equipped with rubber flighted auger, the discs should only be replaced when performance has been reduced or material leaks out of the discharge end when the auger is not rotating. It is not necessary to replace all of the rubber flights at once. Replace only the flights that have extensive wear (usually the ones at the discharge end of the auger).

NOTE

Use genuine Danuser replacement parts only. Substitute parts may not meet standards required for safe, dependable operation.

STEP 1: Lower the MAC Bucket onto a flat, level surface.

STEP 2: Shut off the vehicle engine, relieve all hydraulic pressure, and remove the vehicle key before leaving the vehicle operator station.

STEP 3: Open the safety grate. Refer to *Operation*.

STEP 4: Using a 5/16" punch and hammer, remove the roll pin in the auger collar.

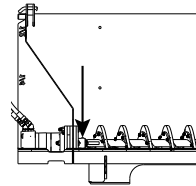

STEP 5: Slide the auger away from the motor until the collar clears the shaft.

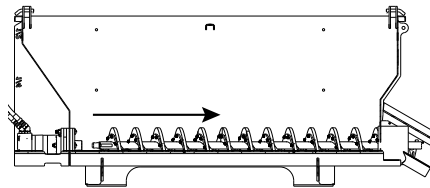

STEP 6: Pull up and slide the auger toward the motor end of the bucket until the auger is free of the discharge tube.

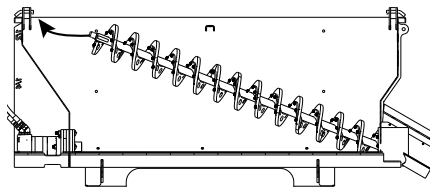

STEP 7: Place the auger on a secure work platform. Use a hammer and chisel to remove the lock nuts from the flights to be replaced.

STEP 8: Using the supplied hardware and a 7/16" wrench, replace worn rubber flights. The first seven (7) rubber flights have the wear face toward the motor end of the bucket. The remaining flights have the wear face toward the discharge end of the bucket.

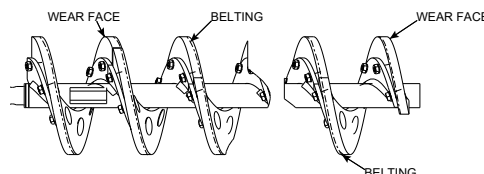

Torque Values Chart

Torque Values Chart																	
Bolt Size (inches)	Bolt Head Identification								Bolt Size (Metric)	Bolt Head Identification							
	Grade 2		Grade 5		Grade 8		ASTM A574			5.8	Class 8.8		Class 10.9		Class 12.9		
in-tpi	Nm	ft.-lb.	Nm	ft.-lb.	Nm	ft.-lb.	Nm	ft.-lb.	mm x pitch	Nm	ft.-lb.	Nm	ft.-lb.	Nm	ft.-lb.	Nm	ft.-lb.
1/4"-20	7.4	5.6	11	8	16	12	19	14	M5 x 0.8	4	3	6	5	9	7	11	8
1/4"-28	8.5	6	13	10	18	14	22	16	M6 x 1	7	5	11	8	15	11	18	13
5/16"-18	15	11	24	17	33	25	39	29	M8 x 1.25	17	12	26	19	36	27	42	31
5/16"-24	17	13	26	19	37	27	43	32	M8 x 1	18	13	28	21	39	29	46	34
3/8"-16	27	20	42	31	59	44	69	51	M10 x 1.5	33	24	52	39	72	53	84	62
3/8"-24	31	22	47	35	67	49	79	58	M10 x 0.75	39	29	61	45	85	62	98	72
7/16"-14	43	32	67	49	95	70	110	81	M12 x 1.75	58	42	91	67	125	93	148	109
7/16"-20	49	36	75	55	105	78	123	91	M12 x 1.5	60	44	95	70	130	97	153	113
1/2"-13	66	49	105	76	145	105	168	124	M12 x 1	90	66	105	77	145	105	167	123
1/2"-20	75	55	115	85	165	120	190	140	M14 x 2	92	68	145	105	200	150	235	173
9/16"-12	95	70	150	110	210	155	235	173	M14 x 1.5	99	73	155	115	215	160	254	187
9/16"-18	105	79	165	120	235	170	262	193	M16 x 2	145	105	225	165	315	230	365	269
5/8"-11	130	97	205	150	285	210	323	238	M16 x 1.5	155	115	240	180	335	245	388	286
5/8"-18	150	110	230	170	325	240	366	270	M18 x 2.5	195	145	310	230	405	300	504	372
3/4"-10	235	170	360	265	510	375	574	423	M18 x 1.5	220	165	350	260	485	355	561	414
3/4"-16	260	190	405	295	570	420	640	472	M20 x 2.5	280	205	440	325	610	450	712	525
7/8"-9	225	165	585	430	820	605	925	682	M20 x 1.5	310	230	650	480	900	665	1052	776
7/8"-14	250	185	640	475	905	670	1020	752	M24 x 3	480	355	760	560	1050	780	1231	908
1"-8	340	250	875	645	1230	910	1386	1022	M24 x 2	525	390	830	610	1150	845	1337	986
1"-12	370	275	955	705	1350	995	1555	1147	M30 x 3.5	960	705	1510	1120	2100	1550	2447	1805
1-1/8"-7	480	355	1080	795	1750	1290	1971	1454	M30 x 2	1060	785	1680	1240	2320	1710	2706	1996
1-1/8"-12	540	395	1210	890	1960	1440	2202	1624	M36 x 3.5	1730	1270	2650	1950	3660	2700	4272	3151
1-1/4"-7	680	500	1520	1120	2460	1820	2771	2044	M36 x 2	1880	1380	2960	2190	4100	3220	5095	3758
1-1/4"-12	750	555	1680	1240	2730	2010	3068	2263	KEY: in-tpi = nominal thread diameter in inches-threads per inch Nm = Newton-meter ft.-lb. = foot pounds mm x pitch = nominal thread diameter in millimeters by thread pitch								
1-3/8"-6	890	655	1990	1470	3230	2380	3638	2683									
1-3/8"-12	1010	745	2270	1670	3680	2710	4143	3056									
1-1/2"-6	1180	870	2640	1950	4290	3160	4823	3557									
1-1/2"-12	1330	980	2970	2190	4820	3560	5426	4002									

Torque tolerance +0%, -15% of torque values. Unless otherwise specified, use torque values listed above.

Parts

⚠ CALIFORNIA WARNING

This product can expose you to chemicals including lead, which are known to the State of California to cause cancer and birth defects or other reproductive harm. For more information go to www.P65Warnings.ca.gov.

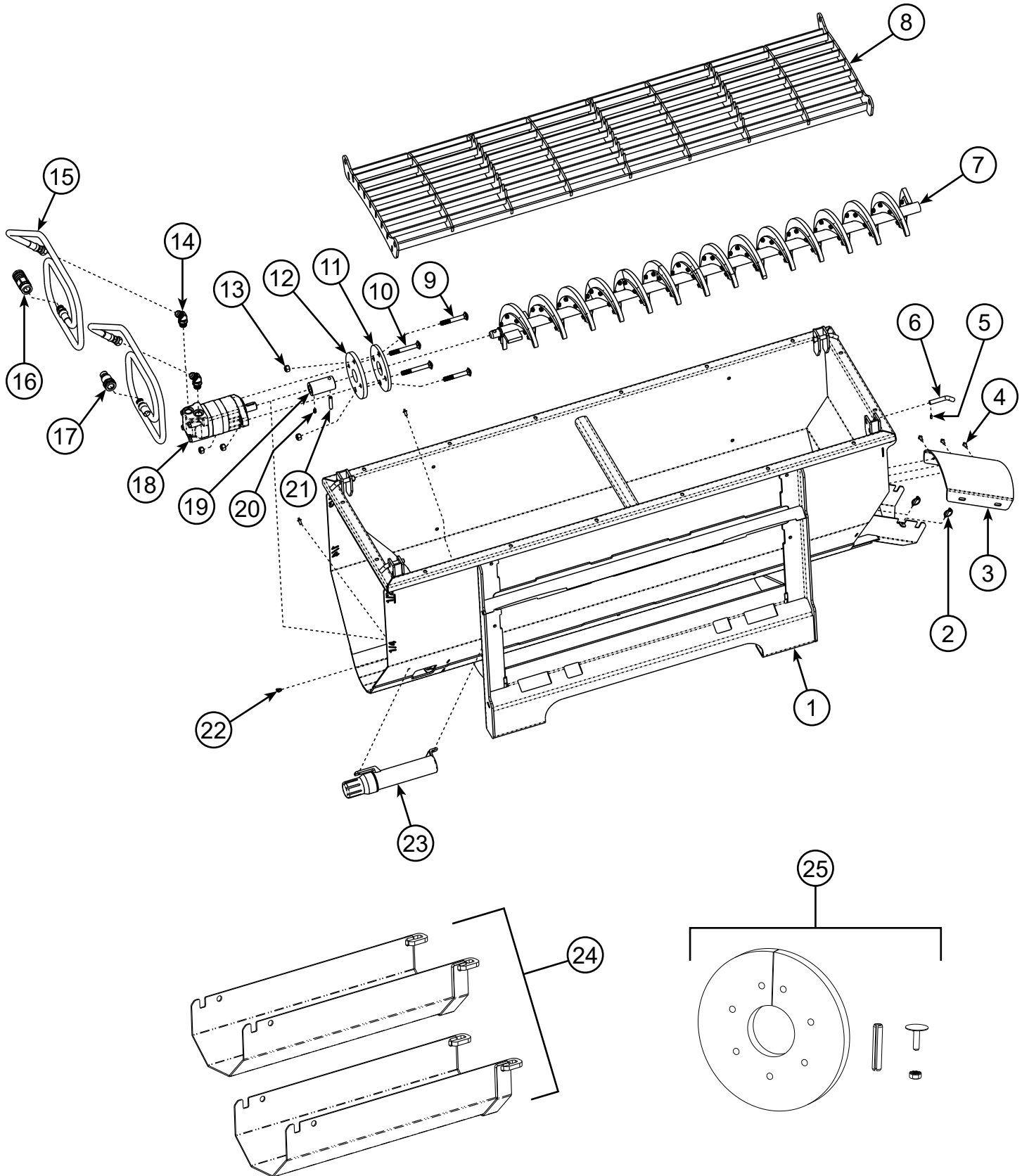

Parts

(continued)

REF. NO.	PART NO.	DESCRIPTION	QTY.
1	230410S	Hopper - Service	1
2	7637	Klik Pin Assembly	2
3	230443	Discharge Rubber Flap	1
4	176033	Drive Rivet	5
5	176010	Roll Pin (3/16" x 1/2")	4
6	170073	Hinge Pin	4
7	11047	Rubber Auger Assembly	1
	11063	Steel Auger Assembly	1
8	230450	Safety Grate	1
9	246005	Carriage Bolt (1/2"-13 x 3.5", Gr. 5)	2
10	246004	Carriage Bolt (1/2"-13 x 4", Gr. 5)	2
11	230441	Seal Retaining Plate	1
12	230440	Seal	1
13	10125	Toplock Nut (1/2"-13)	4
14	10040	Adapter, 45° (#10 JIC M to #10 ORB M)	2
15	246006	1/2" Hose Assembly (#10 JIC F to #10 ORB M)	2
16	10049	Female Coupler (1/2" flush-face, ISO 16028)	1
17	10048	Male Coupler (1/2" flush-face, ISO 16028)	1
18	246008	Hydraulic Motor	1
19	230442	Hub	1
20	246002	Set Screw (5/16"-18 x 1/2")	1
21	11038	Roll Pin (3/8" x 2")	1
22	246029	Grease Fitting, 45°	1
23	21258	Operator's Manual Canister	1
24	11019	Chute - 24"	2
25	*11050	Rubber Flighted Auger Replacement Kit	

* Not included with base model.

This product can expose you to chemicals including lead, which are known to the State of California to cause cancer and birth defects or other reproductive harm. For more information go to www.P65Warnings.ca.gov.

Front-End Loader Hose Kit

PN 196056 - 1/2" hoses, 25' long, with 1/2" flush-face couplers (ISO 16028) on one end to connect to MAC Bucket hoses, and ISO 7241 Series A couplers (compatible with ISO 5675 Pioneer couplers) on the opposite end to connect to tractor rear remotes. Includes bolt-on/weld-on mounting bracket.

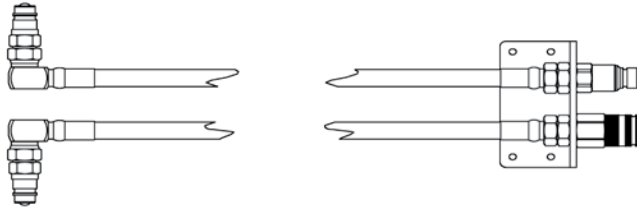

Hopper Extension

PN 230459 - Expands MAC Bucket capacity from 1/2 yard to 3/4 yard. Hardware included.

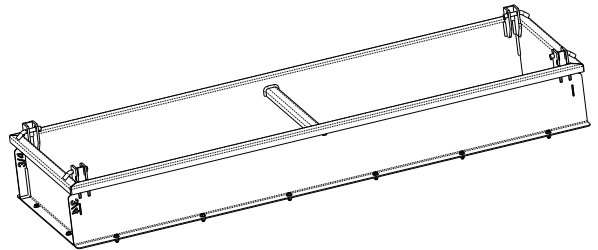

Chute - 24"

PN 11019 - Chute can be linked to extend length.

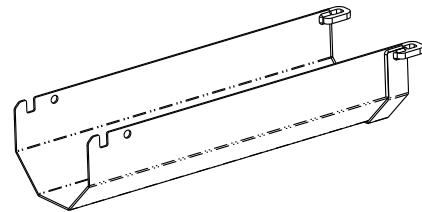

Auger Assembly

PN 11047 - Rubber Auger Assembly

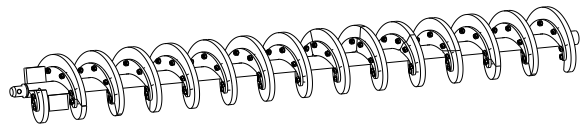

Auger Assembly

PN 11063 - Steel Auger Assembly

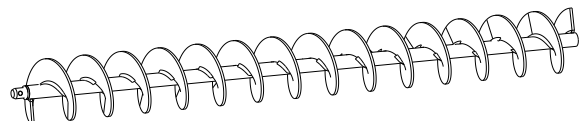

This page is intentionally blank.

LIMITED WARRANTY

Danuser Machine Company, LLC ("Danuser") warrants its products, under normal use and maintenance, to be free from defects in material and workmanship for period(s) specified below from the purchase date from an authorized Danuser Dealer. Start of the warranty period is determined by purchase date given on your returned WARRANTY REGISTRATION FORM. Proof of purchase may be required. This Limited Warranty is extended only to the original purchaser of Danuser products.

MAC Bucket - 1 Year

Wear Items Not Covered Under Warranty - Hydraulic Hoses, Seals, and Auger Flighting

1. During the applicable warranty period, Danuser, at its option, will repair or replace any part determined by Danuser to be defective. Such repair or replacement shall take place at Danuser's factory or a location designated by Danuser. Under no circumstances shall Danuser be obligated for the cost of any repair or replacement by anyone other than Danuser without its express written consent.
2. Parts may not be returned without written authorization from Danuser.
3. Some purchased components, including but not limited to hydraulic components, are subject to the inspection and warranty of the respective manufacturer. Thus, delays in a warranty determination can be expected while Danuser awaits their decision.
4. This warranty is void if any attempt is made to make field repairs to hydraulic components. To qualify for warranty inspection, the "failed" part(s) must be returned in its original "failed" condition.
5. To make a claim under this warranty, you may either contact your authorized Danuser Dealer or initiate a claim directly with Danuser. In either case, a Warranty Claim Form must be completed and written authorization from Danuser obtained prior to returning parts. All warranty claims must include detailed information regarding make and model of vehicle on which the Danuser product was mounted, hours of use, description of events that led up to the failure, and any other information helpful in reviewing the warranty claim. All warranty returns must be prepaid. Shipments arriving at our factory on a freight collect basis will be refused by our receiving department. The freight charge will be credited if the parts are determined by Danuser to be defective, and the associated freight costs in returning those parts will be prepaid by Danuser. NOTE: Hydraulic components must arrive with all ports sealed from dirt and moisture. If a hydraulic component arrives with open ports, the warranty is void and no inspection will be made.
6. Products or parts thereof, which, as determined by Danuser's examination, show wear from normal use, have been improperly operated, damaged by accident or negligence, field repaired, altered or modified are not considered defective in material and workmanship and are not covered by this warranty. This warranty does not apply to parts subject to normal wear ("Wear Items") or to damage caused by the failure to perform recommended maintenance or to replace worn parts. This warranty shall not obligate Danuser to bear any cost of labor for field repair, replacement, testing, or adjustment nor for damage caused by accident, abuse, misuse, or environmental elements.
7. Any parts or labor required to repair or replace parts not covered under this warranty will be charged to the customer. Parts repaired or replaced by Danuser are then covered by this warranty only for the remainder of the original warranty as if such parts were original parts.
8. Danuser reserves the right to change its specifications and designs at any time.

This warranty is exclusive and in lieu of all other express warranties, if any, including the implied warranties of merchantability and fitness for a particular purpose. It shall not extend beyond the duration of the expressed warranty provided herein and the remedy for violations of any implied warranty shall be limited to repair or replacement of the defective part pursuant to the terms contained herein. No employee, dealer, salesman, or representative is authorized to change this warranty in any way or grant any other warranty. Danuser shall not be liable for any consequential, incidental, or punitive damages, losses, or expenses, including those resulting from or caused by any defects.

Danuser Machine Company, LLC
500 E. 3rd St.
P.O. Box 368
Fulton, MO 65251

Tel: (573) 642-2246
E-mail: sales@danuser.com
Website: www.danuser.com